

3D SMART SENSORS FOR INLINE INSPECTION

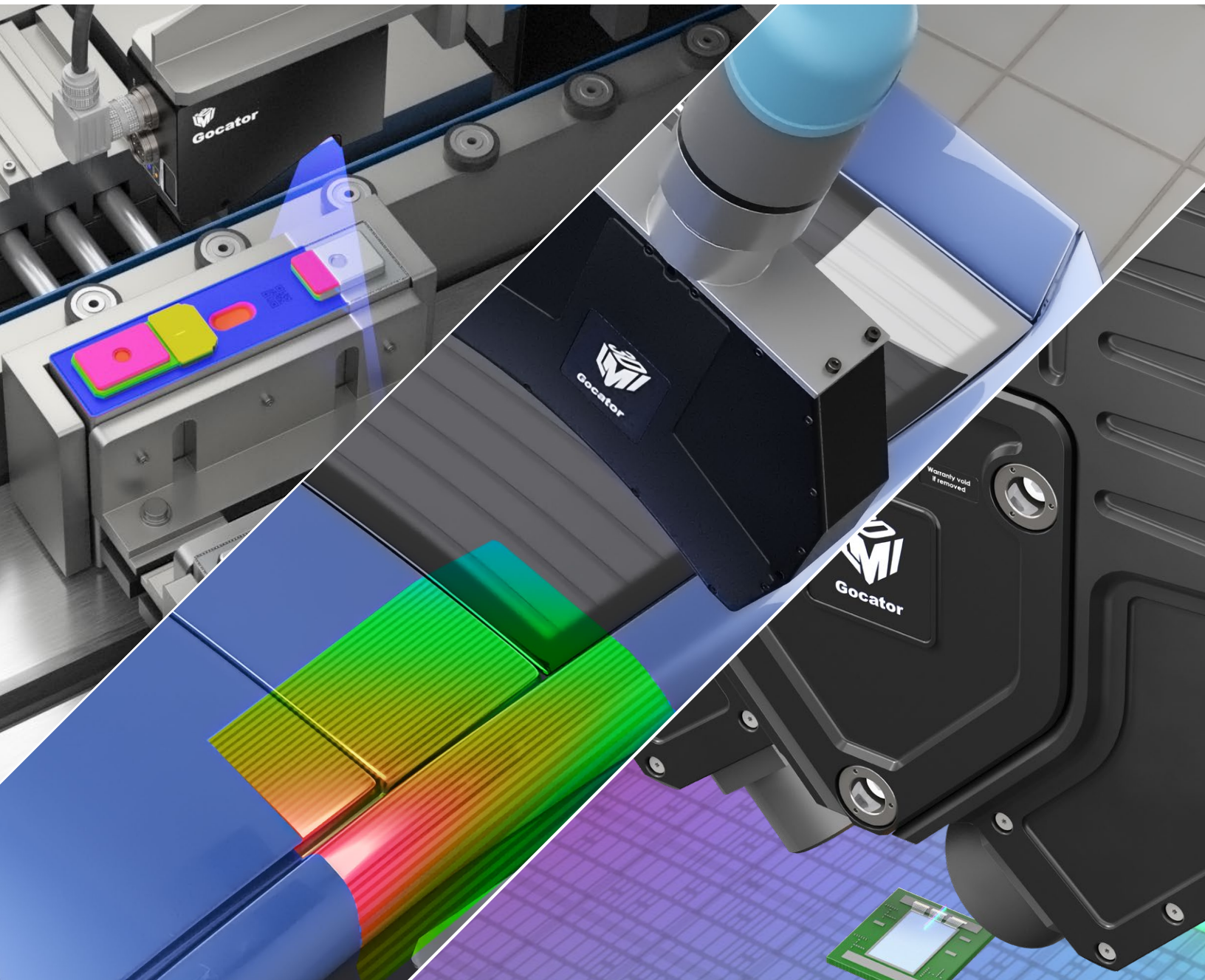

Trusted 3D Technologies for Inline Metrology-Grade Inspection.

Gocator®

LASER PROFILERS

Gocator Point and Line Profile Sensors inspect any **moving target** with height resolutions down to 1.1 μm , sampling speeds up to 32 kHz, and a suite of built-in 3D measurement tools and smart features to deliver a complete 3D inspection solution.



SNAPSHOT SENSORS

Gocator Stereo Snapshot Sensors generate 3D point clouds with a single scan trigger. These sensors offer built-in 3D measurement tools to inspect **any stationary target**, or automate assembly using robot guidance.

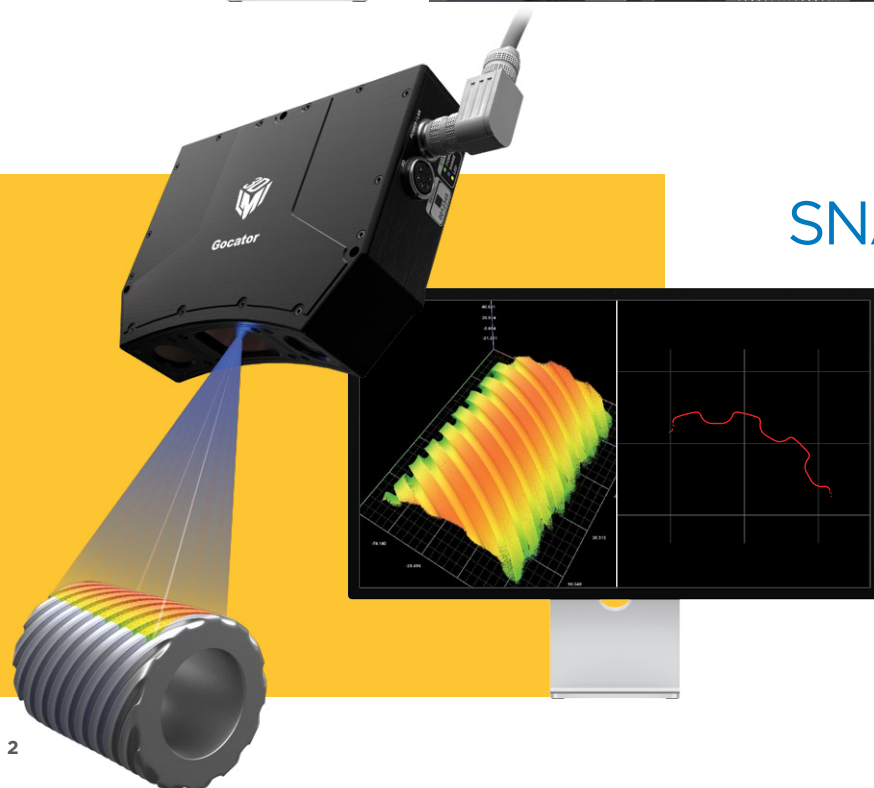

SMART 3D LINE CONFOCAL SENSORS

Gocator Line Confocal Sensors deliver high speed, wide coverage 2K line scanning with simultaneous generation of **3D topography**, **3D tomography**, and **2D intensity data**. This allows these sensors to scan practically any material type—including multi-layered, transparent/translucent, curved edge, and more.



SMART 3D COAXIAL LINE CONFOCAL SENSORS

The Gocator Coaxial Line Confocal sensors provide **high-speed**, **high-resolution**, versatile and **shadow-free** 3D inline inspection performance with outstanding angular range (Max Slope Angle up to +/- 85 degrees) for manufacturing applications in Semiconductor, Consumer Electronics, EV Battery, and many more.

WELCOME TO **FACTORYSMART**[®] INSPECTION

Gocator[®]

Gocator is a non-contact 3D scanning and inspection sensor ready to deploy into the factory to deliver 100% inspection of parts and assemblies in order to ensure product quality.

Easy to Use

Features such as a web-browser driven point-and-click environment for rapid configuration, built-in measurement tools and rich I/O for communicating results make it easy for factory technicians to get the results they need.

Low Latency with No External Controller Required

Real-time measurement capabilities minimize lag between data acquisition and decision outputs, which means factories can consistently meet their throughput targets.

Built-In Measurement Tools

Built-in tools provide a drag and drop environment with full 3D visualization, and allow users to set measurements based on the specific feature that needs to be inspected.

Customizable

Sensor customization allows users to develop and embed their own custom measurement tools directly into the firmware itself—with the same functionality and ease-of-use as built-in native tools.



3D IS OUR EXPERTISE

At LMI Technologies we work to advance quality and productivity with 3D sensor technology. Our award-winning, FactorySmart[®] sensors improve inline factory production by providing fast, accurate, reliable inspection solutions that leverage smart 3D technologies. Unlike contact-based measurement or 2D vision, our products remove complexity and dramatically reduce implementation cost while achieving repeatable, high-precision measurement.

TOTAL QUALITY CONTROL WITH SMART 3D

Gocator is used in all major inline manufacturing processes for quality control and improved factory production.

PART MANUFACTURING

Most parts from processes such as casting, machining, and injection molding are never inspected. Gocator provides 100% inline quality control to ensure every part meets key manufacturing tolerances.

COMPONENT ASSEMBLY

As parts come together to build product assemblies, how each part fits with another determines overall assembly quality. Gocator verifies proper adhesion, fastening, surface gap & flush and more.

FINISH AND PACKAGING

Finish and sealing is critical to product acceptance. Gocator ensures finished products meet strict quality standards, are packaged correctly, and are ready for shipment.

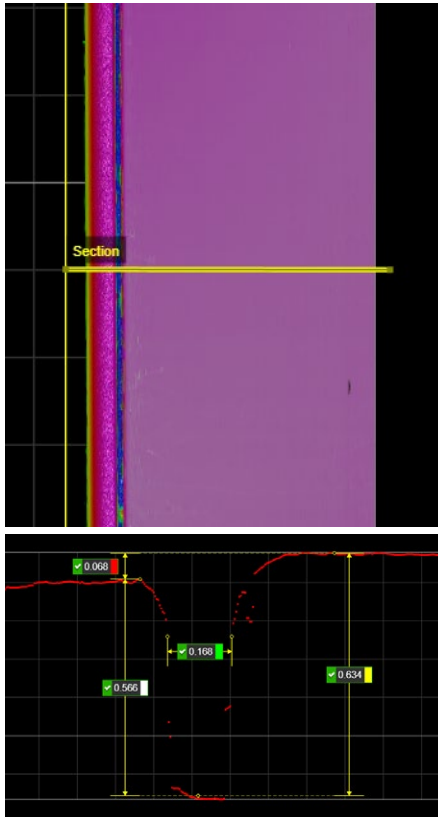

WHY SMART 3D?

2D vision alone cannot achieve 100% quality control, which is why you need to invest in a smart 3D solution.

- Volumetric measurement (X, Y, and Z-axis) provides shape and position related parameters—necessary for robot handling
- Contrast invariant, ideal for inspecting low contrast objects
- Immune to lighting variation and ambient light
- Higher repeatability due to integrated optics, lighting, and pre-calibration
- Simpler to build multi-sensor setups for large object inspection

PART MANUFACTURING INSPECTION



Stamping Inspection

Line profiler used to determine the final bend angle in a press brake

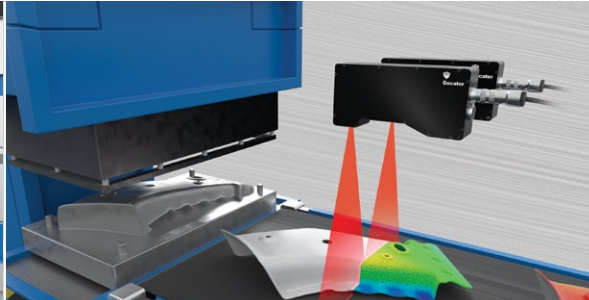

Two sensors in a wide configuration, combining profiles into a single surface scan

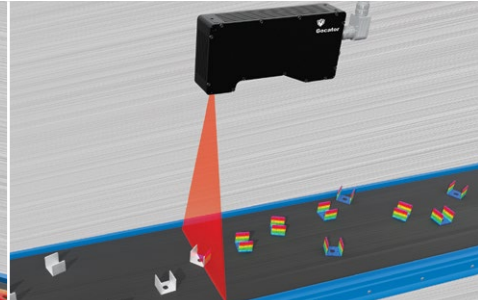

Scanning finished brackets to verify interior dimensions

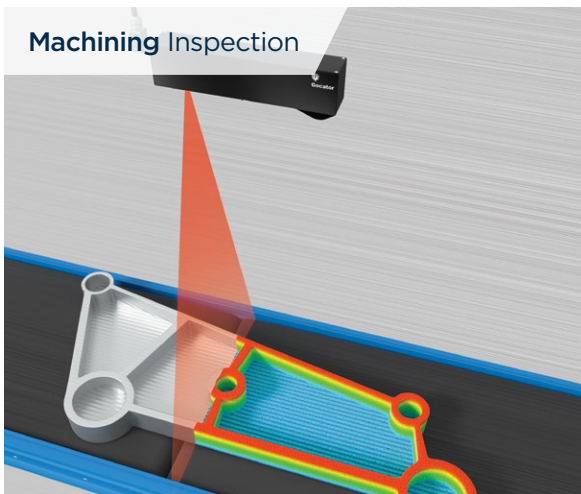

Machining Inspection

Finished CNC part scanned to verify depths and hole sizes within tolerance

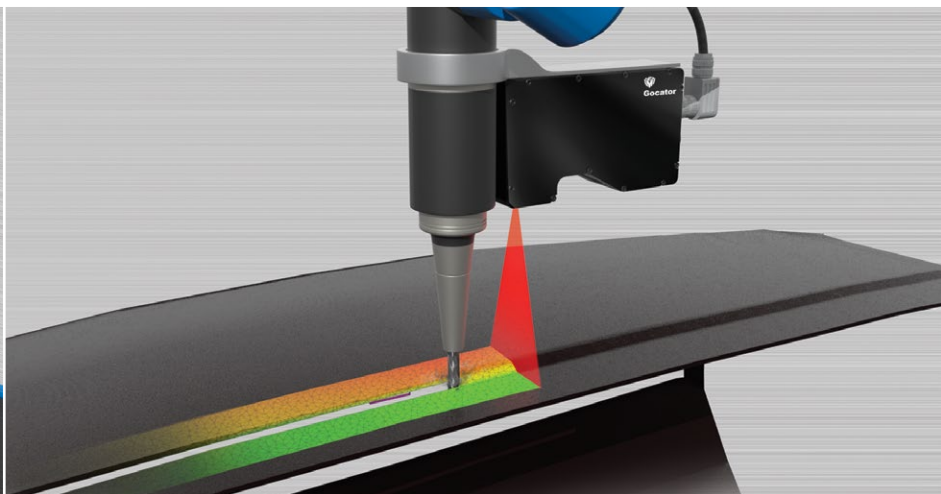

Vision-guidance for robotic CNC of an automotive dashboard



COMMON PROBLEM:
**PART SHAPE AND POSITION VARIATION
IN AN INLINE PROCESS**



FactorySmart® SOLUTION:
**ACHIEVE HIGH GAUGE REPEATABILITY AND
REPRODUCIBILITY (GRR) WITH ANCHORING AND
PART MATCHING**

- Built-in anchoring tracks the movement of parts within the sensor's field of view and corrects for variations in the height and position of parts.
- Part matching automatically performs realignment before applying Gocator's built-in measurement tools—eliminating the need to mechanically realign parts.

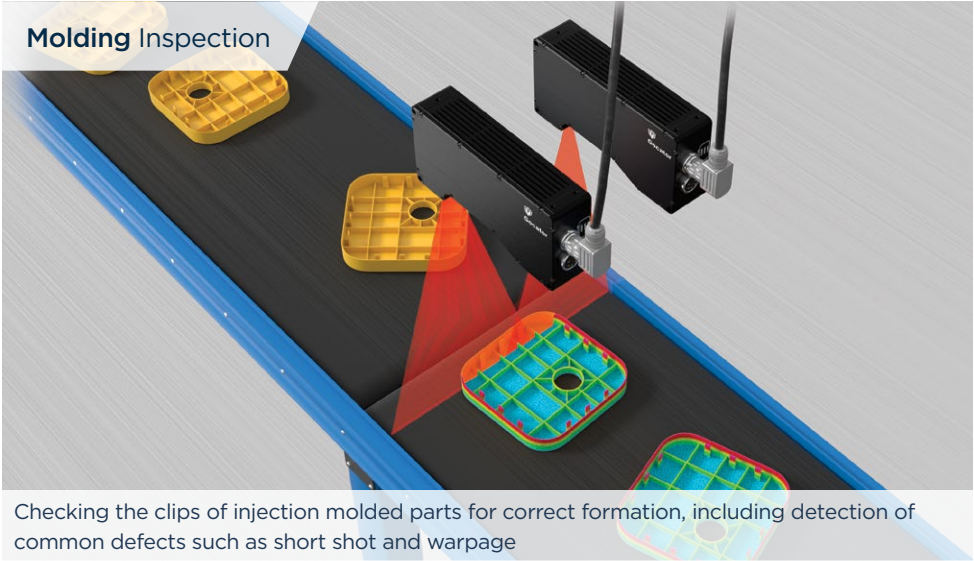

Molding Inspection

Checking the clips of injection molded parts for correct formation, including detection of common defects such as short shot and warpage

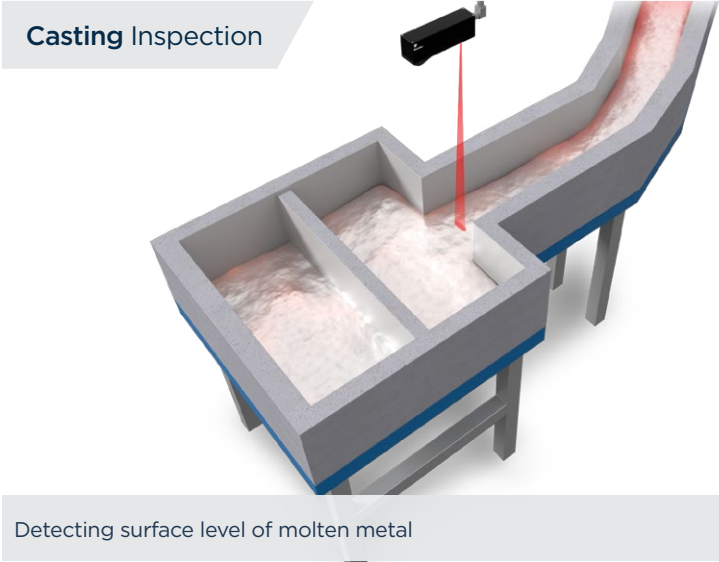

Casting Inspection

Detecting surface level of molten metal

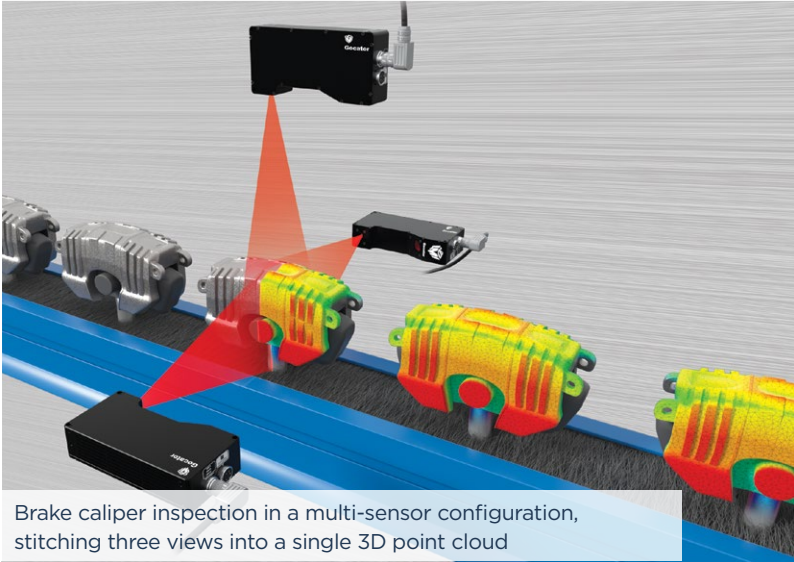

Brake caliper inspection in a multi-sensor configuration, stitching three views into a single 3D point cloud

WHY YOU NEED 3D GEOMETRY MEASUREMENT

Unlike 2D, 3D measurement produces geometry (i.e., shape) data that is required to determine if a part meets key assembly, fit, and finish tolerances.

PART MANUFACTURING INSPECTION

Extrusion Inspection

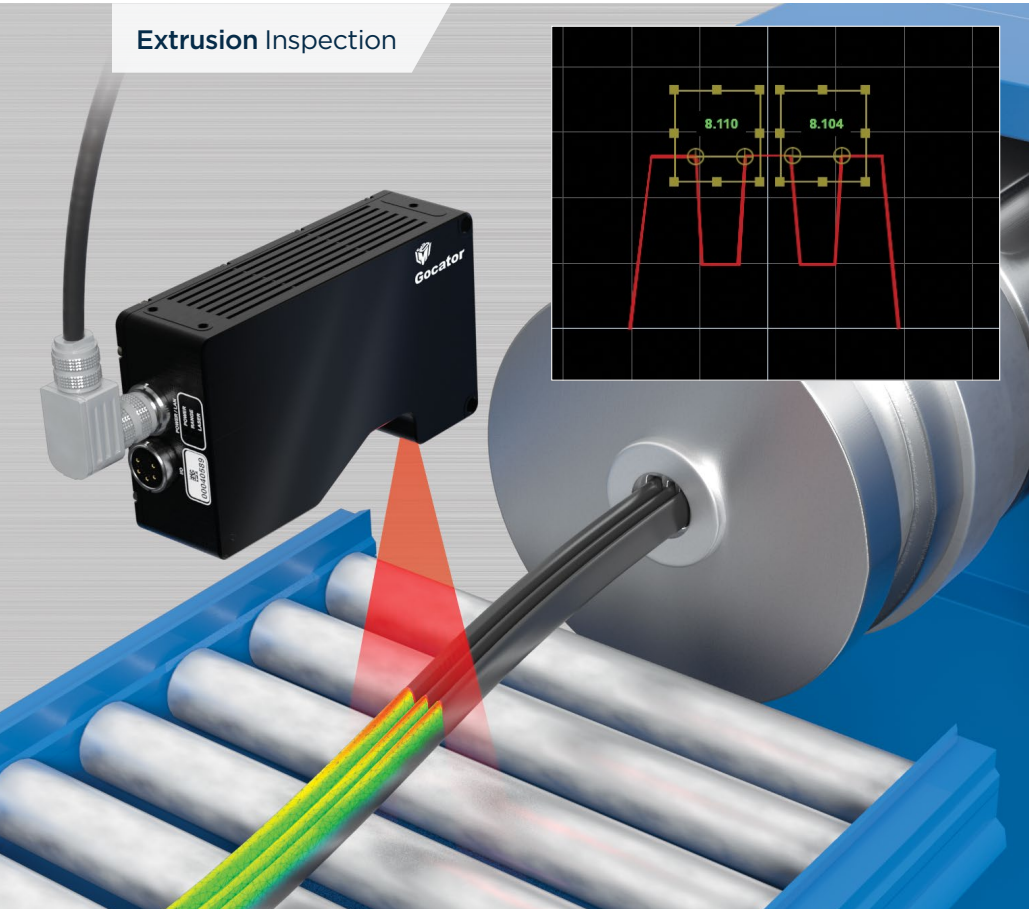

Laser line measurement of a plastic extrusion to ensure the correct spacing between teeth

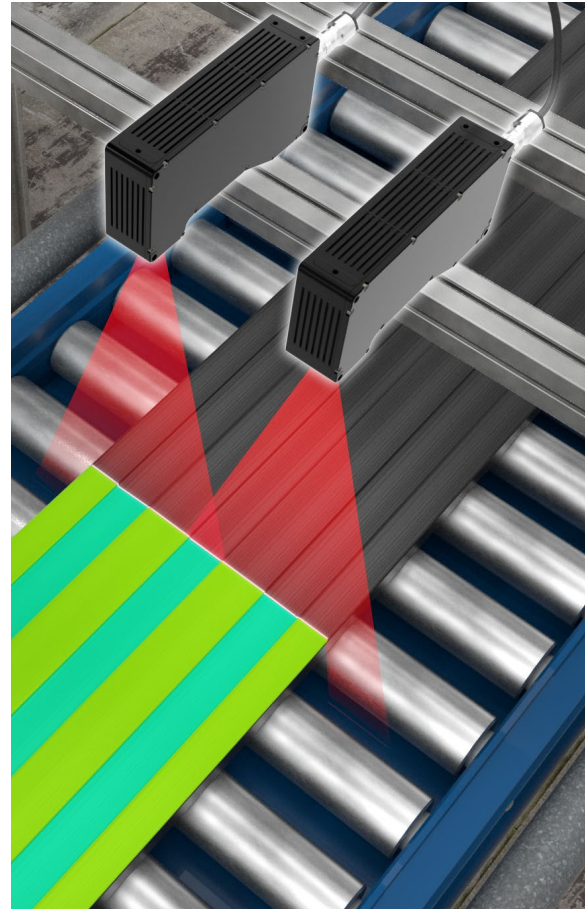

Rubber extrusion profiling



COMMON PROBLEM:
COMPLEX AND TIME-CONSUMING SYSTEM SETUP



FactorySmart® SOLUTION:
WEB-ENABLED TECHNOLOGIES AND ALL-IN-ONE DESIGN

- Connect to a sensor with any web browser.
- Generate scans of your object/feature with sophisticated control over triggering, exposure, resolution, part detection, and filtering/gap filling.
- Built-in drag and drop measurement for full geometric gauging.
- Ethernet protocols and direct I/O are built-in and communicate pass/fail decisions directly to factory equipment (robots, PLCs, or direct I/O).

3D Printing Inspection

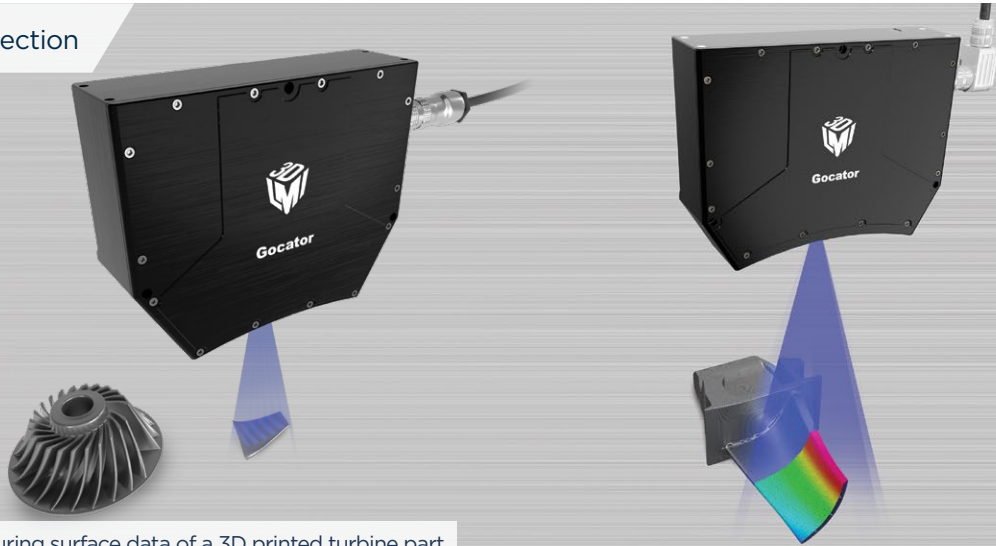

Snapshot sensor capturing surface data of a 3D printed turbine part

Helical Gear Inspection

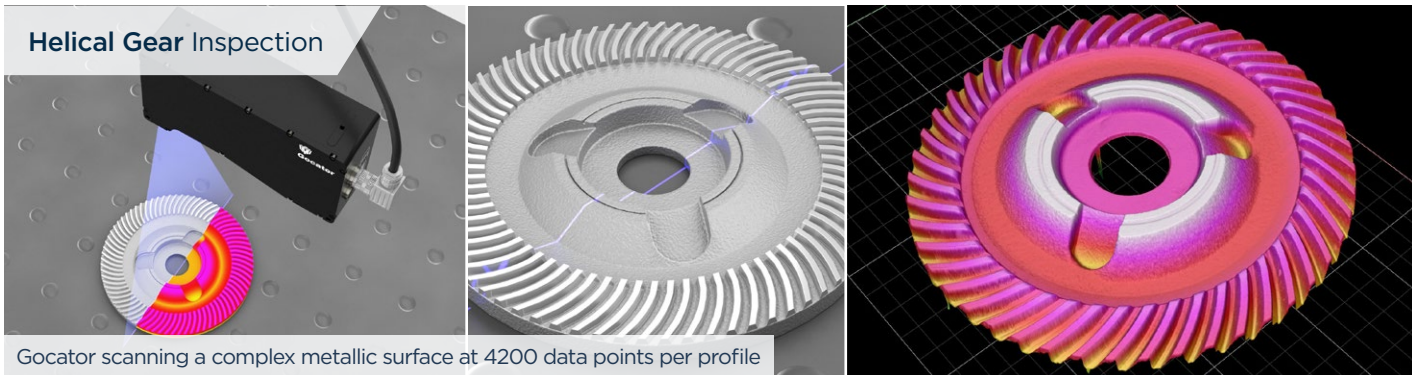

Gocator scanning a complex metallic surface at 4200 data points per profile



SMART BENEFIT: INDUSTRIAL SENSOR DESIGN FOR HIGH MEASUREMENT RELIABILITY AND LONG PRODUCT LIFE

- Rugged housing, small form factor, and lightweight design make Gocator sensors ideal for fitting into small spaces and mounting onto robots.
- IP67-rated design based on industrial grade parts offers long lifetimes in continuous operation.

WHY YOU NEED 3D THE BENEFIT OF COMBINING 2D + 3D

Gocator laser profilers combine 3D and 2D capability for total quality inspection. In addition to 3D shape measurements, the intensity of the projected laser light is used to create a 2D image of the surface of a part. This information can be used to extract surface markings like bar codes and printed text.

COMPONENT ASSEMBLY INSPECTION

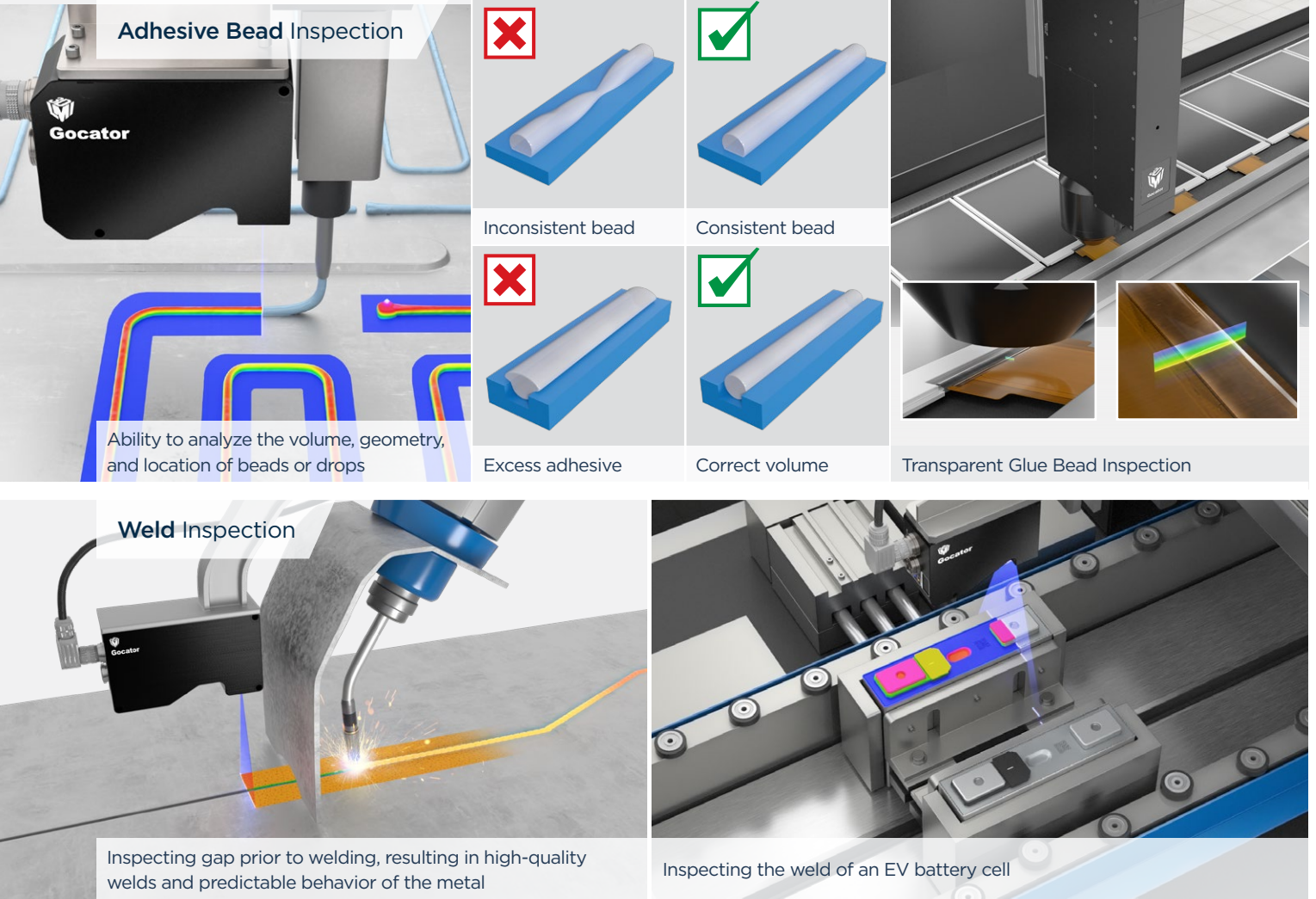

COMMON PROBLEM:
NO CUSTOM MEASUREMENT TOOLS



FactorySmart® SOLUTION:
GOCATOR DEVELOPMENT KIT (GDK)

- Develop and embed your own custom measurement tools and make specialized measurements for applications with unique requirements, while protecting your IP.
- Create optimized custom firmware builds that run within the realtime OS of the Gocator.
- Use custom solutions on a variety of different sensors, all on a single platform.
- Run your own measurement tools in the Gocator Emulator for offline development, testing, and support.

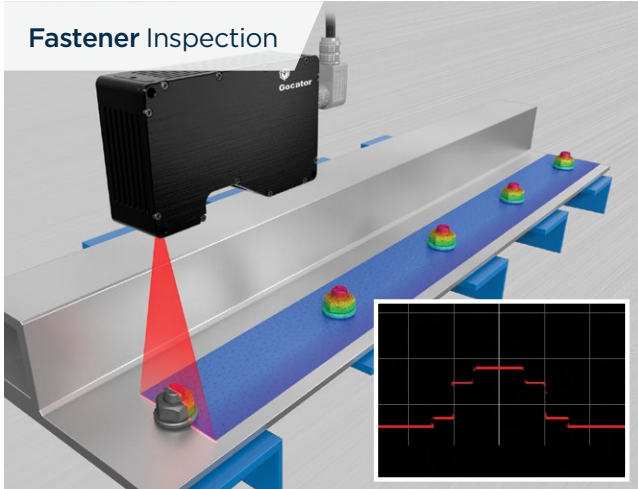

Fastener Inspection

Checking the tightness of a fastener through measurement of mating surface to nut surface

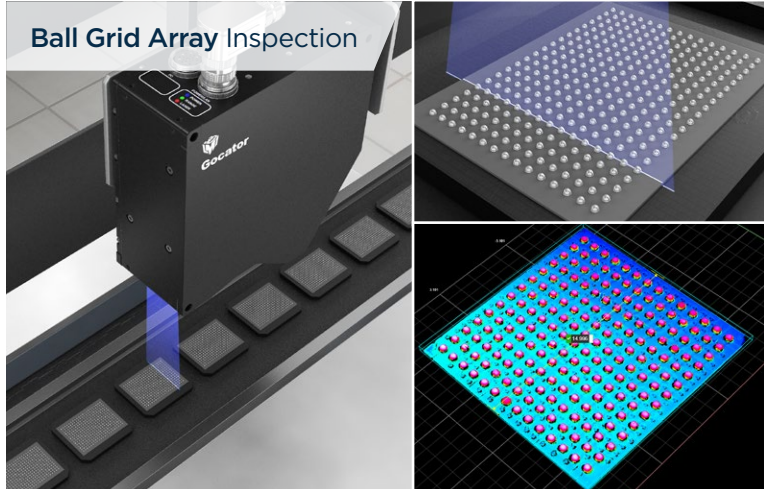

Ball Grid Array Inspection

BGA Ball Bump Inspection using a Gocator 6320. Telecentric line generation improves small defect and edge detection.



Solder Paste Inspection

Accuracy to 1.8 μm in height allows for high-precision measurement of solder paste.



Copper Coil Inspection

Snapshot sensor's dual cameras capture a detailed 3D scan with less occlusion of the fine copper coil ends



SMART BENEFIT:
HIGH-SPEED 3D PROFILING OF COMPLEX SHAPES

Laser profilers are high-speed devices that generate a line profile by combining range data from the scanned part. You can then easily perform measurements on the profile for dimensioning and inspecting complex shapes.

COMPONENT ASSEMBLY INSPECTION

SIM Card Tray Inspection

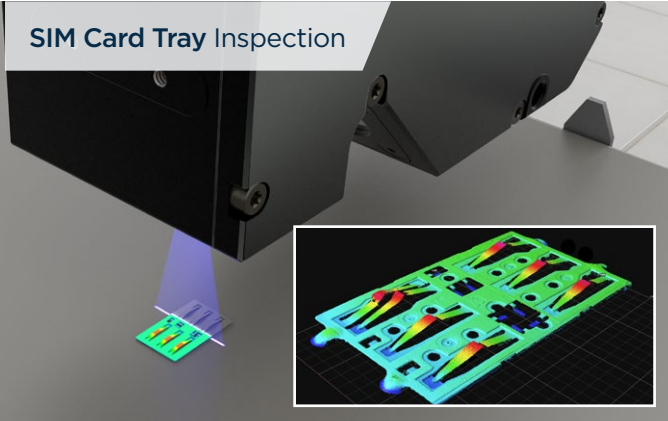

Inspect small complex parts at speeds up to 20 kHz

Wheel Stud Inspection

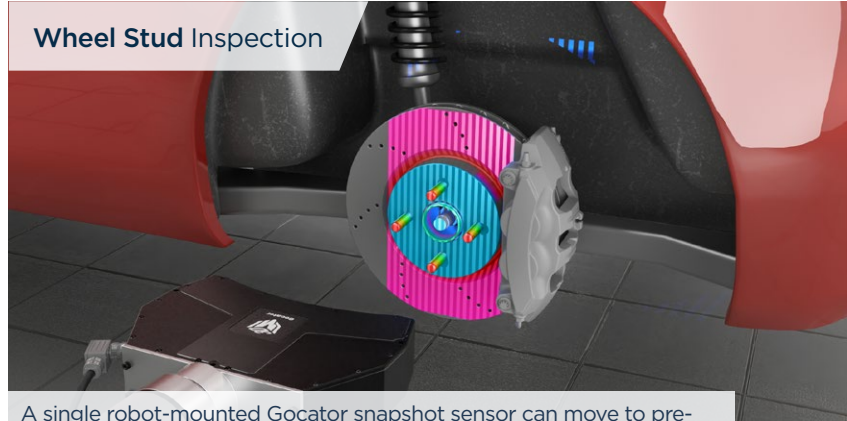

A single robot-mounted Gocator snapshot sensor can move to pre-determined positions and inspect multiple parts in seconds

Press Fit Inspection

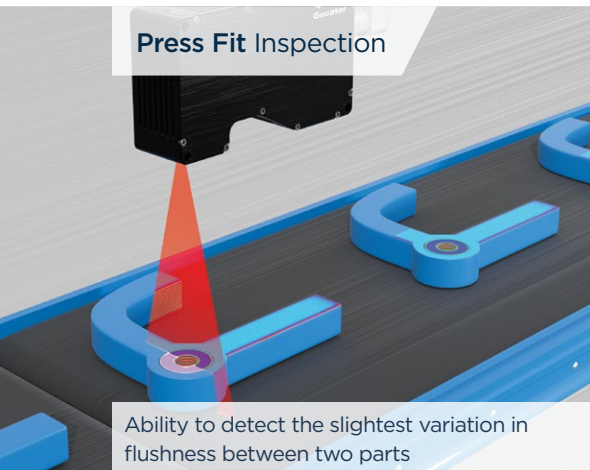

Ability to detect the slightest variation in flushness between two parts

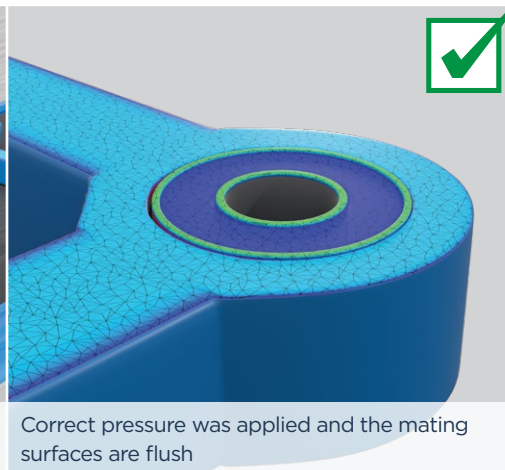

Correct pressure was applied and the mating surfaces are flush

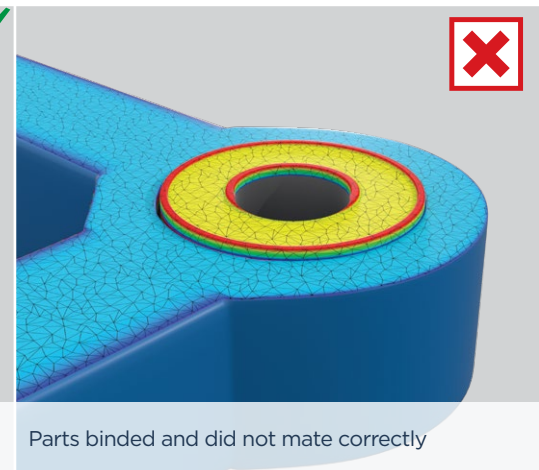

Parts banded and did not mate correctly



COMMON PROBLEM:
NO TIME OR RESOURCES TO CREATE AND DEPLOY YOUR OWN MEASUREMENT TOOLS



FactorySmart® SOLUTION:
BUILT-IN MEASUREMENT TOOLS

- Built-in measurement tools make 3D measurement reliable, repeatable, and easy.
- No need to send 3D point cloud data to 3rd-party software.
- Tools include Gap & Flush, Groove, Countersunk Hole, Surface Edge, Surface Plane, and many more.

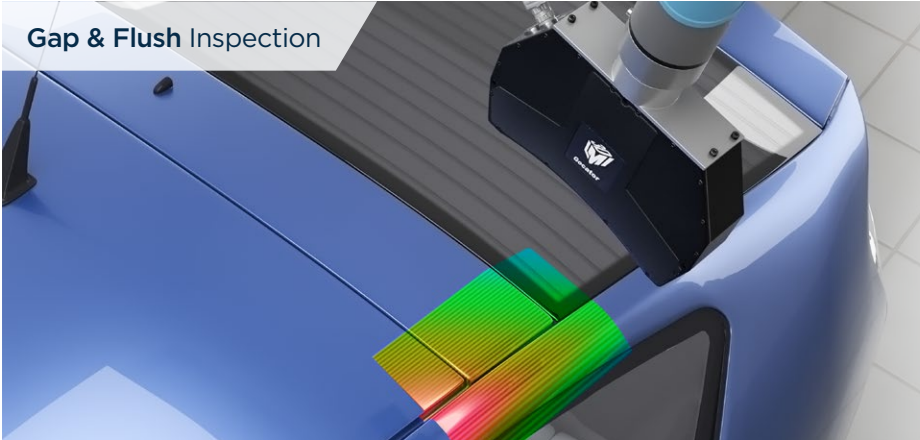

Gap & Flush Inspection

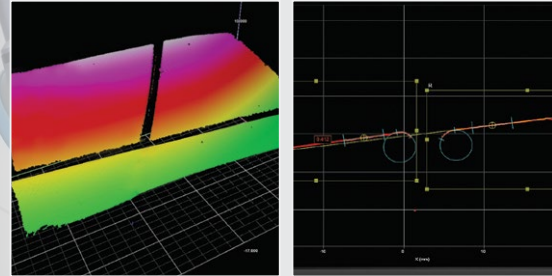

Snapshot sensors are able to measure multiple gap & flush features within a single field of view. 3D surface data is cross-sectioned and measured for multiple profile views.

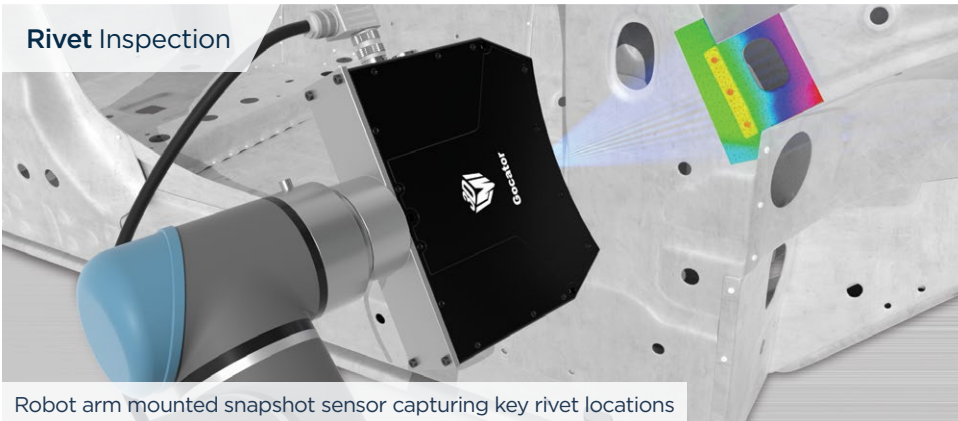

Rivet Inspection

Robot arm mounted snapshot sensor capturing key rivet locations

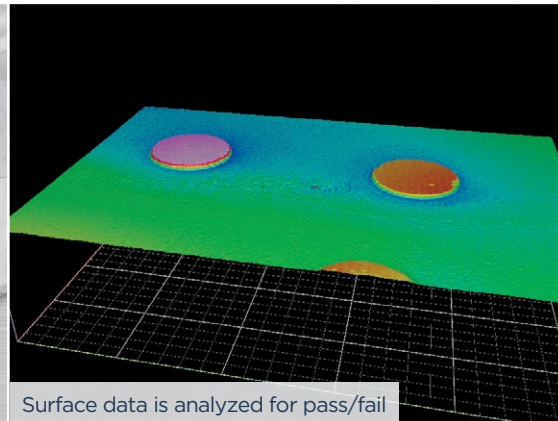

Surface data is analyzed for pass/fail



COMMON PROBLEM:
NEED VISION-GUIDANCE AND FLEXIBLE MEASUREMENT FOR ROBOTIC SYSTEMS



FactorySmart® SOLUTION:
ROBOT-FRIENDLY HARDWARE + SOFTWARE

- Gocator 3D smart sensors allow a robot to sense variations in its physical environment and adapt accordingly. Gocators are the “eyes” in vision guidance and enable essential applications such as pick-and-place.
- Gocator 3D snapshot sensors are certified for Universal Robots integration (UR3, UR5, UR10, and UR e-series compatible)

SURFACE & PACKAGING INSPECTION

Surface Finishing Inspection

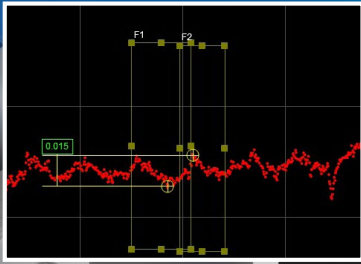

Inline surface inspection of brake rotors down to 1.1 μm Z resolution. Maximum and minimum height are measured, and an average is calculated to determine the acceptable surface finish.

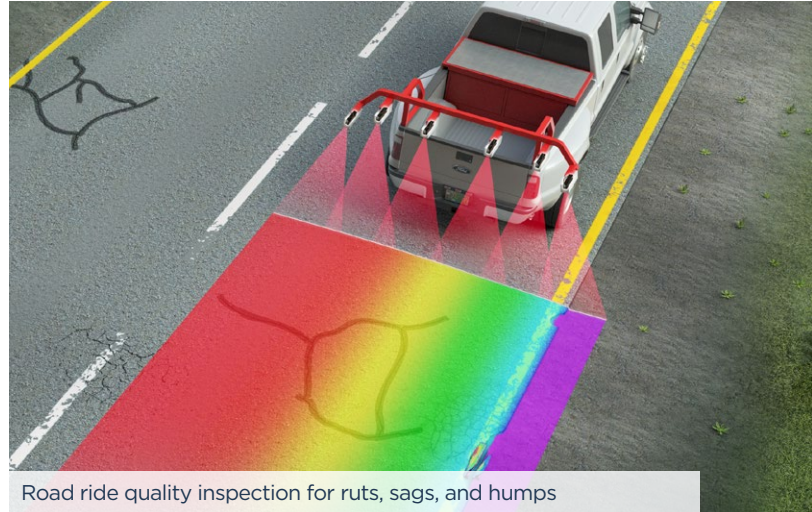

Road ride quality inspection for ruts, sags, and humps

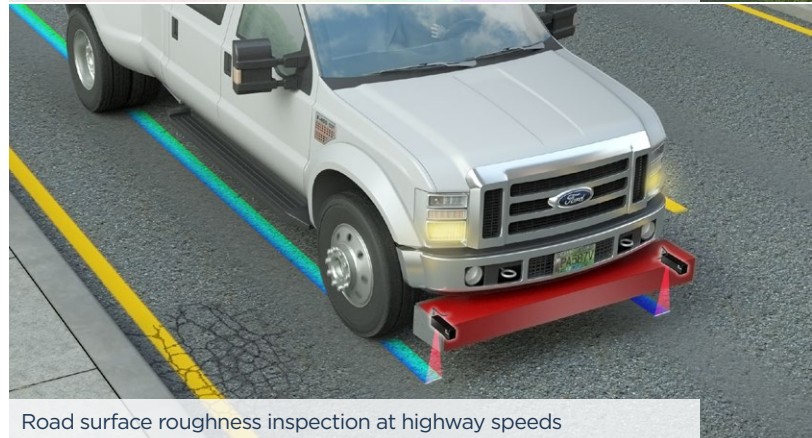

Road surface roughness inspection at highway speeds



SMART BENEFIT: HIGH-RESOLUTION 3D SHAPE AND SURFACE ANALYSIS

Line profilers generate a high-resolution 3D height map of the target object. Built-in tools allow you to easily perform micron-level measurements of the object's geometry and surface.

WHY YOU NEED 3D ACCURATE SCANNING EVEN WITH OBJECT MOVEMENT

Unlike 2D, 3D provides depth measurement information that prevents errors due to object movement—meaning objects can move anywhere within the sensor's measurement range and still yield accurate results. This eliminates object fixturing requirements and improves overall system reliability.

Packaging Inspection

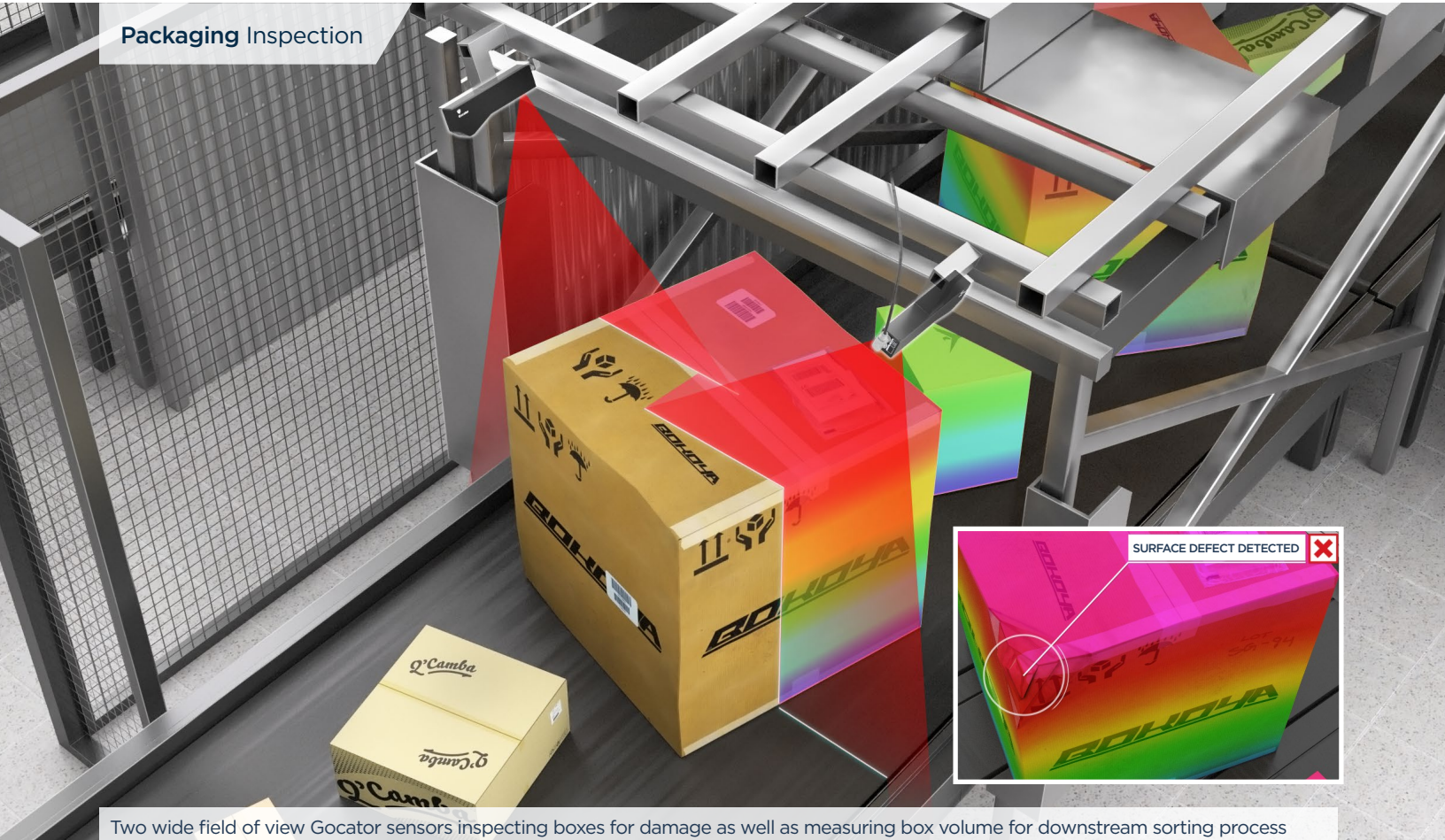

Two wide field of view Gocator sensors inspecting boxes for damage as well as measuring box volume for downstream sorting process



COMMON PROBLEM:
NEED TO MEET INLINE PRODUCTION SPEED



FactorySmart® SOLUTION:
SENSOR ACCELERATION

- Accelerate inspection by adding GoMax (a dedicated hardware device) or GoX (a PC-based application) to share the data processing load and achieve faster cycle times.

WHY YOU NEED 3D EASILY INSPECT LOW-CONTRAST OBJECTS

Unlike 2D intensity imaging, **3D is contrast invariant**. This means shape is measured regardless of surface colour—making 3D ideal for measuring low contrast objects. In addition, with 3D you don't have to worry about ambient lighting or shadows affecting your scan results.

PRODUCT FINISH & PACKAGING INSPECTION

Character Identification

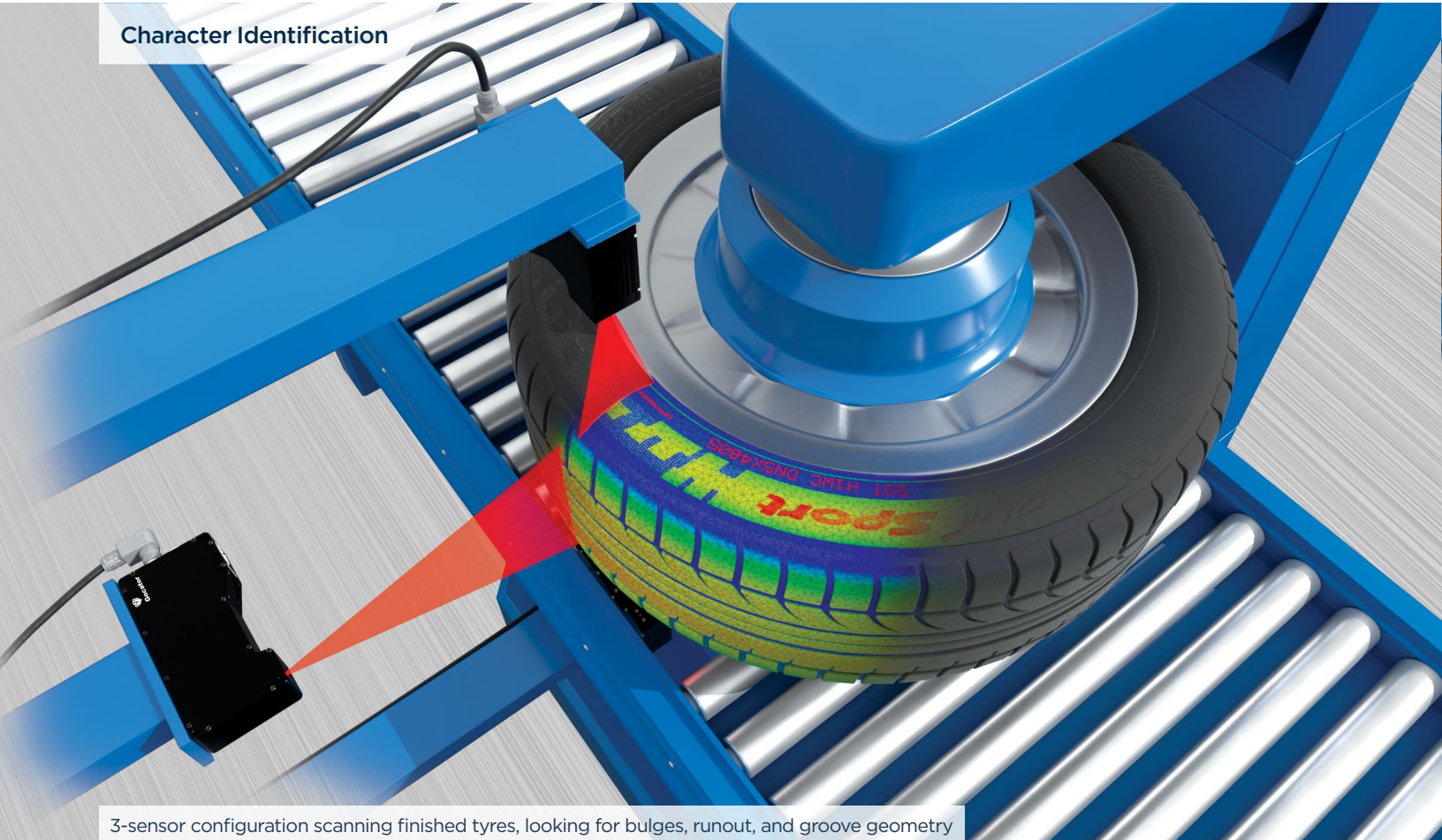

3-sensor configuration scanning finished tyres, looking for bulges, runout, and groove geometry



Low-contrast unscanned surface



Scanned tire with identifiable features



DOT-code is generated simultaneously from height data

OPTICAL CHARACTER RECOGNITION (OCR) AND BARCODE READING

Leverage the ability to read, recognize, and validate printed barcodes, labels, and alphanumeric text using 2D intensity or 3D height map (embossed) scan data.

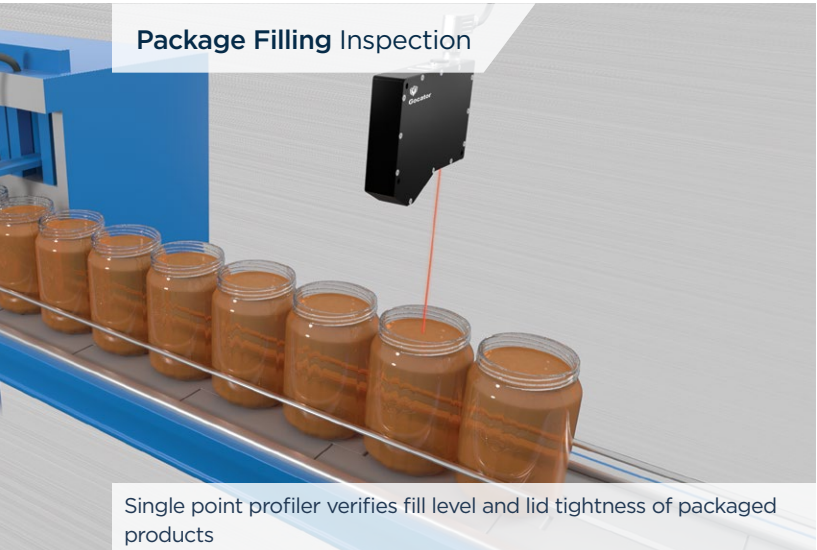

Package Filling Inspection

Single point profiler verifies fill level and lid tightness of packaged products

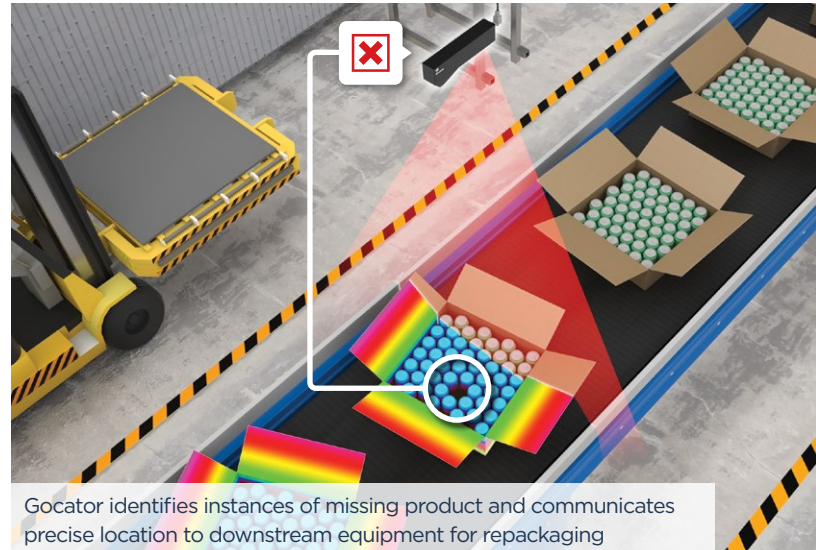

Gocator identifies instances of missing product and communicates precise location to downstream equipment for repackaging



Multi-Sensor Networking



COMMON PROBLEM:
TARGET IS LARGER THAN A SINGLE SENSOR CAN CAPTURE



FactorySmart® SOLUTION:
EASY MULTI-SENSOR NETWORKING

- A Master Hub synchronizes multiple Gocator sensors and combines scans into a single high-density 3D data of the entire surface or target object.
- Built-in alignment and stitching makes working with multiple sensors easy.
- Or, use the Surface Stitch tool to combine multiple scans from one sensor into a single 3D height map of a large object

GOCATOR® SMART 3D LINE CONFOCAL AND COAXIAL LINE CONFOCAL SENSORS

for Inspection of Challenging Materials



Gocator 4000 & 5500 Series

The Gocator 4000 Series sensors' coaxial design specializes in delivering high-speed, shadow-free, high angular acceptance performance for scanning tiny BGA solder ball bumps in semiconductor manufacturing. The Gocator 5500 Series' dual-axis design delivers high-speed, wide coverage 2K line scanning with simultaneous generation of 3D topography, 3D tomography, and 2D intensity data for measurement and inspection of multi-layer materials such as medical seals.

Consumer Electronics (CE)

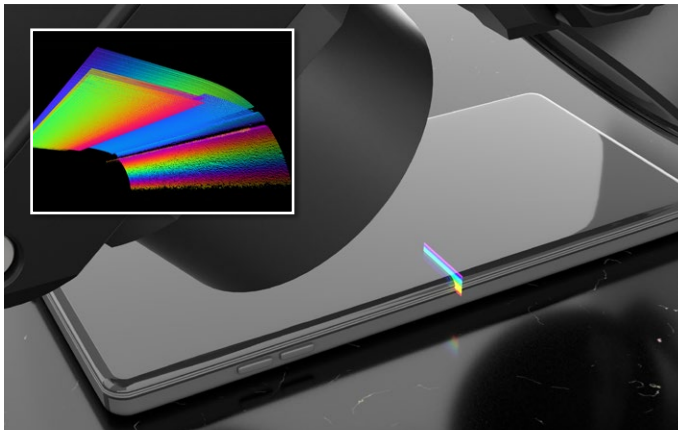

Multi-Layer Phone Display Glass Inspection

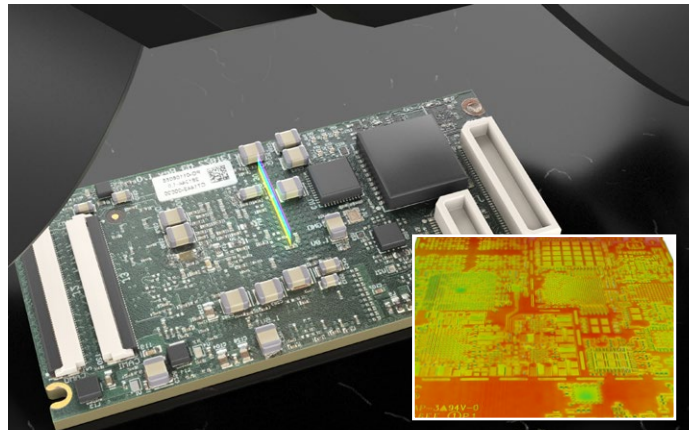

PCB Inspection

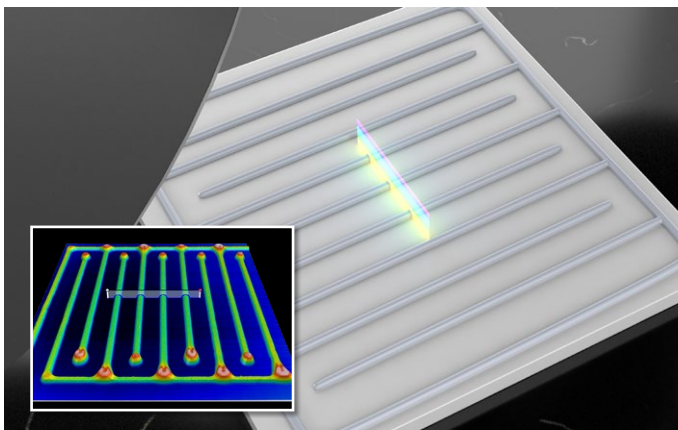

Glue Bead Volume/Position (Transparent/Translucent)

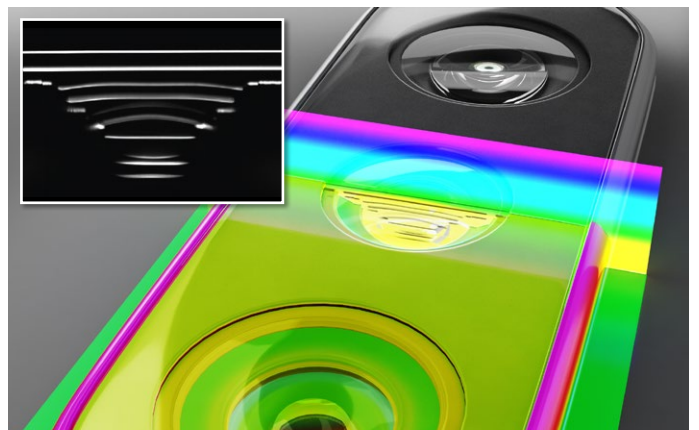

Multi-Layer Lens Assembly (Cell Phone Camera)

EV Battery Manufacturing

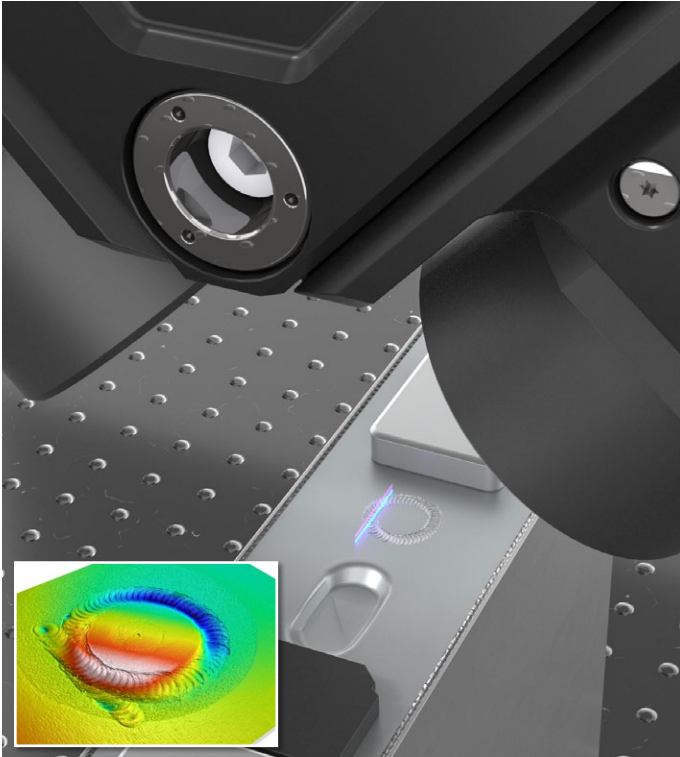

Weld Seam Inspection (Tab, Liquid Injection Port, Module Busbar)

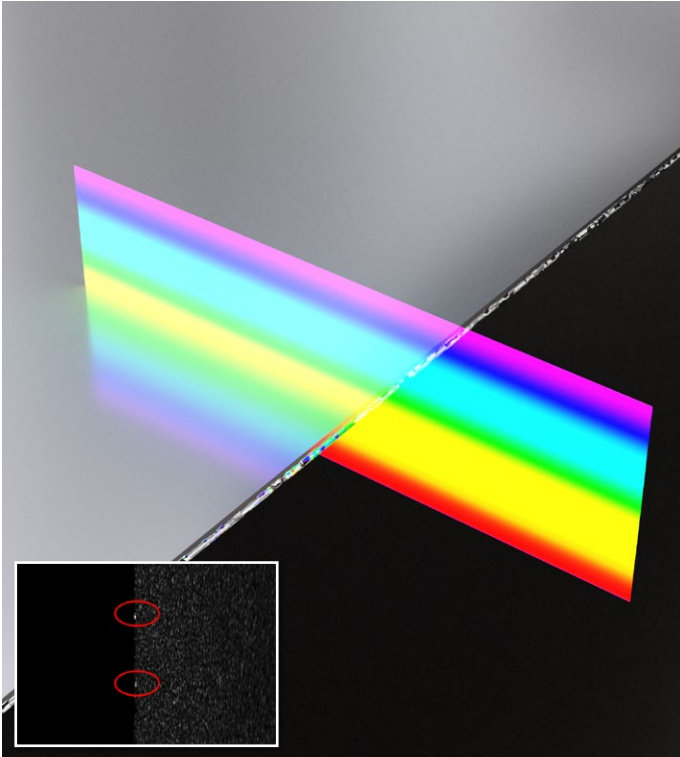

Burr Inspection

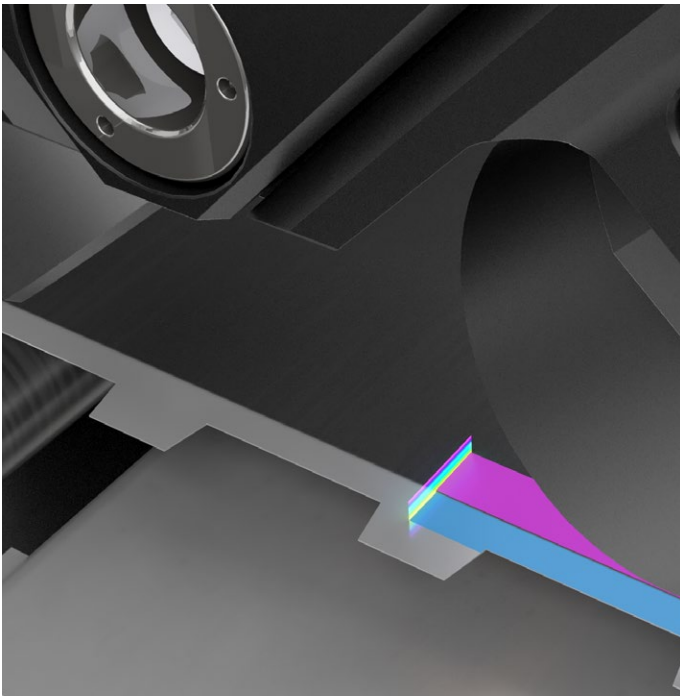

Electrode Coating Thickness Measurement

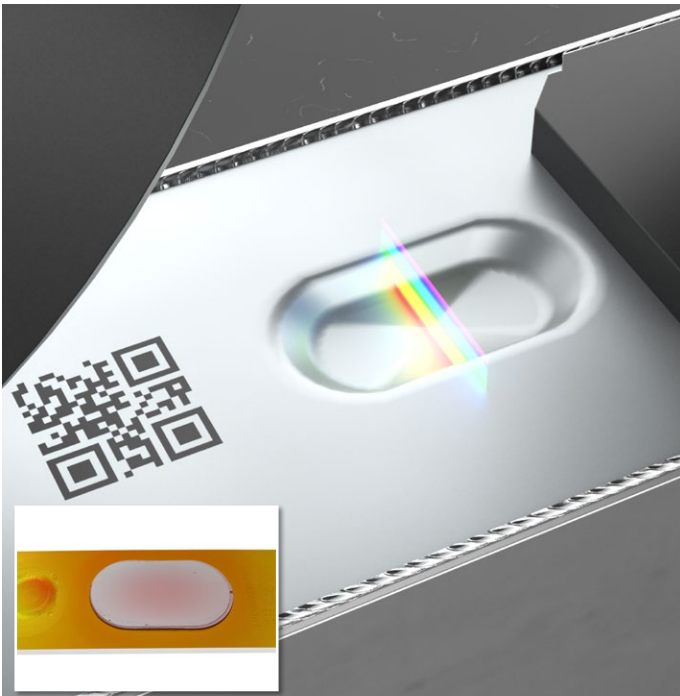

Explosion-Proof Valve Inspection (Multi-Layer)

GOCATOR® SMART 3D LINE CONFOCAL SENSORS for Inspection of Challenging Materials

Film & Coating

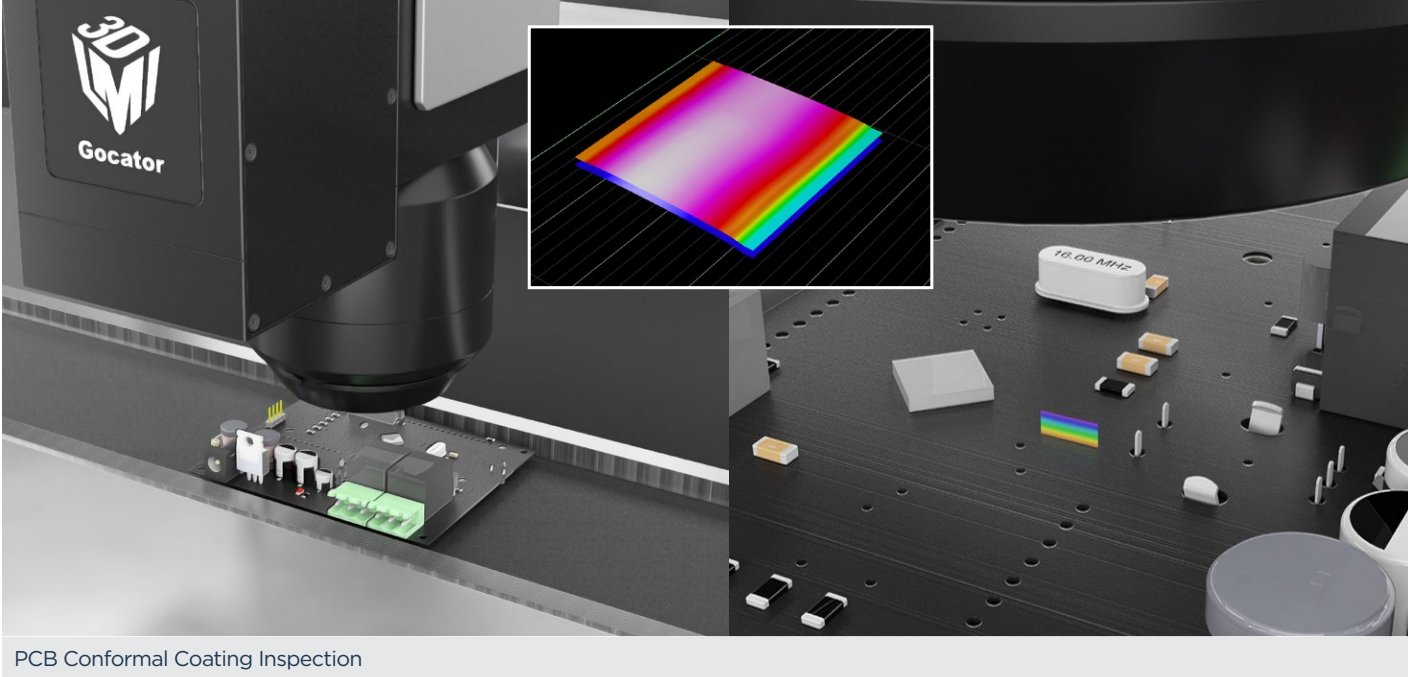
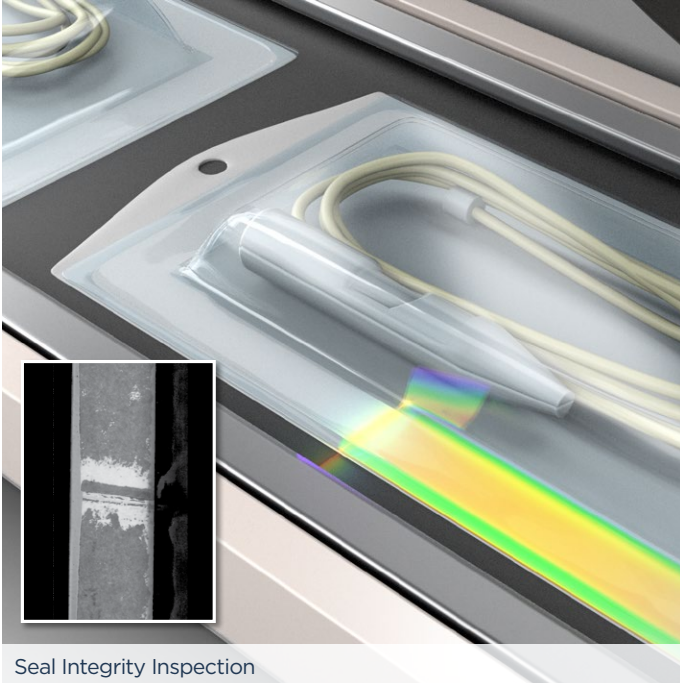
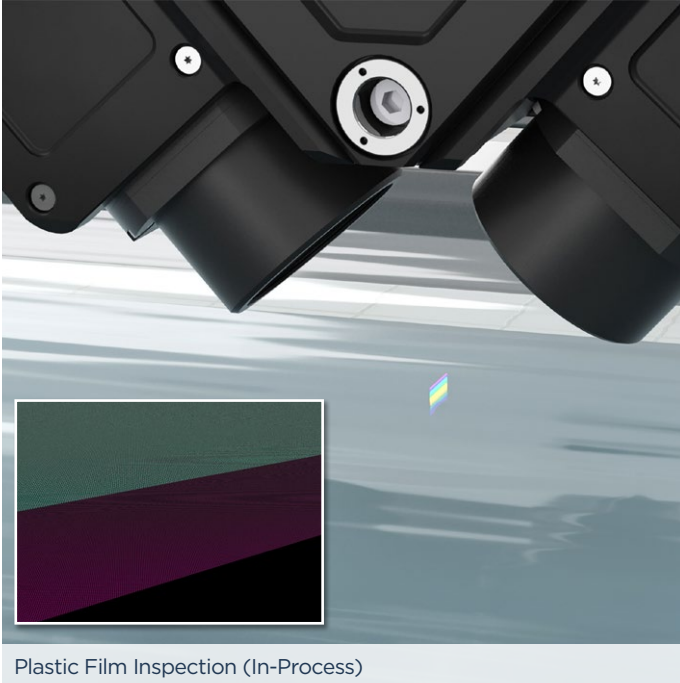

Semiconductor Manufacturing

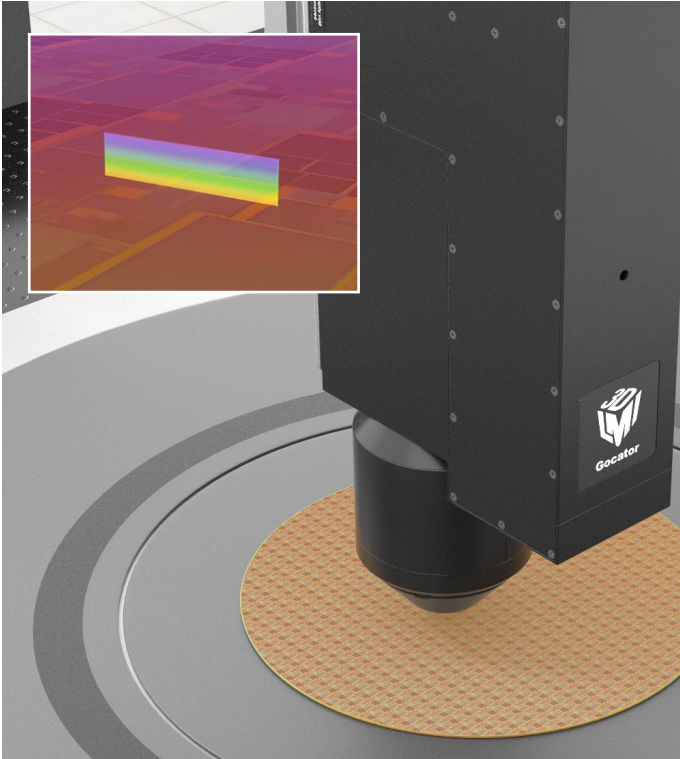

Silicon Wafer Inspection

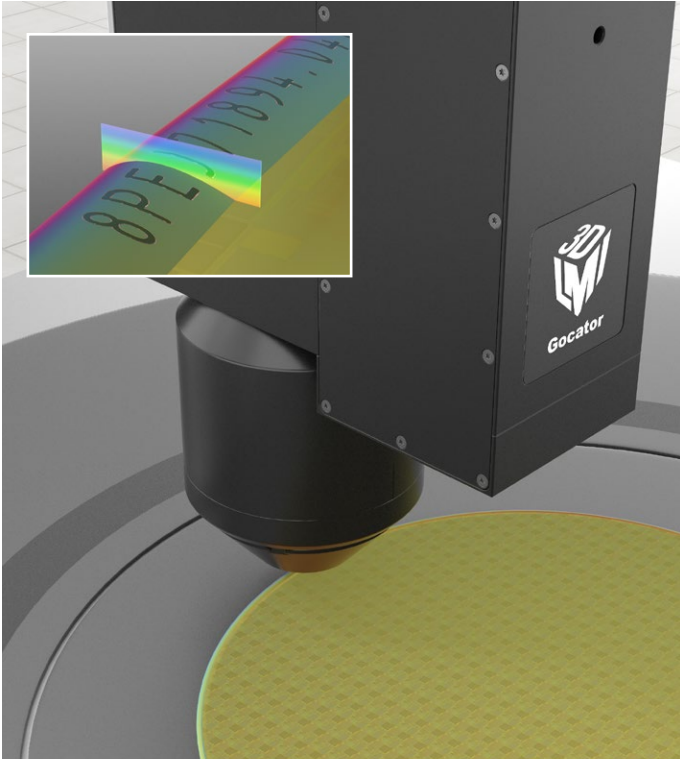

Silicon Wafer Character Code Identification

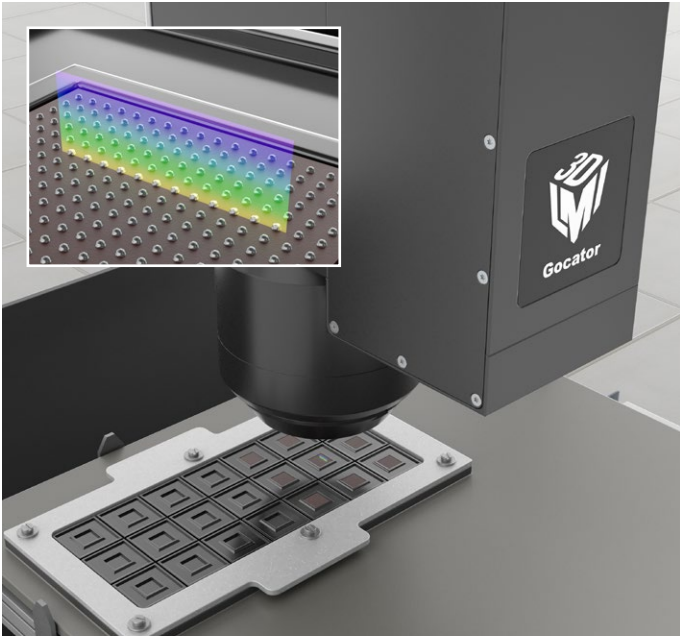

BGA Ball Bump Measurement

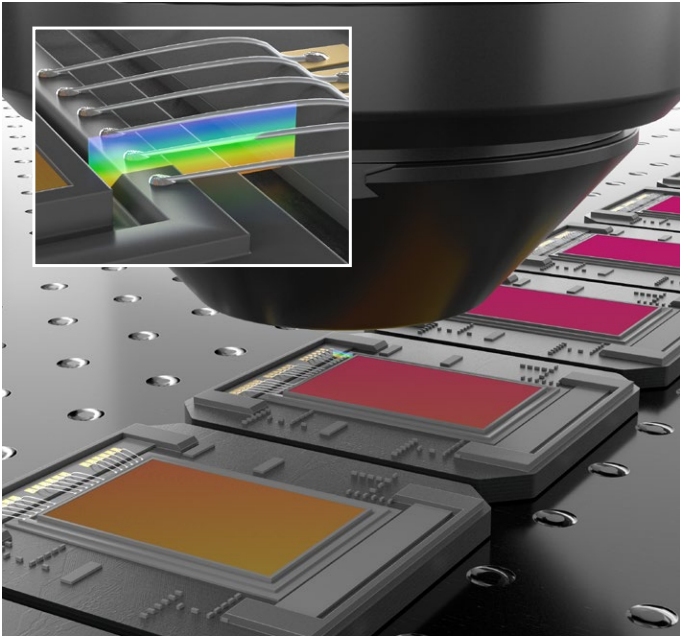

Wire Bonding Defect Detection

POWERFUL MEASUREMENT AND INSPECTION SOFTWARE

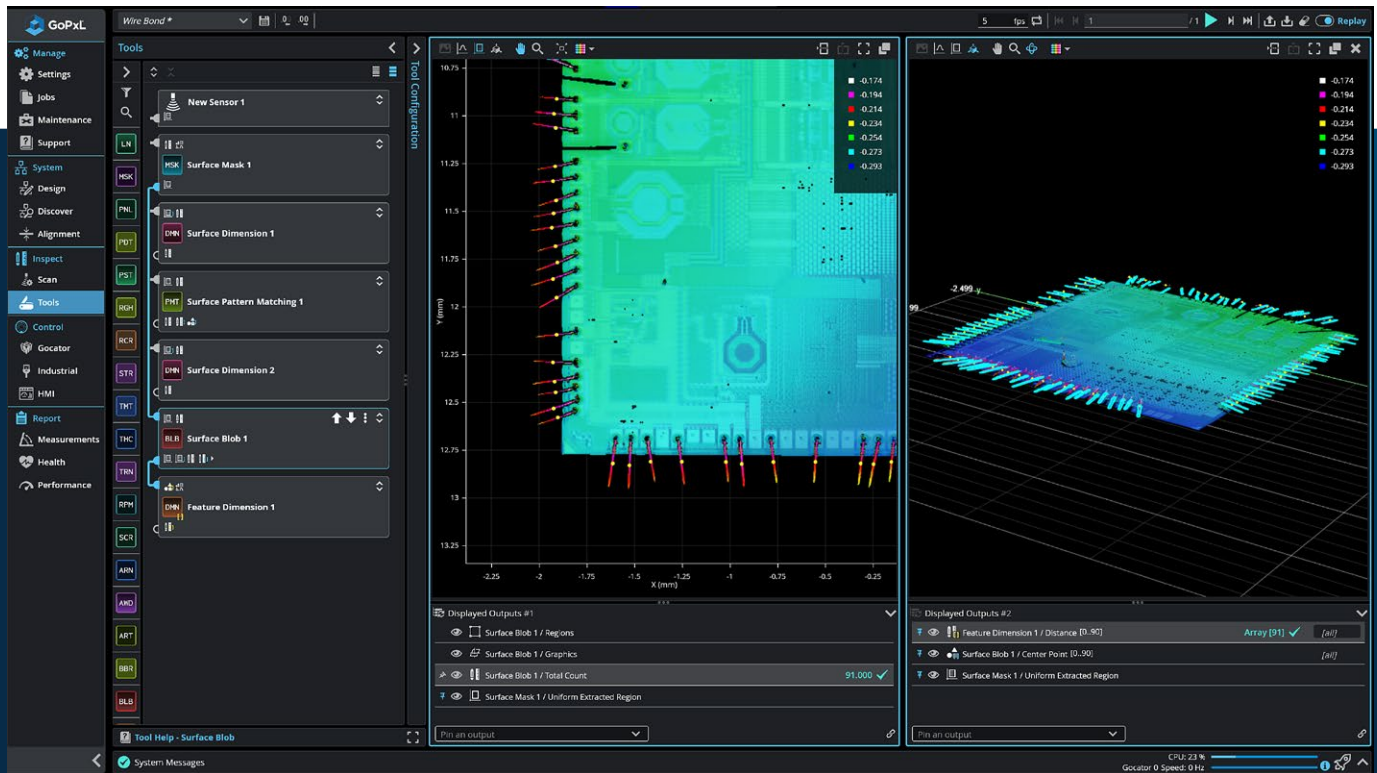

GoPxl® is our software application for creating end-to-end, web-based, inline measurement and inspection solutions deployed on a Gocator® 3D Smart Sensor.

Vision engineers can use GoPxl® to solve a wide range of industrial inspection tasks leveraging a combination of on-sensor measurement filters and tools running on Gocator's industry-leading laser, snapshot, and line confocal sensors. GoPxl takes advantage of 30 years of 3D experience at LMI to create a user experience that helps engineers develop measurement and inspection solutions more efficiently and effectively than ever before.



Scan



Align



Measure



Connect



Accelerate



Interface

Why Should You Try GoPxl

Create an accurate and repeatable measurement solution, without expert machine vision or 3D knowledge and experience

Extract real world measurements directly from the sensor and connect outcomes and decisions to PLC using industrial protocols

Create a custom end-user interface connected to Gocator outputs and accessed using a browser on PC, touchscreen, or mobile device

DEPLOYED ON GOCATOR® 3D SMART SENSORS



Embedded Tool Help

Access help resources without leaving the application.



Multi-layer Scanning Capability

Scan, measure, and inspect multi-layered material structures with Gocator line confocal sensors.



Sensor Alignment Wizard

A built-in wizard makes single and multi-sensor alignment easier than ever.



Script Tool

Create custom processing logic for measurement values, surfaces, profiles, or geometric features

```
Code
1 import numpy as np
2 import csv
3
4 # Get measurement array from input (Surface Position)
5 measurement = get_measurement(0)
6 measurement_array = []
7 for i in measurement:
8     measurement_array.append(i.value)
9
10 # Get threshold array from C:\GoTools\Script\script_threshold.csv
11 csv_file_path = 'C:\GoTools\Script\script_threshold.csv'
12 threshold_array = []
```



Array Decision Tool

Apply measurements and output decisions on similar surfaces such as battery cells.

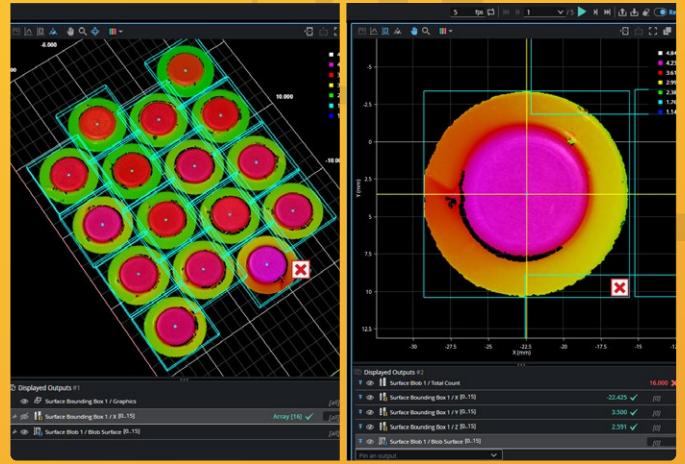

Region Types

Use circle and ellipse region types to apply tools and filters on circular objects.



Data Export Tool

On PC, you can use the new Data Export tool to save scan data to a file for importing into other applications.



Searchable Tools

Find the measurements tools you're looking for quickly and easily.

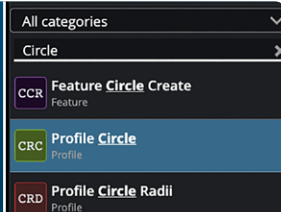

NOTE: While users are encouraged to evaluate GoPXL, previous Gocator firmware releases will continue to be supported and maintained. G2 and G3 products are currently shipping with Gocator firmware 6.1.42.10 or later.



Profile Roughness Tool

The new Profile Roughness tool allows you to calculate measurements of profile roughness according to several different industry standards.

- ✓ Web browser based interface
- ✓ OS independent
- ✓ 140+ Tools at your disposal

PRODUCT LINEUP

LASER PROFILE SENSORS



Gocator 1300 Series

High-speed (32 kHz) Point Profilers for Dimensional Measurements

- Unique built-in part detection and profile generation
- Ideal for closed loop control or measuring high speed processes



Gocator 2100 Series

Low Cost, Entry-Level Line Profilers for Basic Inline 3D Inspection

- Handles all of your basic quality inspection needs
- VGA imager, 640 points per profile resolution
- Field of view up to 1260 mm
- Measurement range up to 800 mm



Gocator 2300 Series

Workhorse Line Profilers for Robust Inline 3D Inspection

- Handles a wide range of applications
- Megapixel imager, 1280 points per profile resolution
- Field of view up to 1260 mm
- Measurement range up to 800 mm



Gocator 2400 Series

High-Resolution Line Profilers for Advanced Inline 3D Inspection

- Handles difficult targets such as micro-features on small parts in high-speed applications
- 2-Megapixel imager, up to 1940 points per profile resolution
- Field of view up to 2000 mm
- Measurement range up to 1525 mm



Gocator 2500 Series

Ultra High-Speed Line Profilers for Small Parts 3D Inspection

- Ideal for fast-moving inline inspection systems
- 2-Megapixel imager. Up to 1920 points per profile resolution
- Scan, measurement, and control at up to 20 kHz
- Field-of-view up to 518 mm
- Measurement range up to 595 mm



Gocator 2600 Series

Ultra High-Resolution 4K+ Line Profilers with Wide Fields of View

- Handles microscopic features and large scan targets
- 9-megapixel imager, 4192 data points per profile resolution
- Field of view up to 2 m
- Measurement range up to 1550 mm

LASER PROFILE SENSORS



Gocator 6300 Series

The Ultimate Laser Line Profile Sensors

- Over 6500 Points per Profile for Precision 2D/3D Measurement and Inspection
- X Profile Data Interval Down to <math><2.1</math> Microns (at 13.4 mm FOV)
- Scan rate > 1.8 kHz full-frame (FOV/MR)
- Field of View up to 31 mm (at <math><4.3</math> microns X Profile Data Interval)
- On-sensor Measurement Tools and I/O Connectivity
- Native Multi-Sensor Alignment and Networking Support

COAXIAL LINE CONFOCAL SENSORS



Gocator 4000 Series

Smart 3D Line Confocal Imaging. Now in a Coaxial Design.

- 1920 points per profile for high-resolution, shadow-free 3D measurement and inspection
- X resolutions up to 1.9 microns
- Fields of view up to 5.0 millimeters
- Max slope angle up to ± 85 degrees
- Scan Rates Up to 36 kHz (with Acceleration)
- On-sensor measurement tools and I/O connectivity
- Easy mounting and system integration

LINE CONFOCAL SENSORS



Gocator 5500 Series

Smart 3D Line Confocal Sensors for Challenging Material Inspection

- Simultaneous Generation of Multiple Profiles from Multi-Layer Structures
- Generates 1792 Data Points per Profile
- Scan Rates Up to 40 kHz (with Acceleration)
- Handles Wide Variety of Material Types
- Dual-Axis Optical Design Provides Higher Signal Quality
- Runs LMI's Next Generation Measurement and Inspection Software

SNAPSHOT SENSORS



Gocator 3500 and 3200 Series

High-Density 3D Snapshot Sensors for Small and Medium Parts Inspection

- Fast scan rate (up to 6 Hz full field with acceleration)
- XY resolution down to 20 μm
- Z repeatability down to 2 μm
- Wide field of view up to 282 x 175 mm
- 2 or 5 megapixel stereo cameras for high accuracy with minimal occlusions

PRODUCT SPECS

Gocator 1300 Series		Laser Point Profile					
MODELS	1320	1340	1350	1365	1370	1380	1390
Clearance Distance (mm)	40	162.5	200	562	2375	127	500
Measurement Range (mm)	20	95	200	375	412.5	1651	2000
Linearity Z (± % of MR)	0.05	0.05	0.05	0.11	0.07	0.18	0.1
Linearity Z (± mm)	0.01	0.05	0.1	0.4	0.3	3.0	2.0
Resolution Z (mm)	0.0004 - 0.0004	0.0005 - 0.0010	0.0015 - 0.0035	0.0025 - 0.0040	0.0025 - 0.0070	0.0100 - 0.0450	0.0250 - 0.0600
Spot Size (mm)	0.11	0.37	0.50	1.80	0.90	2.60	2.60
Recommended Package Dimensions (mm)	Side Mount (3R) 30x120x149	Side Mount 30x120x149	Side Mount 30x120x149	Side Mount 30x120x220	Side Mount (3B) 30x120x149	Side Mount 30x120x149	Side Mount 30x120x277
Other Package Dimensions (mm)	Top Mount (3B) 49x75x162		Top Mount 49x75x162		Top Mount (2M) 49x75x162		
Weight (kg)	0.75 / 0.8	0.75	0.75 / 0.8	1.0	0.75 / 0.8	0.75	1.25

Resolution Z based on averaging 128 samples. Optical models, laser classes, and packages can be customized. Contact LMI for more details. Specifications stated are based on standard laser classes. Resolution Z and Linearity Z may vary for other laser classes. Refer to specifications in the Gocator Point Profile Sensor user manual for more details.

ALL 1300 SERIES MODELS

Scan Rate	32,000 Hz
Interface	Gigabit Ethernet
Inputs	Differential Encoder, Laser Safety Enable, Trigger
Outputs	2x Digital Output, RS-485 Serial, Selcom Serial, 1x Analog Output (4-20mA)
Factory Communication	PROFINET, Modbus, EtherNet/IP, ASCII, Gocator
Input Voltage (Power)	+24 to +48 VDC (13 Watts); Ripple ± 10%
Housing	Gasketed aluminum enclosure, IP67
Operating Temperature	0 to 50 °C
Storage Temperature	-30 to 70 °C
Vibration Resistance	10 to 55 Hz, 1.5 mm double amplitude in X, Y, and Z directions, 2 hours per direction
Shock Resistance	15 g, half sine wave, 11 ms, positive and negative for X, Y, and Z directions
Scanning Software	Browser-based GUI and open source SDK for configuration and real-time 3D visualization. Open source SDK, native drivers, and industrial protocols for integration with user applications, third-party image processing applications, and PLCs.

Gocator 2100 Series		Laser Line Profile				
MODELS	2120	2130	2140	2150	2170	2180
Data Points / Profile	640	640	640	640	640	640
Linearity Z (± % of MR)	0.01	0.01	0.01	0.01	0.04	0.04
Resolution Z (mm)	0.0018-0.0030	0.006 - 0.014	0.013 - 0.037	0.019 - 0.060	0.055 - 0.200	0.092 - 0.488
Resolution X (mm) (Profile Data Interval)	0.028-0.042	0.088 - 0.150	0.19 - 0.34	0.3 - 0.6	0.55 - 1.10	0.75 - 2.20
Repeatability Z (µm)	0.4	0.8	1.2	2	8	12
Clearance Distance (CD) (mm)	40	90	190	300	4 00	350
Measurement Range (MR) (mm)	25	80	210	400	500	800
Field of View (FOV) (mm)	18 - 26	47 - 85	96 - 194	158 - 365	308 - 687	390 - 1260
Dimensions (mm)	Side Mount 35x120x149.5	Top Mount 49x75x142	Top Mount 49x75x197	Top Mount 49x75x272	Top Mount 49x75x272	Top Mount 49x75x272
Weight (kg)	0.8	0.74	0.94	1.3	1.3	1.3

Optical models, laser classes, and packages can be customized. Contact LMI for more details. Specifications stated are based on standard laser classes. Linearity Z, Resolution Z, and Repeatability Z may vary for other laser classes. Refer to specifications in the Gocator Line Profile Sensor user manual for more details.

ALL 2100 SERIES MODELS

Scan Rate	Approximately 170 Hz to 5000 Hz
Interface	Gigabit Ethernet
Inputs	Differential Encoder, Laser Safety Enable, Trigger
Outputs	2x Digital output, RS-485 Serial (115 kBaud)
Factory Communication	PROFINET, Modbus, EtherNet/IP, ASCII, Gocator
Input Voltage (Power)	+24 to +48 VDC (13 Watts); Ripple ± 10%
Housing	Gasketed aluminum enclosure, IP67
Operating Temperature	0 to 50°C
Storage Temperature	-30 to 70°C
Vibration Resistance	10 to 55 Hz, 1.5 mm double amplitude in X, Y, and Z directions, 2 hours per direction
Shock Resistance	15 g, half sine wave, 11 ms, positive and negative for X, Y, and Z directions
Scanning Software	Browser-based GUI and open source SDK for configuration and real-time 3D visualization. Open source SDK, native drivers, and industrial protocols for integration with user applications, third-party image processing applications, and PLCs.

Gocator 2300 Series		Laser Line Profile				
MODELS	2320	2330	2340	2350	2370	2380
Data Points / Profile	1280	1280	1280	1280	1280	1280
Linearity Z (\pm % of MR)	0.01	0.01	0.01	0.01	0.04	0.04
Resolution Z (mm)	0.0018 - 0.0030	0.006 - 0.014	0.013 - 0.037	0.019 - 0.060	0.055 - 0.200	0.092 - 0.488
Resolution X (mm) (Profile Data Interval)	0.014 - 0.021	0.044 - 0.075	0.095 - 0.170	0.150 - 0.300	0.275 - 0.550	0.375 - 1.100
Repeatability Z (μ m)	0.4	0.8	1.2	2	8	12
Clearance Distance (CD) (mm)	40	90	190	300	400	350
Measurement Range (MR) (mm)	25	80	210	400	500	800
Field of View (FOV) (mm)	18 - 26	47 - 85	96 - 194	158 - 365	308 - 687	390 - 1260
Dimensions (mm)	Side Mount 35x120x149.5	Top Mount 49x75x142	Top Mount 49x75x197	Top Mount 49x75x272	Top Mount 49x75x272	Top Mount 49x75x272
Weight (kg)	0.8	0.74	0.94	1.3	1.3	1.3

Optical models, laser classes, and packages can be customized. Contact LMI for more details. Specifications stated are based on standard laser classes. Linearity Z, Resolution Z, and Repeatability Z may vary for other laser classes. Refer to specifications in the Gocator Line Profile Sensor user manual for more details.

ALL 2300 SERIES MODELS

Scan Rate	Approximately 170 Hz to 5000 Hz
Interface	Gigabit Ethernet
Inputs	Differential Encoder, Laser Safety Enable, Trigger
Outputs	2x Digital output, RS-485 Serial (115 kBaud)
Factory Communication	PROFINET, Modbus, EtherNet/IP, ASCII, Gocator
Input Voltage (Power)	+24 to +48 VDC (13 Watts); Ripple \pm 10%
Housing	Gasketed aluminum enclosure, IP67
Operating Temperature	0 to 50°C
Storage Temperature	-30 to 70°C
Vibration Resistance	10 to 55 Hz, 1.5 mm double amplitude in X, Y, and Z directions, 2 hours per direction
Shock Resistance	15 g, half sine wave, 11 ms, positive and negative for X, Y, and Z directions
Scanning Software	Browser-based GUI and open source SDK for configuration and real-time 3D visualization. Open source SDK, native drivers, and industrial protocols for integration with user applications, third-party image processing applications, and PLCs.

Gocator 2400 Series		Laser Line Profile				
MODELS	2410	2420	2430	2440	2450	2490
Data Points / Profile	1710	1940	1500	1500	1800	1920
Linearity Z (\pm % of MR)	0.015	0.006	0.01	0.01	0.01	0.04
Resolution X (μ m) (Profile Data Interval)	5.8 - 6.2	14.0 - 16.5	37 - 57	67 - 130	100 - 255	250 - 1100
Repeatability Z (μ m)	0.2	0.4	0.8	1.2	2.0	12
Clearance Distance (CD) (mm)	19	60	75	183	270	350
Measurement Range (MR) (mm)	6	25	80	210	550	1525
Field of View (FOV) (mm)	10 - 10	27 - 32	47 - 85	96 - 194	145 - 425	390 - 2000
Dimensions (mm)	44x90x145	44x90x145	44x90x155	44x90x190	44x90x240	49x85x272
Weight (kg)	0.88	0.88	1.0	1.2	1.2	1.5

Optical models, laser classes, and packages can be customized. Contact LMI for more details. Specifications stated are based on Recommended laser classes. Linearity Z, Resolution Z, and Repeatability Z may vary for other laser classes.

ALL 2400 SERIES MODELS

Scan Rate	200 Hz, up to 5 kHz. (Note: 2400 series provides up to 2x scan rate for equivalent window size as 2300 series)
Interface	Gigabit Ethernet
Inputs	Differential Encoder, Laser Safety Enable, Trigger
Outputs	2x Digital output, RS-485 Serial (115 kBaud)
Factory Communication	PROFINET, Modbus, EtherNet/IP, ASCII, Gocator
Input Voltage (Power)	+24 to +48 VDC (9 Watts); Ripple \pm 10%
Housing	Gasketed aluminum enclosure, IP67
Operating Temperature	0 to 50°C (10 to 50°C for Class 2 Blue)
Storage Temperature	-30 to 70°C
Vibration Resistance	10 to 55 Hz, 1.5 mm double amplitude in X, Y, and Z directions, 2 hours per direction
Shock Resistance	15 g, half sine wave, 11 ms, positive and negative for X, Y, and Z directions
Scanning Software	Browser-based GUI and open source SDK for configuration and real-time 3D visualization. Open source SDK, native drivers, and industrial protocols for integration with user applications, third-party image processing applications, and PLCs.

PRODUCT SPECS

LASER PROFILE SENSORS

Gocator 2500 Series Laser Line Profile

MODELS	2510	2512	2513	2520	2522	2525	2530	2540	2550
Data Points / Profile	1920	1920	600	1920	1920	1920	1920	1920	1920
Scan Rate (Hz) ⁽¹⁾	2400 - 20,000	1600 - 20,000	14,500 - 20,000	1600 - 20,000	1600 - 20,000	1800 - 20,000	2000 - 20,000	1700 - 20,000	1800 - 20,000
Linearity Z (± % of MR) ⁽²⁾	0.015	0.015	0.019	0.006	0.006	0.01	0.01	0.05	0.06
Resolution X (µm) (Profile Data Interval)	8.0	8.0	16.0	13.0 - 17.0	13.0 - 17.0	21.0 - 36.0	28.0 - 54.0	64.0 - 160.0	80.0 - 270.0
Repeatability Z (µm) ⁽²⁾	0.2	0.2	0.4	0.4	0.4	0.5	0.5	1.2	2.0
Clearance Distance (CD) (mm)	17.0	17.0	66.5	47.5	17.75	28.0	40.0	152	216
Measurement Range (MR) (mm)	6	6	6	25	25	55	80	295	595
Field of View (FOV) (mm)	13.0 - 14.5 (diffuse)	13.0 - 14.5 (diffuse & specular)	10.0 (diffuse)	25.0 - 32.5 (diffuse)	25.0 - 32.5 (diffuse); 25.0 (specular)	40.0 - 68.0 (diffuse)	48.0 - 100.0 (diffuse)	120.0 - 292.0 (diffuse)	154.0 - 518.0 (diffuse)
Dimensions (mm)	46x80x110	46x80x110	46x80x110	46x80x110	46x110x110	46x80x110	46x80x110	55 x 105 x 195	55 x 105 x 195
Protective Cover ⁽³⁾	-	-	-	-	-	-	-	●	●
Weight (kg)	0.65	0.65	0.65	0.65	0.65	0.65	0.65	1.48	1.48

Optical models, laser classes, and packages can be customized. Specifications stated are based on Recommended laser classes. Linearity Z and Repeatability Z may vary for other laser classes.

ALL 2500 SERIES MODELS

Interface	Gigabit Ethernet
Inputs	Differential Encoder, Laser Safety Enable, Trigger
Outputs	2x Digital output, RS-485 Serial (115 kBaud)
Factory Communication	PROFINET, Modbus, EtherNet/IP, ASCII, Gocator
Input Voltage (Power)	+24 to +48 VDC (15 Watts); Ripple ± 10%
Housing	Gasketed aluminum enclosure, IP67
Operating Temperature	0 to 40°C
Storage Temperature	-30 to 70°C
Vibration Resistance	10 to 55 Hz, 1.5 mm double amplitude in X, Y, and Z directions, 2 hours per direction
Shock Resistance	15 g, half sine wave, 11 ms, positive and negative for X, Y, and Z directions
Scanning Software	Browser-based GUI and open source SDK for configuration and real-time 3D visualization. Open source SDK, native drivers, and industrial protocols for integration with user applications, third-party image processing applications, and PLCs.

Gocator 2600 Series Laser Line Profile

MODELS	2610	2618	2629	2630	2640	2650	2670	2690
Data Points / Profile	4192	4192	4192	4192	4192	4192	4192	3700
Scan Rate (Hz) ⁽¹⁾	1100 - 9000	700 - 10,000	2500 - 9000	600 - 9000	600 - 9000	600 - 9000	600 - 9000	900 - 10,000
Linearity Z (± % of MR) ⁽²⁾	0.015	0.015	0.03	0.03	0.04	0.04	0.05	0.08
Resolution X (µm) (Profile Data Interval)	2.5	5.0 - 5.4	18 - 23	18 - 33	28 - 46	47 - 104	67 - 197	124 - 550
Repeatability Z (µm) ⁽²⁾	0.22	0.38	0.30	0.30	1.00	2.70	10.00	12.00
Clearance Distance (CD) (mm)	19.5	44.5	110	110	170	330	495	325
Measurement Range (MR) (mm)	5.0	12	45	130	190	475	1060	1550
Field of View (FOV) (mm)	10.2 - 10.8	20 - 23	71 - 93	71 - 135	105 - 198	190 - 430	272 - 817	385 - 2000
Dimensions (mm)	50 x 116 x 125	46 x 80 x 110	55 x 105 x 165	55 x 105 x 165	55 x 105 x 195	55 x 105 x 280	55 x 105 x 280	55 x 105 x 280
Protective Cover ⁽³⁾	-	-	●	●	●	●	●	●
Weight (kg)	0.9	0.65	1.34	1.34	1.48	2.12	2.12	2.12

Optical models, laser classes, and packages can be customized. Specifications stated are based on Recommended laser classes. Linearity Z and Repeatability Z may vary for other laser classes.

ALL 2600 SERIES MODELS

Interface	Gigabit Ethernet
Inputs	Differential Encoder, Laser Safety Enable, Trigger
Outputs	2x Digital output, RS-485 Serial (115 kBaud)
Factory Communication	PROFINET, Modbus, EtherNet/IP, ASCII, Gocator
Input Voltage (Power)	+24 to +48 VDC (15 Watts); Ripple ± 10%
Housing	Gasketed aluminum enclosure, IP67
Operating Temperature	0 to 50°C (Gocator 2610: 0 to 40°C)
Storage Temperature	-30 to 70°C
Vibration Resistance	10 to 55 Hz, 1.5 mm double amplitude in X, Y, and Z directions, 2 hours per direction
Shock Resistance	15 g, half sine wave, 11 ms, positive and negative for X, Y, and Z directions
Scanning Software	Browser-based GUI and open source SDK for configuration and real-time 3D visualization. Open source SDK, native drivers, and industrial protocols for integration with user applications, third-party image processing applications, and PLCs.

(1) Speed Ranges are from default configuration (full field-of-view and full measurement range) to high speed configuration (reduced field-of-view and measurement range, uniform spacing disabled, optimized data spacing and output, acceleration enabled).

(2) These results are achieved with LMI standard target and optimized sensor configuration.

(3) Protective Covers are now available for specific G2 sensor models. The cover protects the sensor's camera and laser windows from scratching caused by dust, debris, and cleaning.

LASER PROFILE SENSORS

Gocator 6300 Series

Laser Line Profile

MODELS	6310	6320
Data Points / Profile ⁽¹⁾	> 6500	> 6500
Scan Rate (Full FOV/MR) (Hz) ⁽²⁾	> 1700	> 1800
X Profile Data Interval (µm) ⁽¹⁾	< 2.1	< 4.3
Linearity Z (+/- % of MR) ⁽³⁾	0.016	0.006
Repeatability Z (µm) ⁽³⁾	0.15	0.30
Clearance Distance (CD) (mm)	18.15	57.5
Measurement Range (MR) (mm)	5.5	17
Field of View (FOV) (mm)	13.4 - 14.5	28 - 31
Dimensions (mm)	156 x 141 x 58	146 x 152 x 58
Weight (kg)	1.7	1.7

Optical models, laser classes, and packages can be customized. Specifications stated are based on Recommended laser classes. Linearity Z and Repeatability Z may vary for other laser classes.

ALL 6300 SERIES MODELS

Interface	Ethernet 2.5 Gbps
Inputs	Differential Encoder, Laser Safety Enable, Trigger
Outputs	2x Digital output, RS-485 Serial (115 kBaud)
Factory Communication	PROFINET, Modbus, EtherNet/IP, ASCII, Gocator
Input Voltage (Power)	+24 to +48 VDC (30 Watts); Ripple ± 10%
Housing	Gasketed aluminum enclosure, IP67
Operating Temperature	0 to 35°C
Storage Temperature	-30 to 70°C
Vibration Resistance	10 to 55 Hz, 1.5 mm double amplitude in X, Y, and Z directions, 2 hours per direction
Shock Resistance	15 g, half sine wave, 11 ms, positive and negative for X, Y, and Z directions
Scanning Software	Browser-based GUI and open source SDK for configuration and real-time 3D visualization. Open source SDK, native drivers, and industrial protocols for integration with user applications, third-party image processing applications, and PLCs.

(1) This specification is achieved with uniform spacing enabled

(2) Speed is calculated from default configuration (full field of view and full measurement range)

(3) These results are achieved with LMI standard target and optimized sensor configuration.

SNAPSHOT SENSORS

Gocator 3000 Series

Structured Light

MODELS	3506	3210	3520
Scan Rate (Hz)	3	4	3
Imagers (megapixels)	5	2	5
Clearance Distance (CD) (mm)	87.0	164.0	203.0
Measurement Range (MR) (mm)	25.0	110.0	150.0
Field of View (mm)	270 x 45.0 (near), 30.0 x 45.0 (far)	71.0 x 98.0 (near), 100.0 x 154.0 (far)	179.0 x 115.0 (near), 282.0 x 175.0 (far)
Repeatability Z (µm)	2.0	4.7	4.6
Resolution XY (mm)	0.020 (close end) - 0.025 (far end)	0.060 (close end) - 0.090 (far end)	0.074 (close end) - 0.121 (far end)
Dimensions (mm)	49x136x170	49x146x190	55x167x260
Weight (kg)	1.52	1.7	2.6
Light Source	Blue LED (465 nm)	Blue LED (465 nm)	Blue LED (465 nm)
Interface	Gigabit Ethernet	Gigabit Ethernet	Gigabit Ethernet
Inputs	Differential Encoder, Trigger	Differential Encoder, Trigger	Differential Encoder, Trigger
Input Voltage (Power)	+24 to +48 VDC (25 Watts); Ripple ± 10%	+24 to +48 VDC (50 Watts); Ripple ± 10%	48 VDC (50 Watts); Ripple ± 10%
Housing	Gasketed aluminum enclosure, IP67	Gasketed aluminum enclosure, IP67	Gasketed aluminum enclosure, IP67
Operating Temperature	0 to 50 °C	0 to 45 °C	0 to 40 °C
Storage Temperature	-30 to 70 °C	-30 to 70 °C	-30 to 70 °C
Outputs	2x Digital Output, RS485 Serial (115 kbaud), 1x Analog Output (4 - 20 mA)		
Vibration Resistance	10 to 55 Hz, 1.5 mm double amplitude in X, Y, and Z directions, 2 hours per direction		
Shock Resistance	15 g, half sine wave, 11 ms, positive and negative for X, Y and Z directions		

SOFTWARE AND BUILT-IN 3D MEASUREMENT TOOLS

3D Feature Tools	Openings (holes, slots), Cylinders, Studs (threaded and non-threaded), Plane
3D Volumetric Tools	Volumes, Areas, Bounding boxes, Positions (min, max, centroid), Ellipses, Orientations
Factory Communication	PROFINET, Modbus, EtherNet/IP, ASCII, Gocator
Scanning Software	Browser-based GUI and open source SDK for configuration and real-time 3D visualization. Open source SDK, native drivers, and industrial protocols for integration with user applications, third-party image processing applications, and PLCs.

PRODUCT SPECS

COAXIAL LINE CONFOCAL SENSORS

Gocator 4000 Series

Line Confocal

MODELS	4010	4011	4020	4021
Scan Rate (Hz) ⁽¹⁾	4300 - 34 000		4500 - 36 000	
Resolution X (µm) (Profile Data Interval)	1.9		2.6	
Clearance Distance (CD) (mm)	9.3 ±0.2		27.8 ±0.3	
Measurement Range (MR) (mm)	1.05		2.5	
Field of View (FOV) (mm)	3.5		5.0	
Dimensions (mm)	183 x 82 x 459		183 x 82 x 428	
Weight (kg)	10.4		9.6	
Linearity Z (± % of MR) ⁽²⁾	0.04		0.04	
Repeatability Z (µm) ⁽²⁾	0.12	0.10	0.25	0.20
Resolution Z (µm)	0.25	0.20	0.50	0.40
Max Slope Angle (°) ⁽³⁾	-45 - 85	-23 - 85	-30 - 85	-13 - 85
Application Note	In the majority of applications the 4011 and 4021 provide superior data quality, repeatability and linearity and are the recommended sensors. In applications that require additional sensitivity (shorter exposure times for higher scan speeds) or increased detection angle on highly reflective targets, the 4010 and 4020 are typically more suitable.			
ALL 4000 SERIES MODELS				
Data Points / Profile	1920			
Interface	Gigabit Ethernet			
Inputs	Differential Encoder, Trigger			
Outputs	2x Digital output			
Factory Communication	PROFINET, Modbus, EtherNet/IP, ASCII, Gocator			
Input Voltage (Power)	+24 to +48 VDC (77 Watts); Ripple ± 5%			
Housing	IP50			
Operating Temperature	15 to 35°C (above 30°C max duty cycle is 50%)			
Storage Temperature	-30 to 70°C			
Vibration Resistance	10 to 55 Hz, 1.5 mm double amplitude in X, Y, and Z directions, 2 hours per direction			
Shock Resistance	15 g, half sine wave, 11 ms, positive and negative for X, Y, and Z directions			
Scanning Software	Browser-based GUI and open source SDK for configuration and real-time 3D visualization. Open source SDK, native drivers, and industrial protocols for integration with user applications, third-party image processing applications, robots, and PLCs.			

(1) This specification is achieved with uniform spacing enabled. (2) Speed is calculated from default configuration (full field of view and full measurement range). (3) These results are achieved with LMI standard target and optimized sensor configuration.

LINE CONFOCAL SENSORS

Gocator 5500 Series

Line Confocal

MODELS	5504	5512	5516
Scan Rate (Hz) ⁽¹⁾	2100 - 39 000	4200 - 40 000	3800 - 38 000
Data Points / Profile	1792	1792	1792
Resolution X (µm) (Profile Data Interval)	2.5	6.5	9.9
Linearity Z (± % of MR)	0.03	0.07	0.04
Repeatability Z (µm) ⁽²⁾	0.05	0.2	0.25
Resolution Z (µm)	0.16	0.72	1.50
Clearance Distance (CD) (mm)	7.8	19.1	61.3
Measurement Range (MR) (mm)	1.1	3.0	5.5
Field of View (FOV) (mm)	4.3	11.6	17.0
Max. surface slope on mirror (deg)	± 15.0	± 20.0	± 13.5
Dimensions (mm)	60x190x303	91x345x419	113x358x440
Housing	IP67	IP55	IP50
Weight (kg)	5	19	21
ALL 5500 SERIES MODELS			
Interface	Gigabit Ethernet		
Inputs	Differential / Single Ended Encoder, Trigger		
Outputs	2x Digital output		
Factory Communication	PROFINET, Modbus, EtherNet/IP, ASCII, Gocator		
Input Voltage (Power)	Gocator 5512/5516: +24-48 VDC (± 5%) @ 62 W, Gocator 5504: +24-48 VDC (±5%) @ 48 W		
Operating Temperature	15 to 35°C		
Storage Temperature	-30 to 70°C		
Vibration Resistance	10 to 55 Hz, 1.5 mm double amplitude in X, Y, and Z directions, 2 hours per direction		
Shock Resistance	15 g, half sine wave, 11 ms, positive and negative for X, Y, and Z directions		
Scanning Software	Browser-based GUI and open source SDK for configuration and real-time 3D visualization. Open source SDK, native drivers, and industrial protocols for integration with user applications, third-party image processing applications, robots, and PLCs.		

(1) Speed ranges are from default configuration (full field of view and full measurement range) to high speed configuration (optimized imager readout, reduced field-of-view and measurement range). (2) These results are achieved with LMI standard target and optimized sensor configuration.

SENSOR NETWORKING

GoMax. **ORIN** / **ORIN+** SMART VISION ACCELERATOR



Powered by NVIDIA® Jetson Orin™

SUPERCHARGED DATA PROCESSING POWER.

GoMax ORIN and ORIN+ are compact, fanless, and easy-to-use smart embedded devices that enhance data processing power in real-time (including data generation, 3D measurement, and PLC/robot communication), minimizing cycle times and increasing overall inspection performance so users can achieve optimal results in heavy data processing applications.

- Easy to set up, power, and run using a web browser interface
- Dedicated edge device with no additional drivers or OS maintenance
- Deployed with Gocator snapshot and line confocal sensors to increase scan rates

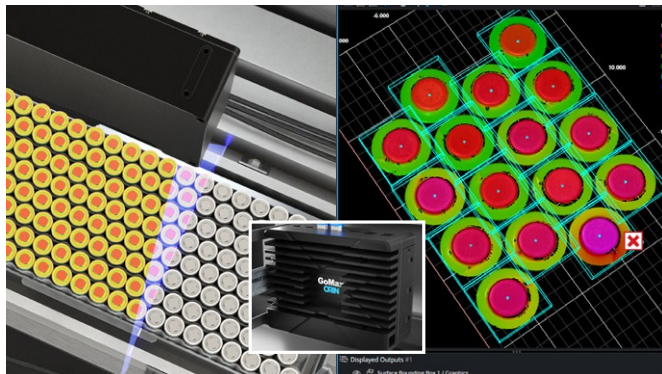

	Smart Vision Accelerator	
	GoMax ORIN	GoMax ORIN+
GPU Platform	NVIDIA Jetson Orin NX	NVIDIA Jetson AGX Orin
Dimensions (L x W x H)(mm)	180 x 136 x 75	210 x 164 x 74
Weight (kg)	2.5	2.9
Operating Temperature (°C)	-15 - 60	-20 - 55
Certifications	CE, FCC, UKCA, KCC, RoHS, Reach	CE, FCC, UKCA, KCC, RoHS, Reach
Mounting	DIN rail, wall mounting	DIN rail, wall mounting
CPU	8-core NVIDIA Arm® Cortex®-A78AE v8.2 64-bit CPU 2MB L2 + 4MB L3	8-core NVIDIA Arm® Cortex®-A78AE v8.2 64-bit CPU 2MB L2 + 4MB L3
Performance (TOPS)	157	200
GPU	Ampere, 1024 CUDA cores, 32 Tensor cores	Ampere, 1792 CUDA cores, 56 Tensor cores

Gocator laser profilers support seamless multi-sensor networking for scanning large or complex objects (i.e., with irregular surface geometry and multiple occlusions). These sensor networks are connected by LMI Master controllers.

MASTER 810 & 2410

Master 810 and 2410 network controllers make it easy to distribute power, achieve microsecond data synchronization, and provide laser safety for up to 24 sensors per Master. Designed to scale, Masters provide uplink/download ports for daisy chaining, and support differential or single-ended encoder and digital I/O.

- Synchronized within 1 µs accuracy
- All-in-one cabling
- Built-in laser safety control

BENEFITS OF MULTI-SENSOR SUPPORT

- Ideal for scanning large or complex targets
- Simple point-and-click network setup
- Built-in layout alignment and stitching for maximum ease of use
- Maintains high resolution across wide FOV

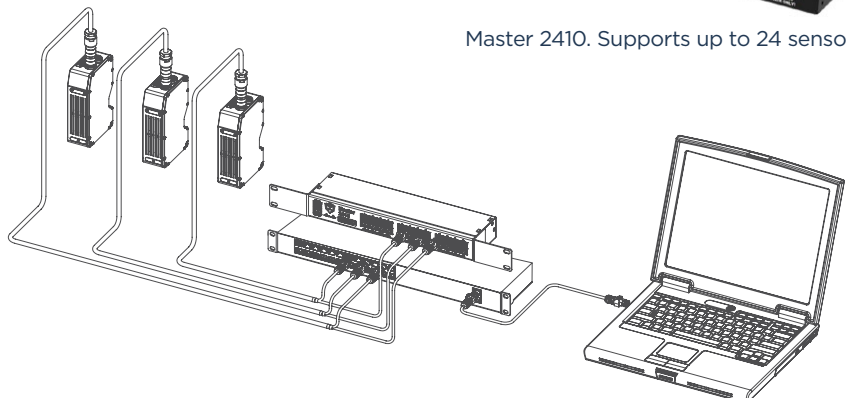

Master 810. Supports up to 8 sensors.



Master 2410. Supports up to 24 sensors.

It's Better to Be Smart.

contact@lmi3d.com | lmi3d.com



AMERICAS

LMI Technologies Inc.
Burnaby, BC, Canada

EMEAR

LMI Technologies GmbH
Teltow/Berlin, Germany

ASIA PACIFIC

LMI (Shanghai) Trading Co., Ltd.
Shanghai, China



LMI Technologies has offices worldwide. All contact information is listed at lmi3d.com/contact