



USER MANUAL

GoMax NX Smart Vision Accelerator

Firmware version: 6.1.29.3+ / 6.2.x.xx

Document revision: D

Copyright

Copyright © 2022 by LMI Technologies, Inc. All rights reserved.

Proprietary

This document, submitted in confidence, contains proprietary information which shall not be reproduced or transferred to other documents or disclosed to others or used for manufacturing or any other purpose without prior written permission of LMI Technologies Inc.

No part of this publication may be copied, photocopied, reproduced, transmitted, transcribed, or reduced to any electronic medium or machine readable form without prior written consent of LMI Technologies, Inc.

Trademarks and Restrictions

GoMax™ and Gocator™ are registered trademarks of LMI Technologies, Inc. Any other company or product names mentioned herein may be trademarks of their respective owners.

Information contained within this manual is subject to change.

Contact Information

LMI Technologies, Inc.
9200 Glenlyon Parkway
Burnaby BC V5J 5J8
Canada

Telephone: +1 604-636-1011

Fax: +1 604-516-8368

www.lmi3d.com

Table of Contents

Copyright	2
Table of Contents	3
Introduction	4
Interface	7
Safety and Maintenance	9
Electrical Safety	9
Cleaning and Maintenance	9
Environment	9
Hardware Overview	11
Protocol Support	12
Adding GoMax NX to a Sensor System	13
Connecting Power	14
Setting the IP Address	16
Discovering a GoMax NX IP Address	19
Mounting	21
Using DIN Rail Clips	21
Mounting to a Wall or Frame	21
Connecting GoMax NX to a Sensor System	23
Using GoMax NX	25
Accessing GoMax NX	26
Changing the Interface Language	28
Starting and Stopping Acceleration	29
Accessing Accelerated Sensors	31
Via a Web Browser	31
Via an SDK Application	32
Upgrading and Restoring GoMax NX	33
Monitoring the GoMax NX Health Status	35
Configuring Network Settings	37
Setting the IP Address	37
Configuring the GoMax NX Ports	37
Understanding Auto Restart	39
Understanding How GDK Tools Work with GoMax NX	40
Specifications	41
GoMax NX	42
Troubleshooting	45
Return Policy	46
Software Licenses	47
Support	50
Contact	51

Introduction

This documentation describes how to connect and use a GoMax NX unit. For information on using Gocator sensors, see the user manuals of those devices.



GoMax NX is *only* compatible with firmware 6.1 SR1 (firmware version 6.1.29.3) and later. Loading an earlier firmware version will make the device unusable.



GoMax NX firmware 6.2 is *only* necessary if you are accelerating Gocator 2600 sensors.

Notational Conventions

This documentation uses the following notational conventions:



Follow these safety guidelines to avoid potential injury or property damage.



Consider this information in order to make best use of the product.

The GoMax NX Smart Vision Accelerator is a hardware solution that accelerates any Gocator sensor to meet inline production speeds, without the need for a PC. The plug and play functionality of GoMax NX lets you quickly and easily add powerful data processing to a Gocator system, achieving faster cycle times and enhancing overall inspection performance.

GoMax NX provides this compute power thanks to its 384-core GPU and 48 Tensor cores—all in a compact, rugged case.

To accelerate sensors, GoMax NX takes over a portion of the sensor's data processing (data generation, 3D measurement, and control).

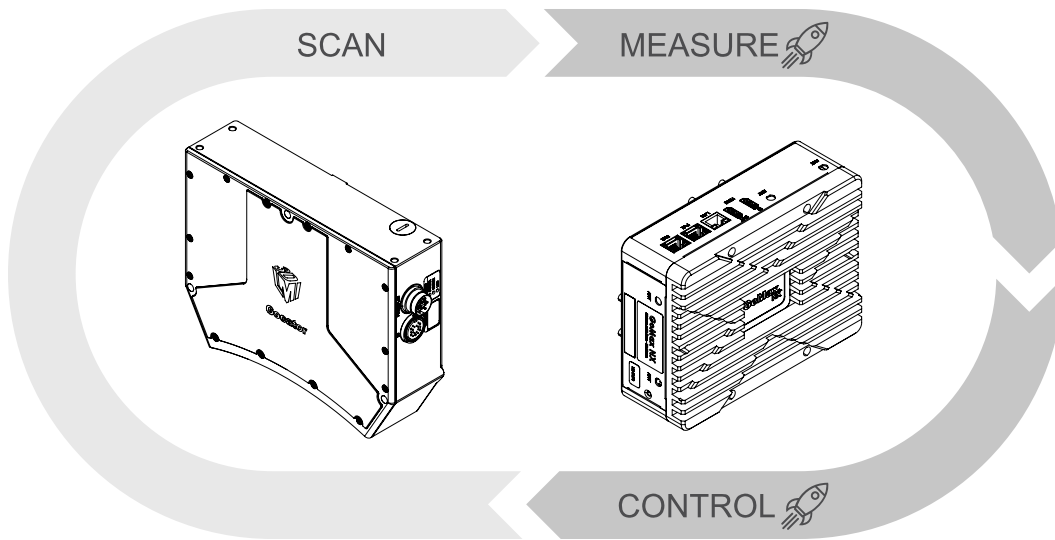

Relationship between GoMax NX (right) and a sensor (left)

GoMax NX is ideal for accelerating one or more Gocator snapshot sensors (such as Gocator 3506) or multi-sensor, buddied Gocator laser line profile sensor systems. A single GoMax NX unit can accelerate one or more sensors.

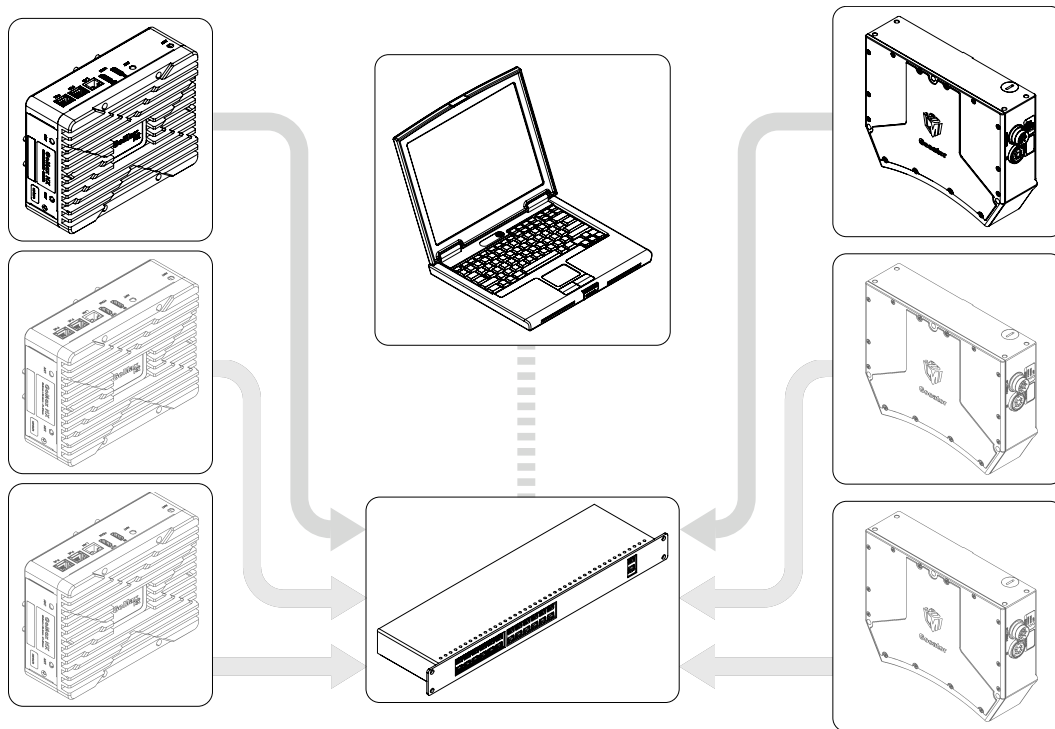

One or more GoMax NX devices accelerating one or more Gocator sensors

You can also add multiple GoMax NX units to a system, each unit accelerating one or more sensors, to scale up to faster speeds. Note however that you can't use multiple GoMax NX units to accelerate a single sensor.



GoMax NX supports digital, analog, and serial output from sensors. However, because output must be passed to the GoMax NX unit and then back to the sensor, network latency will have an impact on performance.

GoMax NX can accelerate GDK tools in custom firmware, with some limitations (for details, see *Understanding How GDK Tools Work with GoMax NX* on page 40). For information on developing GDK tools, see the reference documentation and samples provided with the library.

This documentation describes how to connect and use a GoMax NX unit. For information on using Gocator sensors, see the user manuals of those devices.



GoMax NX is *only* compatible with firmware 6.1 SR1 (firmware version 6.1.29.3) and later. Loading an earlier firmware version will make the device unusable.



GoMax NX firmware 6.2 is *only* necessary if you are accelerating Gocator 2600 sensors.

Notational Conventions

This documentation uses the following notational conventions:



Follow these safety guidelines to avoid potential injury or property damage.



Consider this information in order to make best use of the product.

The web interface on an accelerated sensor is identical to the interface on an unaccelerated sensor. The Ethernet-based output protocols (Gocator, EtherNet/IP, ASCII, and Modbus) are also identical to those found on an unaccelerated sensor, and are fully supported, with the exception of PROFINET.

Interface

You configure GoMax NX using an intuitive web interface.

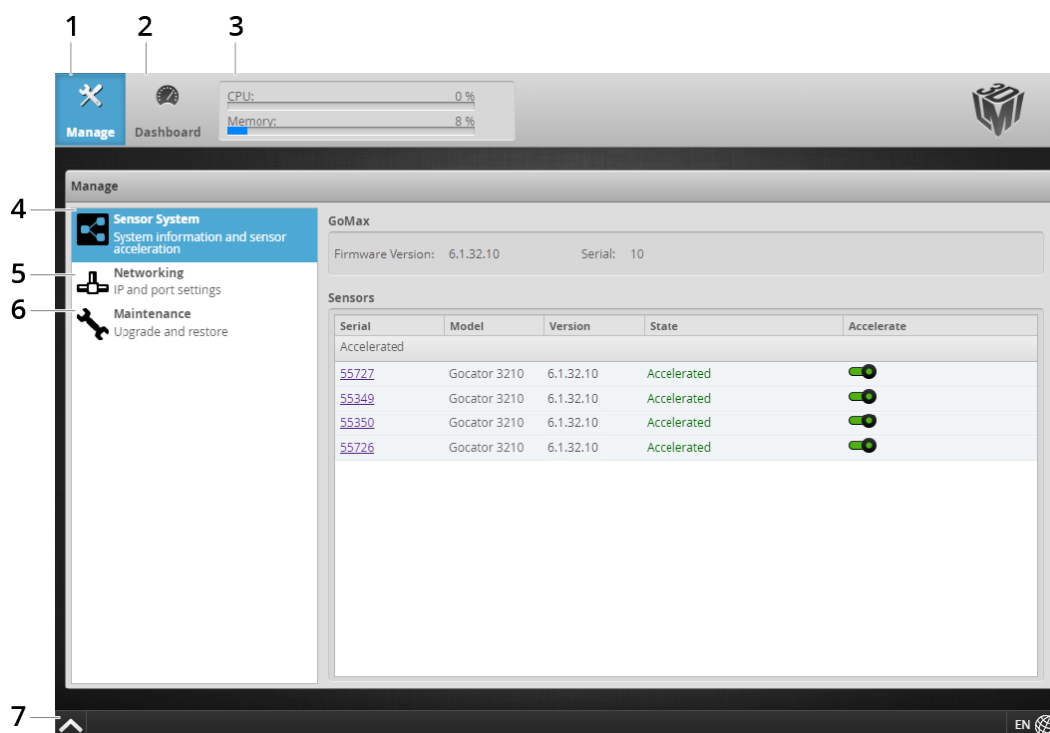

Click the icons at the top of the web interface to switch between pages, which contain a high level grouping of settings and functionalities. In panels such as the **Manage** panel shown above, click the categories to the left to switch between lower level groupings of settings.

Element	Description
1	Manage page Contains settings and controls (in the Manage panel) to start and stop acceleration, change network settings, and perform maintenance on the GoMax NX unit. For more information, see the Manage panel categories listed below.
2	Dashboard page Provides monitoring of the GoMax NX unit's health. For more information, see <i>Monitoring the GoMax NX Health Status</i> on page 35.
3	CPU Load and Speed Provides important GoMax NX metrics.
4	Sensor System category Lets you start and stop acceleration of sensors. For more information, see <i>Starting and Stopping Acceleration</i> on page 29.

	Element	Description
5	Networking category	Contains settings for configuring the network. For more information, see <i>Configuring Network Settings</i> on page 37.
6	Maintenance category	Lets you upgrade firmware and perform a factory reset of the GoMax NX unit. For more information, see <i>Upgrading and Restoring GoMax NX</i> on page 33.
7	Status bar	Displays log messages from the GoMax NX unit.

The web interface on an accelerated sensor is identical to the interface on an unaccelerated sensor. The Ethernet-based output protocols (Gocator, EtherNet/IP, ASCII, and Modbus) are also identical to those found on an unaccelerated sensor, and are fully supported, with the exception of PROFINET.

Safety and Maintenance

The following sections describe the safe use and maintenance of GoMax NX vision accelerators.



GoMax NX is *only* compatible with firmware 6.1 SR1 (firmware version 6.1.29.3) and later. Loading an earlier firmware version will make the device unusable.

Electrical Safety



Failure to follow the guidelines described in this section may result in electrical shock or equipment damage.

Sensor systems that GoMax NX is connected to should be connected to earth ground

All sensors in the system should be connected to earth ground through their housing. All sensors should be mounted on an earth grounded frame using electrically conductive hardware to ensure the housing of the sensor is connected to earth ground. Use a multi-meter to check the continuity between the sensor connector and earth ground to ensure a proper connection.

Minimize voltage potential between system ground and sensor ground

Care should be taken to minimize the voltage potential between system ground (ground reference for I/O signals) and sensor ground. This voltage potential can be determined by measuring the voltage between Analog_out- and system ground. The maximum permissible voltage potential is 12 V but should be kept below 10 V to avoid damage to the serial and encoder connections.

Use the power supply provided with the unit

If the power supply or cords get damaged, contact LMI Technologies for a replacement.

Use care when handling powered devices

Wires connecting to the GoMax NX unit should not be handled while the unit is powered. Doing so may cause electrical shock to the user or damage to the equipment.

Cleaning and Maintenance

Keep heatsink fins clear and clean

To avoid overheating of the GoMax NX unit, make sure the unit's heatsink fins are clean and clear.

Environment

Avoid installing the GoMax NX unit in hazardous environments

To ensure reliable operation and to prevent damage to the GoMax NX unit, avoid installing the unit in locations

- that are humid, dusty, or poorly ventilated;
- with a high temperature, such as places exposed to direct sunlight;
- where there are flammable or corrosive gases;
- where the unit may be directly subjected to harsh vibration or impact;
- where water, oil, or chemicals may splash onto the unit;
- where static electricity is easily generated.

Ensure that ambient conditions are within specifications

GoMax NX units are suitable for operation between -15 and 55 degrees Celcius.

Hardware Overview

The following illustrates the physical features of a GoMax NX unit.

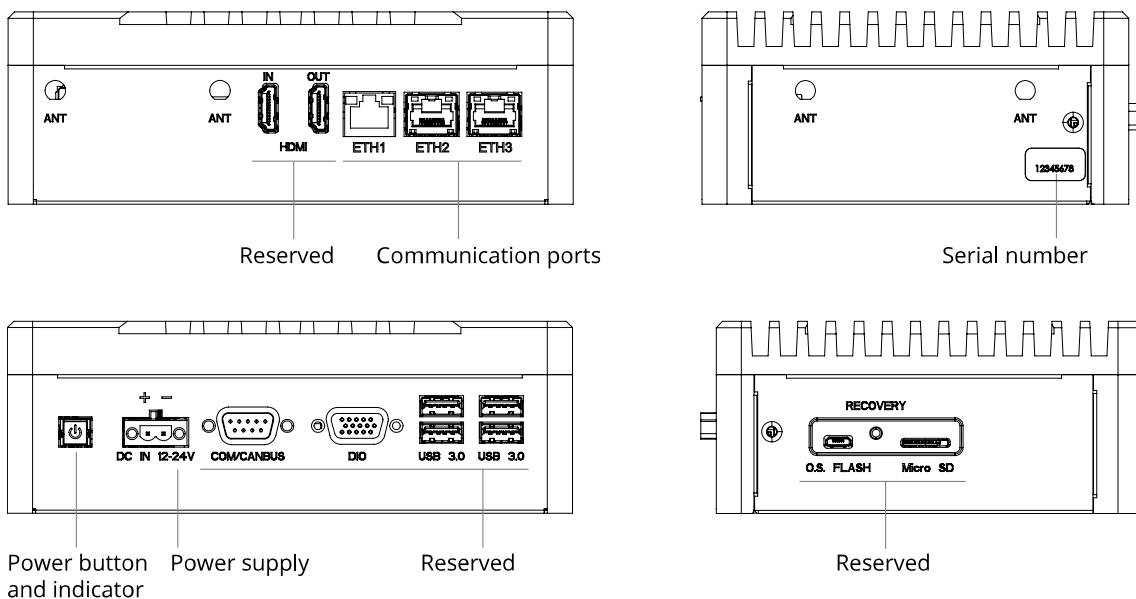

Item	Description
HDMI IN / OUT	Reserved for future use.
ETH1	Ethernet port. For direct connection to a PC for the initial configuration and to connect the GoMax unit to the sensor system via a hub. PCs and PLCs should only be connected to this Ethernet port.
ETH2	Ethernet port. Sensors can be connected to this port.
ETH3	Reserved for future use.
Power Button and Indicator	Powers the device on and off. Illuminated when power is applied (green).
DC IN 12-24V	Accepts a Phoenix connector for the provided power supply.
COM / CAN bus	Reserved for future use.
DIO	Reserved for future use.
USB 3.0	Reserved for future use.
Ant	Reserved for future use.
Serial Number	Unique sensor serial number.
OS Flash	USB C port. Reserved for future use.
Recovery button	Reserved.
Micro SD	Reserved for future use.

Protocol Support

GoMax NX supports protocols for communicating with sensors over Ethernet (TCP/IP) and serial output.



The Gocator protocol is always on and its output is always available, regardless of the output you choose. This allows simultaneous connections via an SDK application and a PLC, letting you for example archive or display scan data on a PC while controlling equipment with a PLC.



GoMax NX does not support the PROFINET protocol.

Protocols available over Ethernet

- Gocator
- Modbus
- EtherNet/IP
- ASCII

For an overview of the Ethernet ports used by sensors, see *Required Ports* in the user manual of your sensor.

Protocols available over serial

- ASCII
- Selcom

Adding GoMax NX to a Sensor System

LMI recommends adding GoMax NX to a sensor system that is already fully set up and configured. For information on setting up a sensor system, see the user manual of the sensors used in the system.

Follow the instructions in the following sections to install and perform the initial configuration of a GoMax NX unit.



Sensors you intend to accelerate using GoMax NX must be running firmware version 6.1 SR2 or higher.

Connecting Power

Power is provided by the included power supply. The plug type depends on the region in which you are using the unit.



Use *only* the provided power supply with the GoMax NX unit. Using a higher voltage power supply will damage the unit.

LMI recommends powering up the GoMax NX unit and performing the initial configuration of the unit before physically connecting it to the sensor system.

To connect power:

1. Connect the power supply connector to the unit.

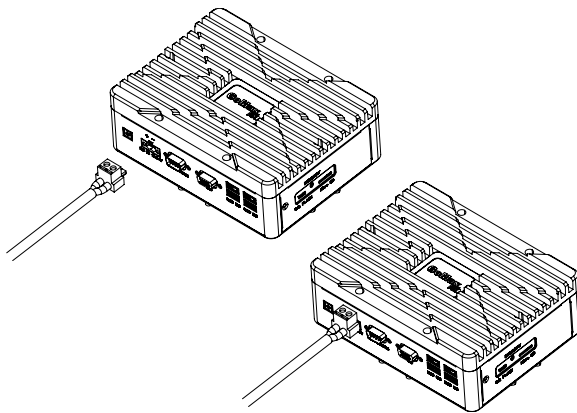

2. Plug the power adapter into an available electrical outlet.

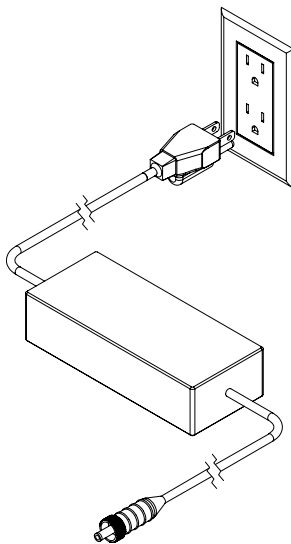

3. Press the power button.

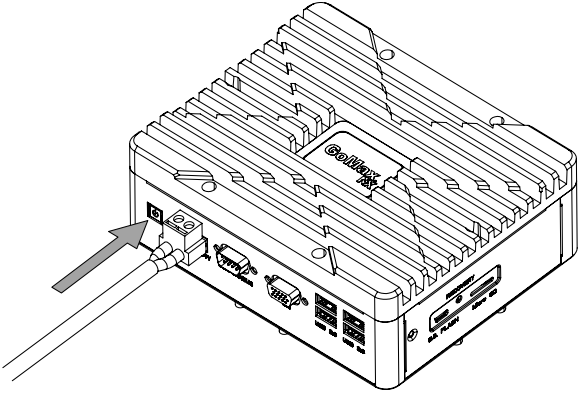

An LED indicator on the unit lights when power is applied.
The unit is ready for initial configuration (setting an IP address).

Setting the IP Address

Each GoMax NX unit and Gocator sensor on the sensor system network must have a unique IP address. By default, the IP addresses of the GoMax NX unit's Ethernet port is set to 192.168.1.6.

To set the IP address of a GoMax NX unit:

1. Using an Ethernet cable, first connect a computer directly to the ETH1 port on the GoMax NX unit.

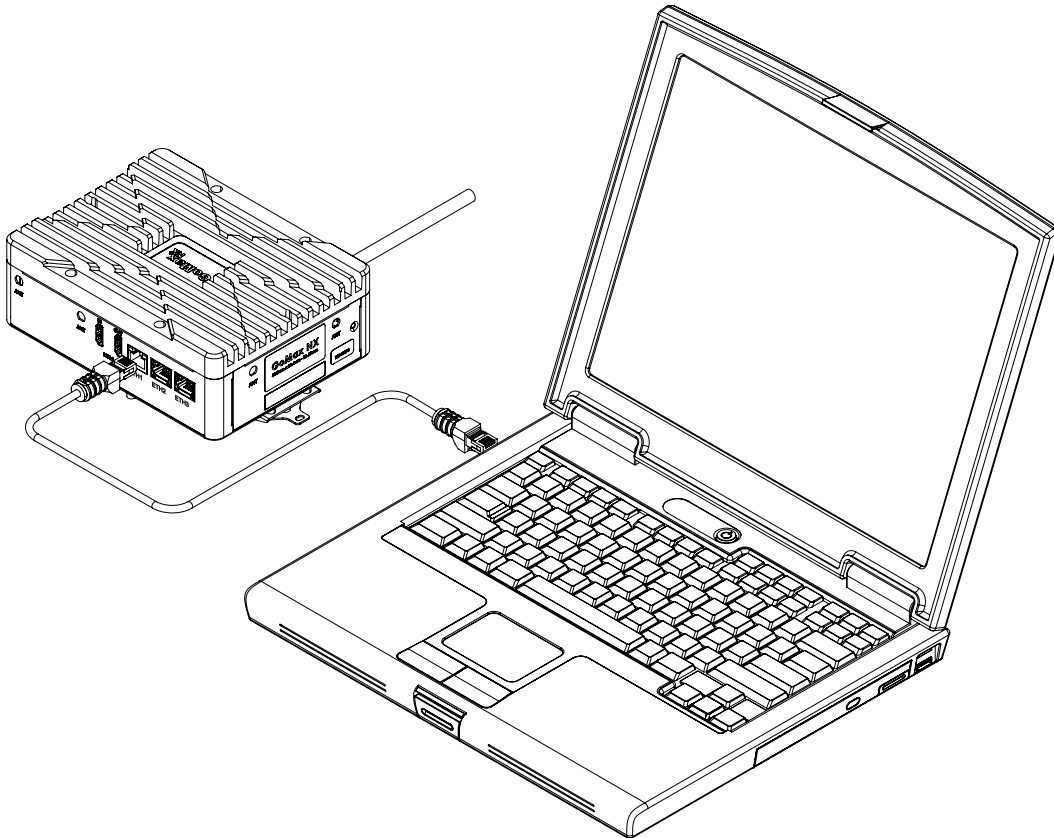

2. On the computer, launch an Internet browser and navigate to 192.168.1.6.
The GoMax NX web interface is displayed.

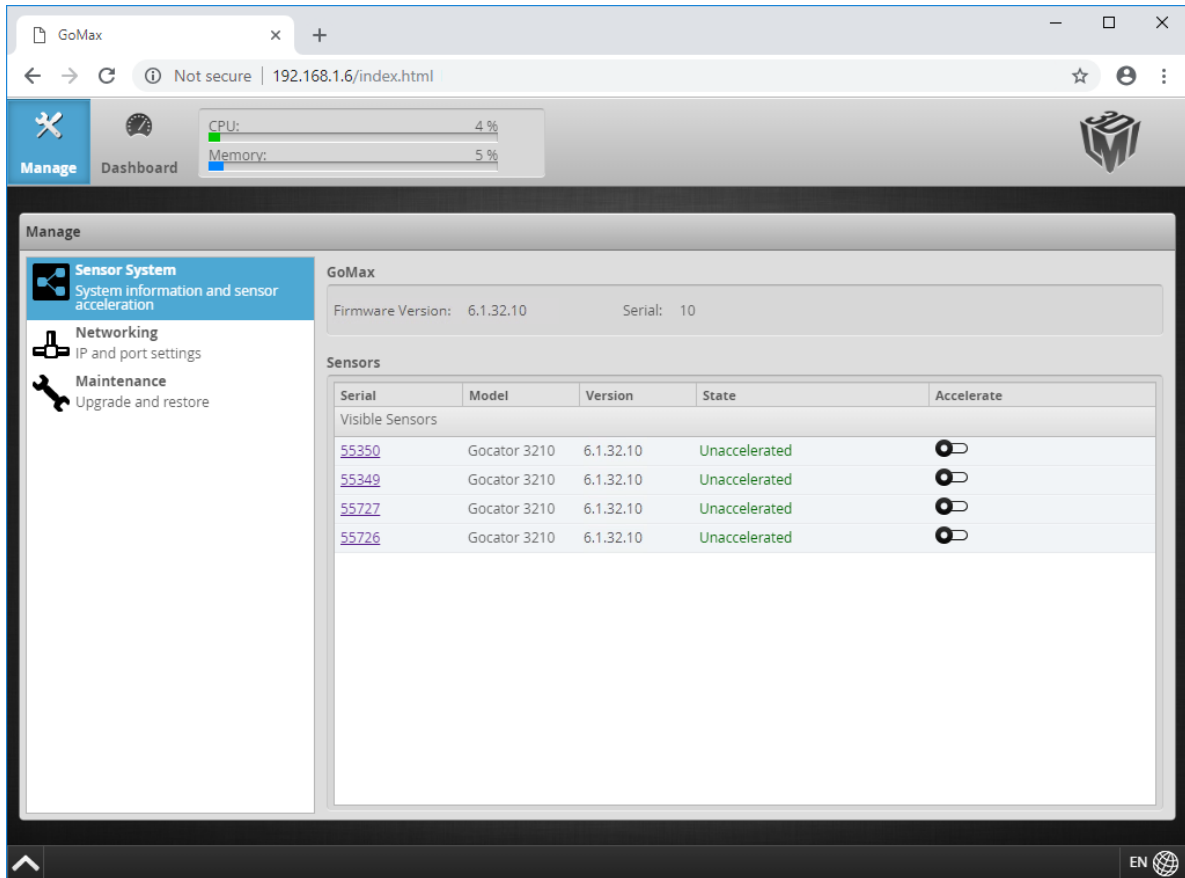

If you can't connect to the GoMax NX unit, or if you don't know what the unit's IP address is, follow the instructions in *Discovering a GoMax NX IP Address* on page 19.

3. In the **Manage** panel, click the **Networking** category.

The **Networking** category settings are displayed.

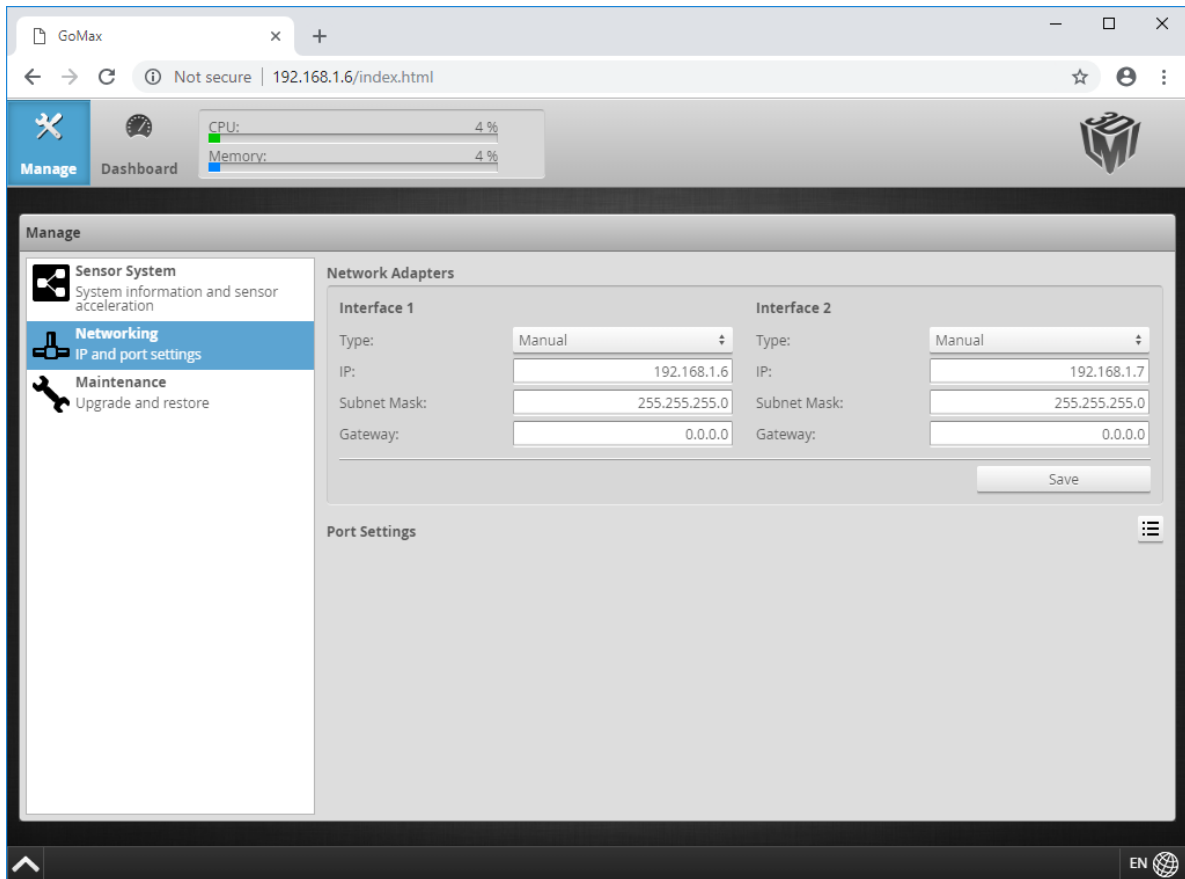

4. Under **Interface 1**, set the IP address and click **Save**.

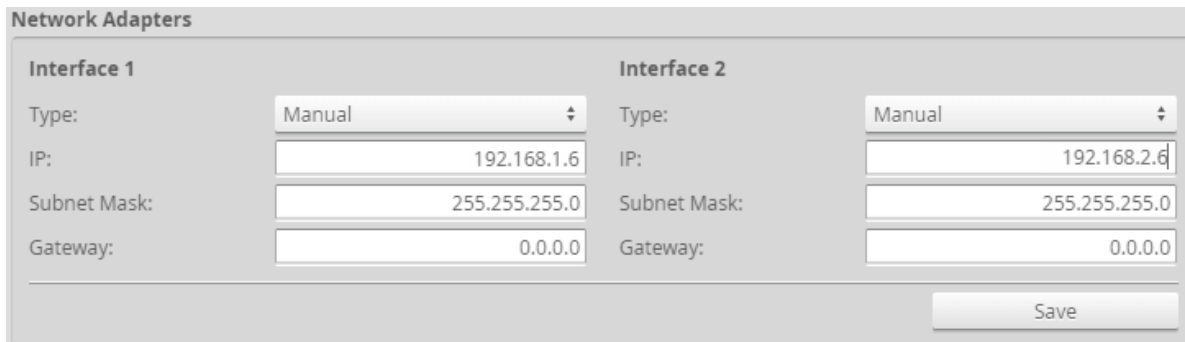

The GoMax NX unit power cycles after you confirm you want to do this. Changing network settings disconnects the GoMax NX unit and stops the acceleration of any accelerated sensors.

After the GoMax NX unit restarts, its IP addresses are changed.

5. Disconnect the laptop from the GoMax NX unit.

Discovering a GoMax NX IP Address

If you can't find or connect to a GoMax NX unit, LMI recommends using an IP scanner to find the unit on your network. LMI recommends "Free IP Scanner" for this purpose, which you can download from http://www.eusing.com/ipscan/free_ip_scanner.htm.

After downloading the software and noting where you saved it, follow the instructions below.

 Make sure the GoMax NX unit is connected to your network, or connect to it as shown in *Setting the IP Address* on page 16.

To discover the IP address of a GoMax NX unit with Free IP Scanner:

1. Launch the IP scanner by double-clicking `ipscan.exe`.

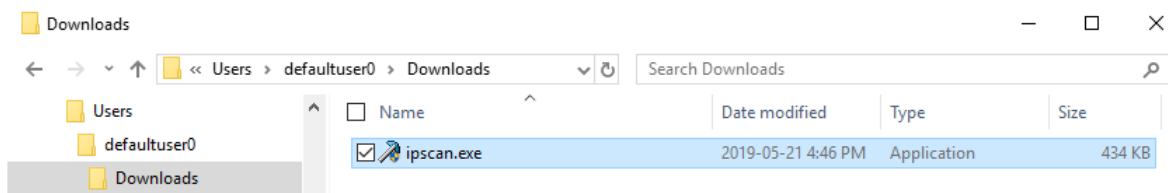

The application launches immediately. (The executable is not an installer.)

2. If User Account Control asks whether you want to allow the application to make changes to your device, click **Yes**.
3. When Free IP Scanner is running, in the dialog that displays, click **Skip**.

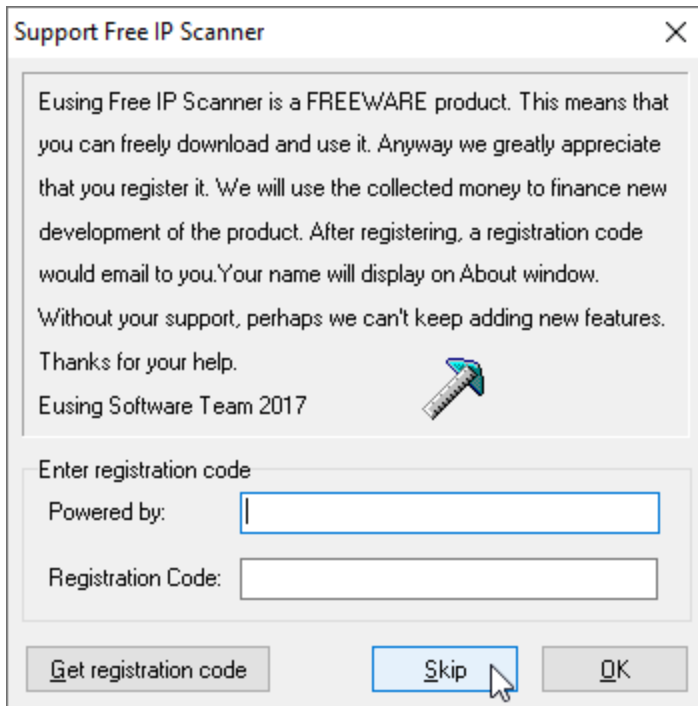

4. Set the IP range you expect the unit to be in, and then click **Start Scanning**.

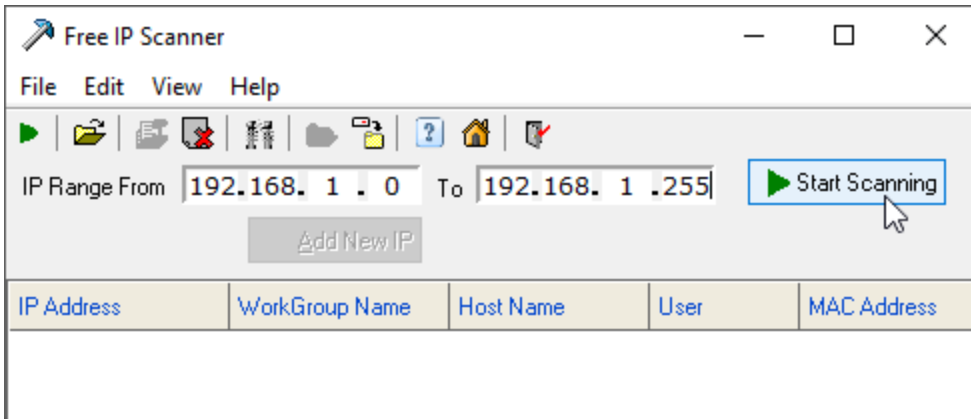

The scanner lists the devices found in the range you specify.

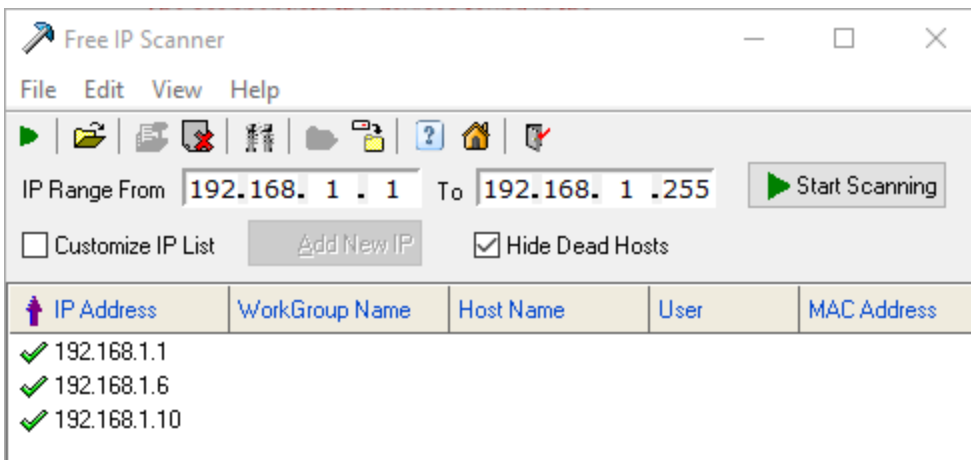

5. Make note of the GoMax NX unit's IP address in the list of discovered devices, and use that address to connect to the unit.

Mounting

You can mount GoMax NX units to a DIN rail or directly to a wall or frame using the provided mounting hardware.

For details on GoMax's dimensions and mounting holes, see *GoMax NX* on page 42.

Using DIN Rail Clips

LMI provides a DIN rail clip plate, a DIN rail clip, and M3 screws to mount GoMax NX on a DIN rail. The plate allows multiple orientations of the unit using different sets of standoffs. Attach the DIN rail clip plate to the back of the unit, and attach the DIN rail clip to the plate in the required orientation.

For dimensions with the DIN rail clip attached, see *DIN rail mount dimensions* on page 43.

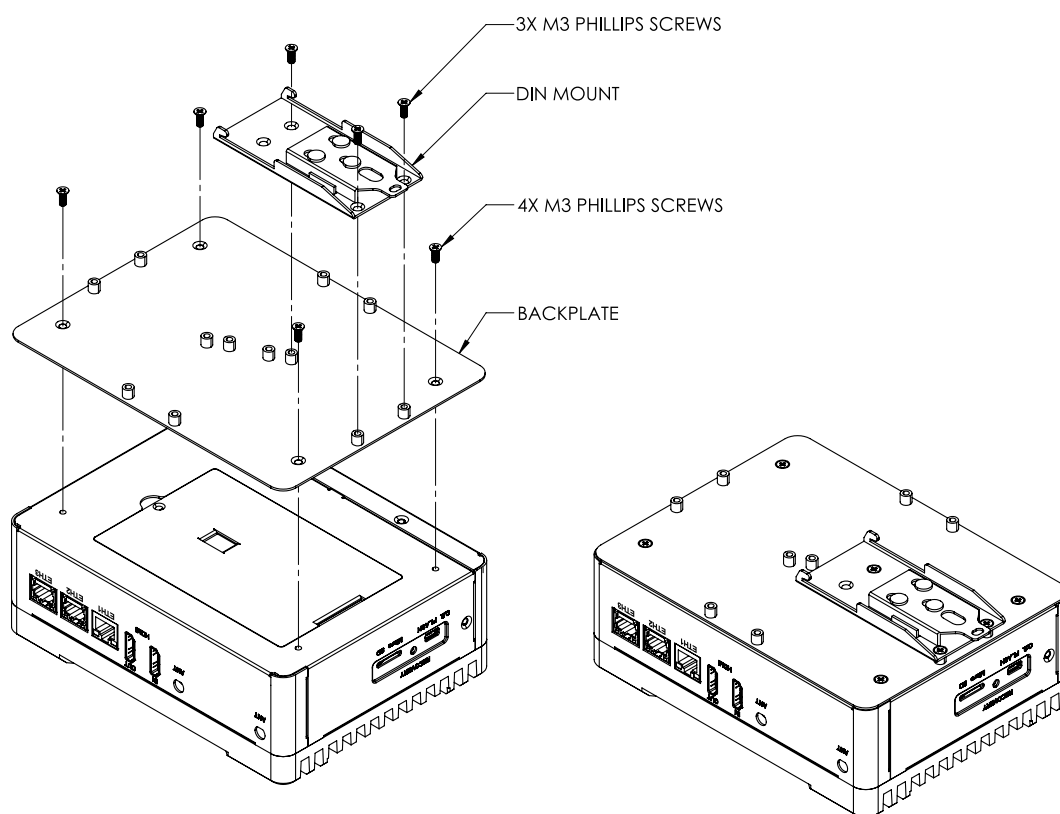

Mounting to a Wall or Frame

LMI also provides wall mount brackets to mount the GoMax NX unit directly on a wall or to a frame. To use the wall mount brackets, remove the DIN rail clip plate from the back of the unit, and attach the wall mount brackets to the back of the unit using the provided screws. Make sure that the unit is securely fastened to the wall.

For dimensions with wall mount brackets attached, see *Wall mount dimensions* on page 44.

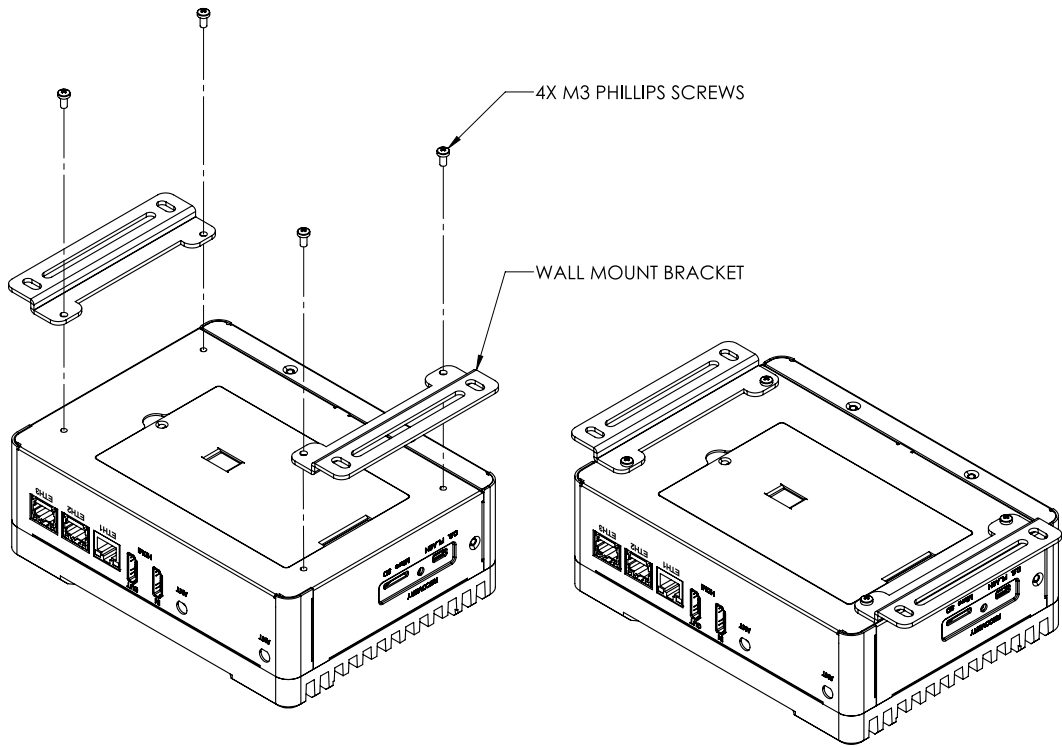

Connecting GoMax NX to a Sensor System

If you do not need to isolate the sensor from the rest of your network, you can use the following layout. In this type of layout, connect the GoMax NX unit to the switch with an Ethernet cable using the ETH1 port. Connect the sensor to the same switch.

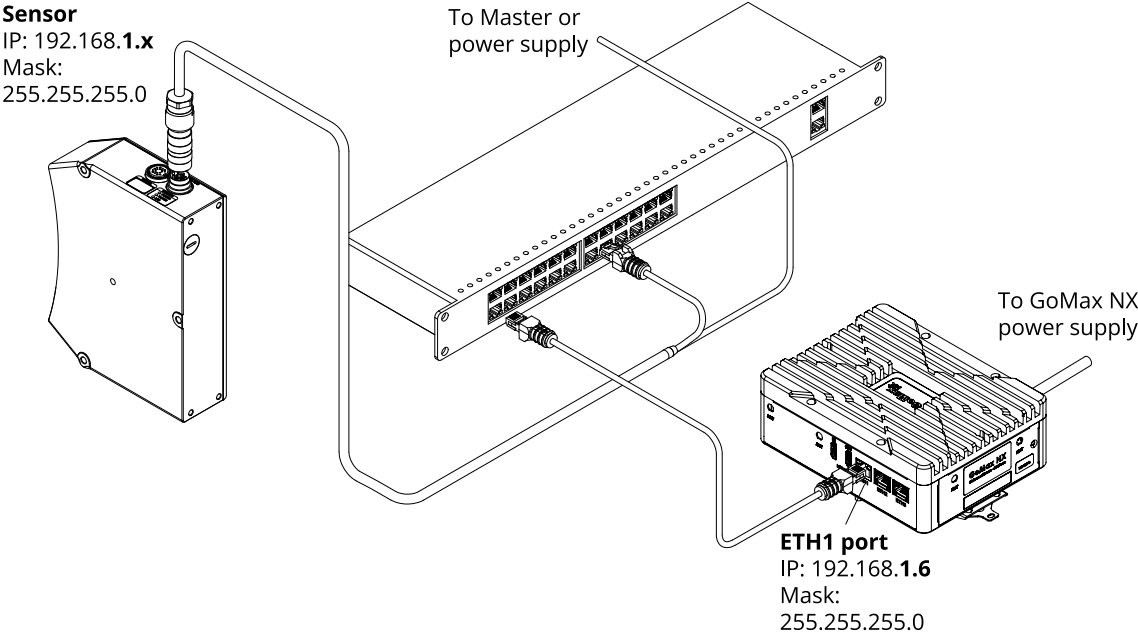

If you need to isolate a sensor from other parts of a network (for example, from PCs or PLCs), you can use a second switch. In this type of layout, *only* connect PLCs and PCs to the ETH1 port. Connect sensors to the GoMax unit's ETH2 port. Doing this lets you control visibility of the sensors over the network or adhere to network requirements or regulations. You must use a different network ID for each part of the network (sensors vs. PCs/PLCs), for example 192.168.1.x for PCs/PLCs and 192.168.2.x for sensors.

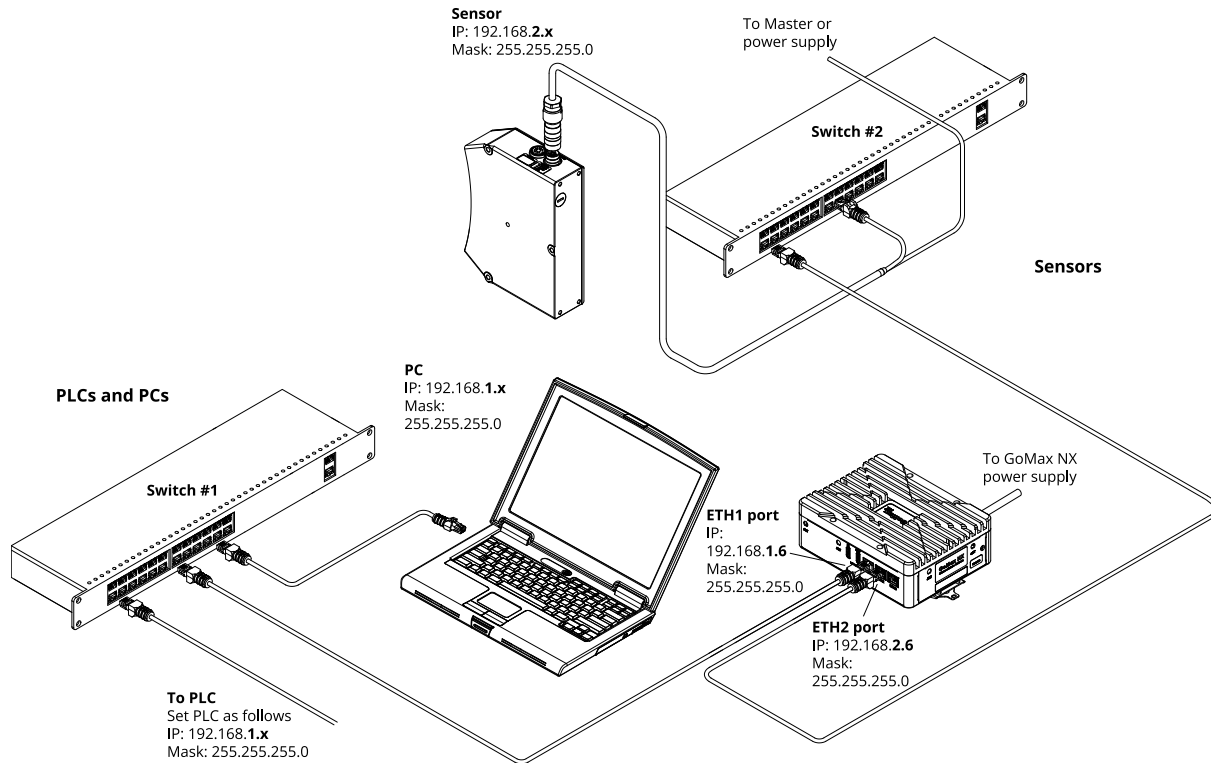

Using GoMax NX

The following sections describe how to access and configure GoMax NX using its web interface, how to start and stop sensor acceleration, and more.

Accessing GoMax NX

To access the GoMax NX vision accelerator's web interface, you can use any web browser. However, because there are currently some limitations when using the Microsoft Edge browser with the Gocator sensor web interface, you may wish to avoid this browser, to avoid inadvertently using it when configuring Gocator sensors.

 If you are unable to connect to a GoMax NX unit, see *Discovering a GoMax NX IP Address* on page 19.

To access a GoMax NX unit:

1. If the GoMax NX unit is not powered up, connect the power supply to the GoMax NX unit and turn it on. For more information, see *Connecting Power* on page 14.
2. Connect a computer to the switch using an Ethernet cable.

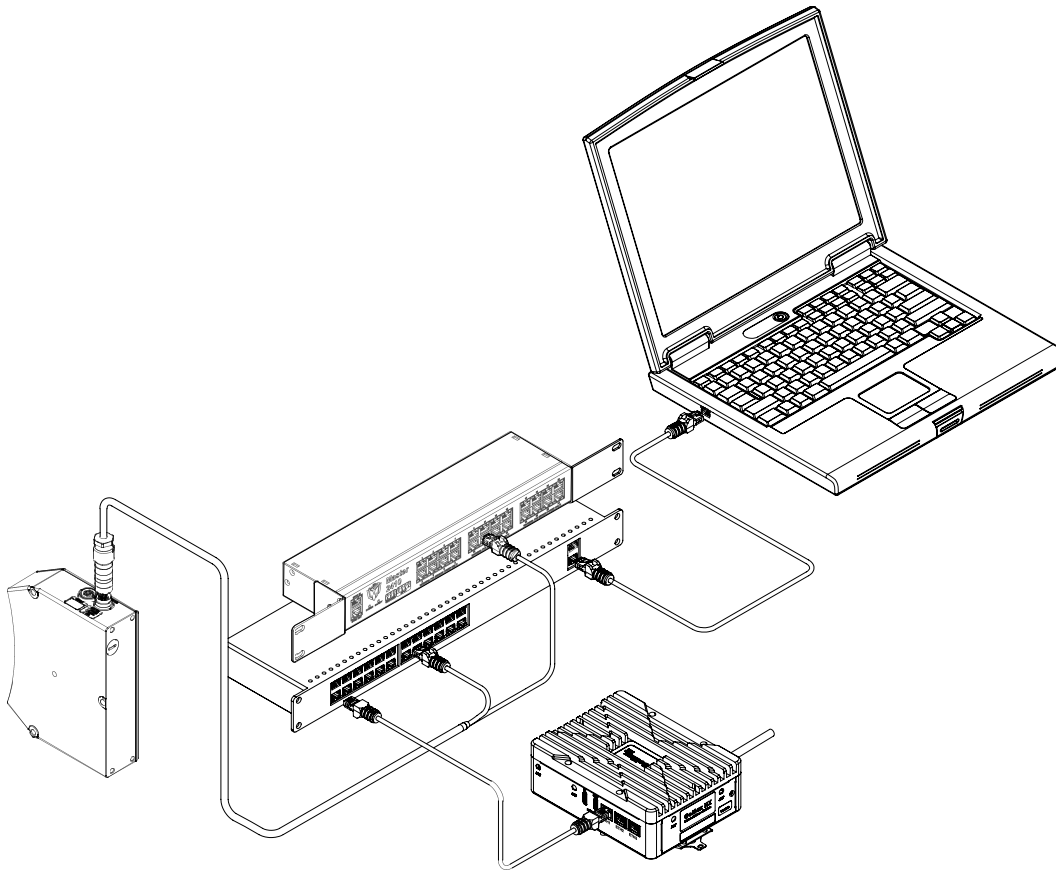

3. On the computer, using a web browser, connect to the GoMax NX web interface using the unit's IP address. The GoMax NX web interface is displayed. The **Sensor System** category is preselected in the **Manage** panel.

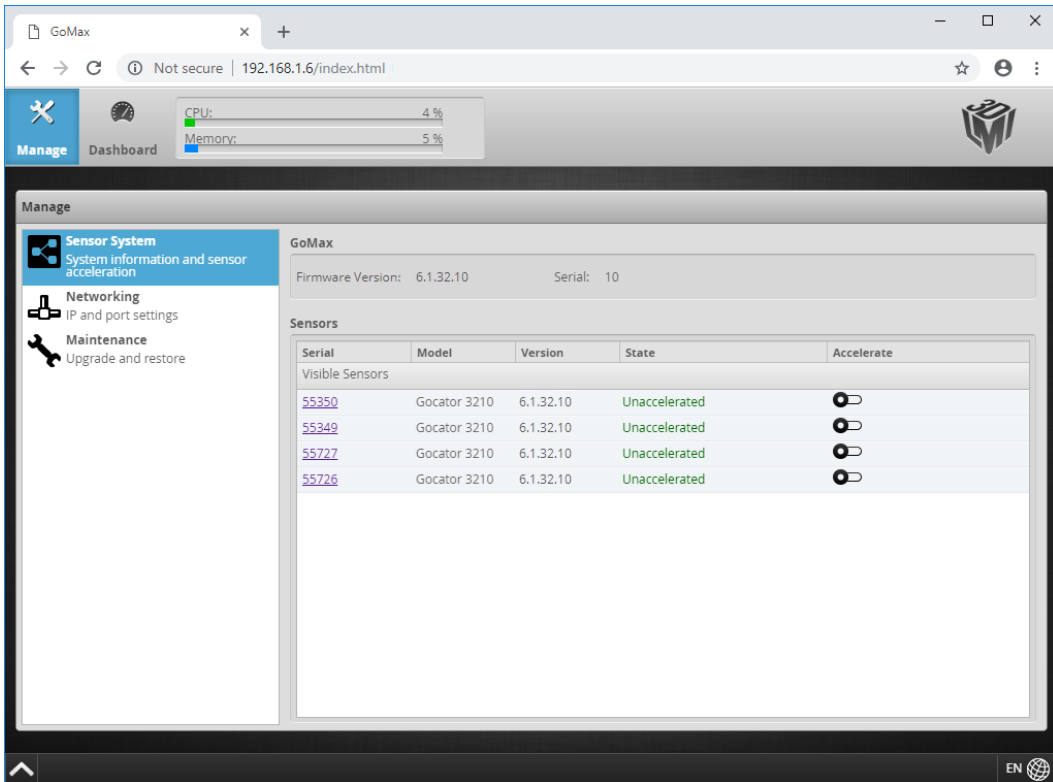

If necessary, you can set the ports GoMax NX uses for the accelerated sensors; for more information, see *Configuring Network Settings* on page 37.

You are now ready to start accelerating sensors; for more information, see *Starting and Stopping Acceleration* on page 29.

Changing the Interface Language

The language button on the right side of the status bar at the bottom of the interface lets you change the language of the interface.

To change the language:

1. Click the language button at the bottom of the web interface.



2. Choose a language from the list.



The interface reloads on the page you were working in, displaying the page using the language you chose. The sensor state is preserved.

Starting and Stopping Acceleration

After you have installed and set up a GoMax NX unit, it is ready to start accelerating one or more sensors with it.

The firmware version of the GoMax NX unit and the sensors you want to accelerate must match. Sensors whose firmware doesn't match the GoMax NX firmware are indicated by "Firmware Mismatch" in the GoMax NX interface (in the **Sensor System** category on the **Manage** page).

For information on upgrading or changing the firmware of the GoMax unit, see *Upgrading and Restoring GoMax NX* on page 33.

For information on upgrading or changing the firmware of a Gocator sensor, see the user manual of that sensor.

GoMax NX can accelerate multi-sensor (buddied) systems. However, only the Main sensor is displayed in the list of sensors that you can accelerate.

To accelerate a sensor:

1. Using a web browser, connect to the GoMax NX unit using its IP address.
2. In the **Manage** page, under **Sensors**, in the **Visible Sensors** list, click the toggle to the right of the sensor you want to accelerate.

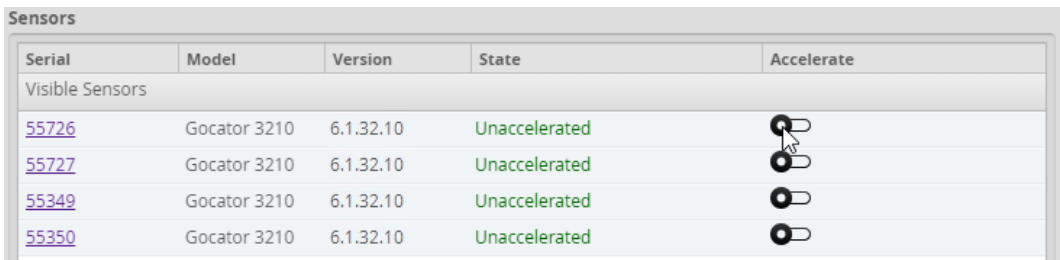

The screenshot shows a table titled "Sensors" with columns for Serial, Model, Version, State, and Accelerate. Under the "Visible Sensors" section, four rows are listed, all with a state of "Unaccelerated" and a toggle switch that is currently off.

Serial	Model	Version	State	Accelerate
Visible Sensors				
55726	Gocator 3210	6.1.32.10	Unaccelerated	<input type="checkbox"/>
55727	Gocator 3210	6.1.32.10	Unaccelerated	<input type="checkbox"/>
55349	Gocator 3210	6.1.32.10	Unaccelerated	<input type="checkbox"/>
55350	Gocator 3210	6.1.32.10	Unaccelerated	<input type="checkbox"/>

The sensor is now accelerated and appears in the **Accelerated** list.

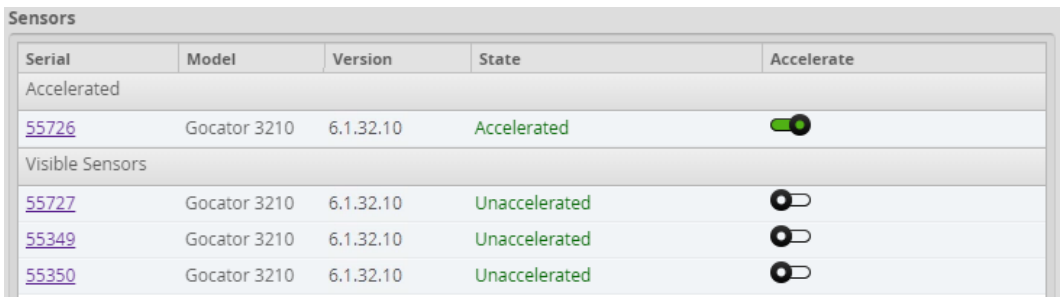



The screenshot shows the same "Sensors" table. The first row, with serial number 55726, now has a state of "Accelerated" and a toggle switch that is turned on (green). The other three sensors remain in the "Visible Sensors" section with an "Unaccelerated" state and off toggle switches.

Serial	Model	Version	State	Accelerate
Accelerated				
55726	Gocator 3210	6.1.32.10	Accelerated	<input checked="" type="checkbox"/>
Visible Sensors				
55727	Gocator 3210	6.1.32.10	Unaccelerated	<input type="checkbox"/>
55349	Gocator 3210	6.1.32.10	Unaccelerated	<input type="checkbox"/>
55350	Gocator 3210	6.1.32.10	Unaccelerated	<input type="checkbox"/>

For information on accessing the accelerated sensor, see *Accessing Accelerated Sensors* on page 31.

To stop the acceleration of a sensor:

- In the **Manage** page, under **Sensors**, in the **Accelerated** list, click the toggle to the right of the sensor for which you want to stop acceleration.

Serial	Model	Version	State	Accelerate
Accelerated				
55727	Gocator 3210	6.1.32.10	Accelerated	
55349	Gocator 3210	6.1.32.10	Accelerated	
55350	Gocator 3210	6.1.32.10	Accelerated	
55726	Gocator 3210	6.1.32.10	Accelerated	 <div data-bbox="1015 445 1172 478" style="border: 1px solid gray; padding: 2px; display: inline-block; margin-top: 5px;">Stop Acceleration</div>

The sensor is no longer accelerated. To access the sensor, use the IP address as defined in the sensor's networking settings.

Accessing Accelerated Sensors

After GoMax NX starts accelerating a sensor, you can access and configure it in two ways: via web browser and via SDK applications.

GoMax NX does not support the PROFINET protocol. For more information on PROFINET, see the Gocator user manual of your sensor.

Via a Web Browser

When you access an unaccelerated sensor via a web browser, you use the IP address of the sensor defined in the sensor's networking settings. But after a sensor has been accelerated, you can access it via the IP address of the GoMax NX unit and a port defined by GoMax NX, which are listed in the **Port Settings** section in the **Networking** category on the **Manage** page (for more information on this, see *Configuring Network Settings* on page 37). However, the easiest way to access a sensor is via the GoMax NX interface.

To access a sensor via the GoMax NX interface:

1. Using a web browser, connect to the GoMax NX unit.
2. On the Manage page, under **Sensors**, in the **Accelerated** list, click the sensor's serial number to the left.

Serial	Model	Version	State	Accelerate
Accelerated				
55726	Gocator 3210	6.1.32.10	Accelerated	
55727	Gocator 3210	6.1.32.10	Accelerated	
55349	Gocator 3210	6.1.32.10	Accelerated	
55350	Gocator 3210	6.1.32.10	Accelerated	

A page providing a link to the accelerated sensor's web interface opens in a new tab.

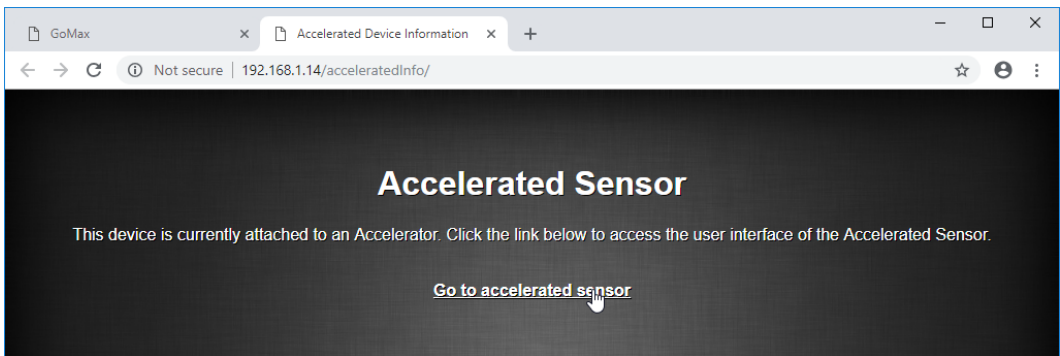

3. Click the link in the "Accelerated Device Info" page.
The web interface of the accelerated sensor is displayed.

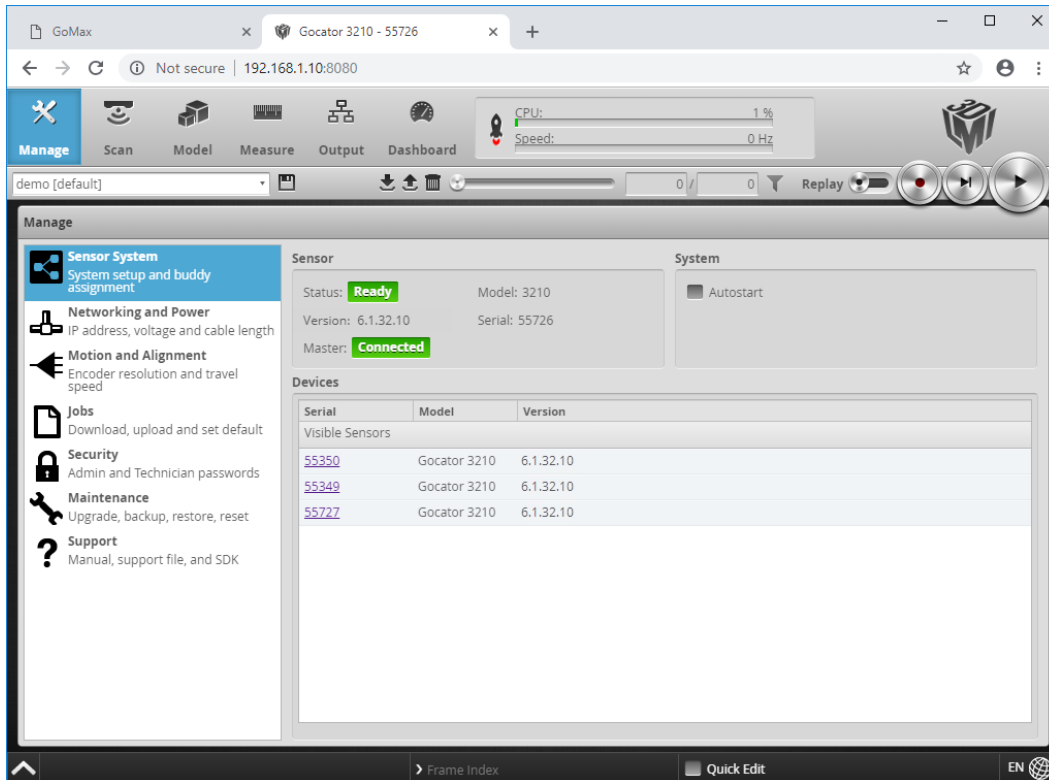

Configure the sensor as you normally would. For information on configuring a sensor, see the sensor’s user manual.

Via an SDK Application

SDK applications can access accelerated sensors in the same way as with physical sensors, controlling them and receiving messages. In SDK applications built using version 5.1 of the SDK or later, you only need the serial number of an accelerated sensor to access it. In SDK applications built using SDK versions before 5.1, you must specify the port used to access the sensor; for information on setting and viewing the port settings in GoMax NX, see *Configuring Network Settings* on page 37.

For more information on accessing accelerated sensors via the SDK, see the SDK reference documentation.

For general, introductory information on the SDK, see the sensor's user manual.

Upgrading and Restoring GoMax NX



GoMax NX is *only* compatible with firmware 6.1 SR1 (firmware version 6.1.29.3) and later. Loading an earlier firmware version will make the device unusable.



GoMax NX firmware 6.2 is *only* necessary if you are accelerating Gocator 2600 sensors.

You can upgrade the GoMax NX firmware to get the latest features or bug fixes in the **Maintenance** category on the **Manage** page. If you have developed a custom firmware containing GDK tools, you upload the firmware to the GoMax NX unit from here. You can also perform a factory restore to return the device to factory defaults from the **Maintenance** category.

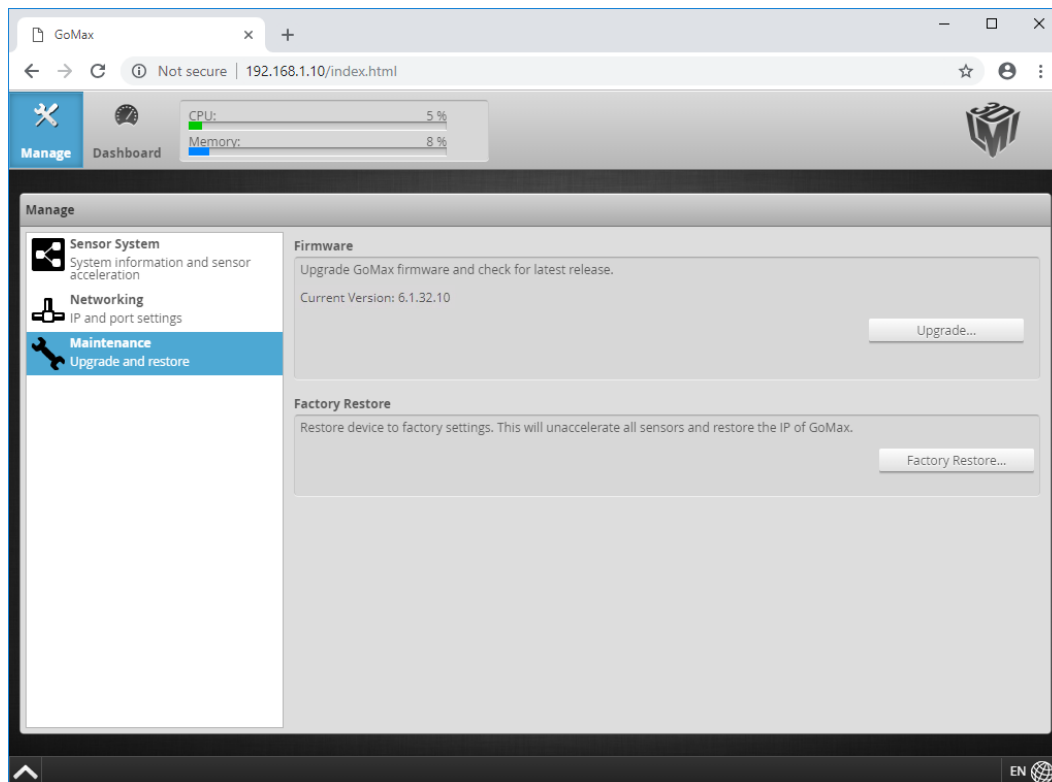

GoMax NX firmware is available from the LMI Download Center (<https://downloads.lmi3d.com/>).



The GoMax NX firmware and the sensor firmware must match in order for you to be able to accelerate a sensor.



Upgrading the GoMax NX unit or performing a factory restore stops acceleration.



To upgrade sensor firmware, you must do so from the Maintenance category of the *sensor's* web interface.



Do NOT disconnect power or the network connection from the GoMax NX unit while you are upgrading it.

To upgrade the GoMax NX firmware:

1. Go to the **Manage** page and click the **Maintenance** category.
2. Click **Upgrade...** in the **Firmware** section.

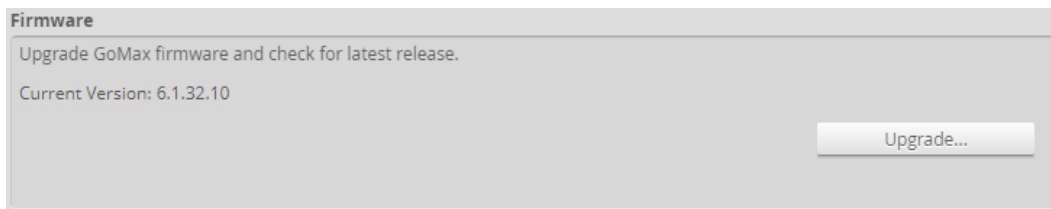

3. Locate the firmware file you downloaded from the website in the **File** dialog and then click open.
4. Wait for the upgrade to complete.
After the firmware upgrade is complete, the GoMax unit will restart.

To restore the GoMax NX unit:

1. Go to the **Manage** page and click the **Maintenance** category.
2. Click **Factory Restore...** in the **Factory Restore** section.

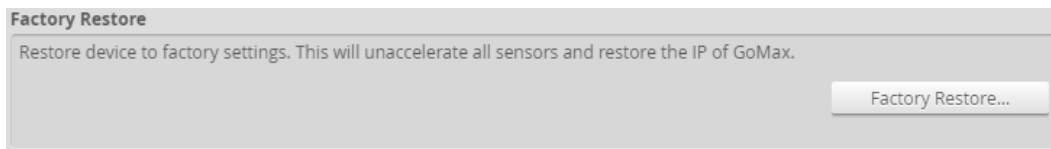

The GoMax NX unit is restored to factory defaults.

Monitoring the GoMax NX Health Status

The Dashboard page displays information related to the GoMax NX unit.

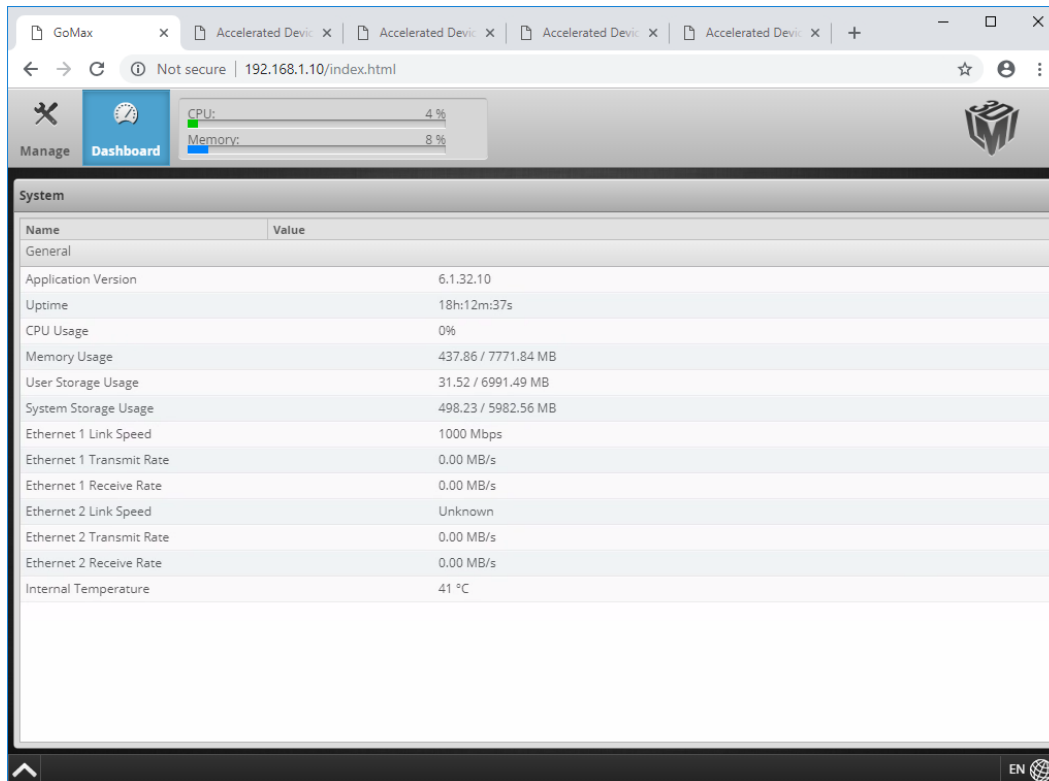

The following state and health information is available in the **System** panel on the **Dashboard** page:

Dashboard General System Values

Name	Description
Application Version	The GoMax NX firmware version.
Uptime	Length of time since the GoMax NX unit was power-cycled.
CPU Usage	The maximum usage of any of the six individual GoMax NX CPU cores. For example, this indicator will show 100% when only one of the six cores is at 100% usage.
Memory Usage	The amount of memory used by the GoMax NX unit (MB used / MB total available).
User Storage Usage	The amount of user storage used on the GoMax NX unit (MB used / MB total available).
System Storage Usage	The amount of system storage used on the GoMax NX unit (MB used / MB total available).
Ethernet {n} Link Speed	Speed of the Ethernet link between GoMax NX Ethernet {n} port and the device it is connected to (sensor or switch).
Ethernet {n} Transmit Rate	The total outgoing data rate between GoMax NX Ethernet {n} port and the device it is connected to (sensor or hub).

Name	Description
Ethernet {n} Receive Rate	The total incoming data rate between GoMax NX Ethernet {n} port and the device it is connected to (sensor or hub).
Internal Temperature	Internal temperature of the GoMax NX unit.

Configuring Network Settings

You configure network settings of GoMax NX from the **Networking** category in the **Manage** panel, on the **Manage** page. This category lets you do the following:

- Set the GoMax NX unit's IP address.
- Modify or view the ports that SDK applications should use for communication and control of the accelerated sensors in the system.

Setting the IP Address

Before configuring anything else on the GoMax NX unit, you should ensure that its IP address does not conflict with any other device (other GoMax NX units or Gocator sensors) on the sensor system. For more information on this, see *Setting the IP Address* on page 16.

Configuring the GoMax NX Ports

When a GoMax NX unit is accelerating a sensor, you access the accelerated sensor not by its internal IP address, but rather by accessing the IP address of the GoMax NX unit, on a port defined by GoMax NX. Typically, you can leave the ports at their defaults: you only need to modify the ports if non-default ports have been set

Furthermore, you can access the web interface of the accelerated sensors via the GoMax NX web interface, so there is no need to remember the accelerated sensor's IP address.

In some situations, for example, if you need to adapt ports to an existing SDK application, you may need to modify the ports. Otherwise, if you are in the process of developing an SDK application, you can consult the port assignments for each accelerated sensor by clicking the accelerated sensors in the list of accelerated sensors.

The **Port Settings** section only lets you define the port range GoMax NX can use to assign ports. GoMax NX automatically assigns the Control, Upgrade, Health, Public, and Web ports for all accelerated sensors in the defined range.

To set the port range:

1. On the **Manage** page, under the **Sensor System** category, make sure that acceleration of all sensors is stopped.

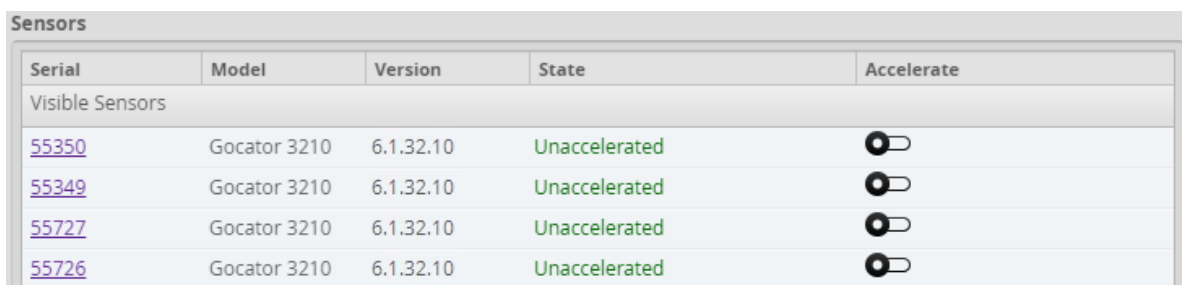

Serial	Model	Version	State	Accelerate
Visible Sensors				
55350	Gocator 3210	6.1.32.10	Unaccelerated	<input type="checkbox"/>
55349	Gocator 3210	6.1.32.10	Unaccelerated	<input type="checkbox"/>
55727	Gocator 3210	6.1.32.10	Unaccelerated	<input type="checkbox"/>
55726	Gocator 3210	6.1.32.10	Unaccelerated	<input type="checkbox"/>

You can't set the port range while GoMax NX is accelerating any sensor.

2. On the **Manage** page, under the **Networking** category, expand the **Port Settings** section.

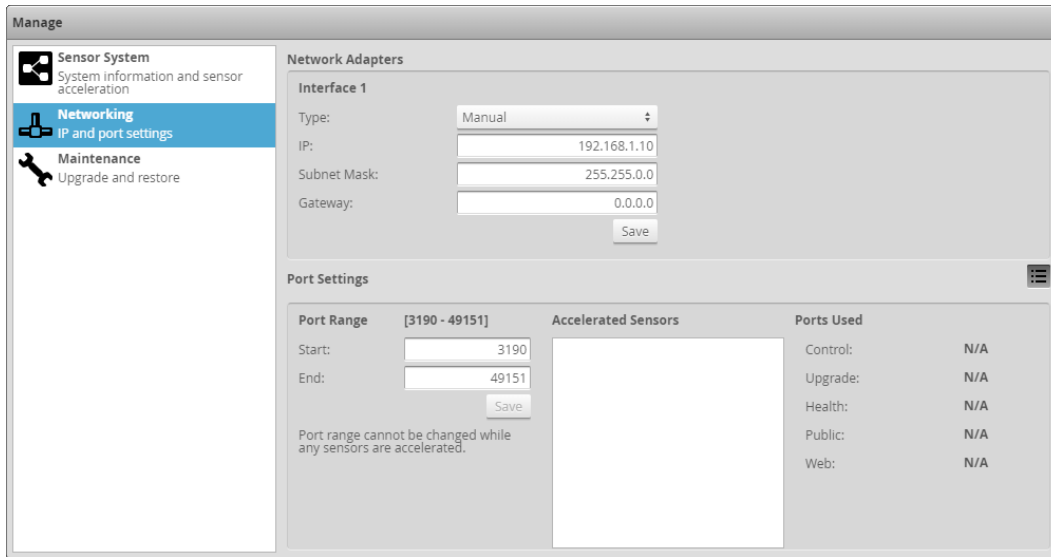

3. In the **Start** and **End** fields, type the start and end ports of the range.
4. Click **Save**.

GoMax NX will now assign ports using the defined range. Make sure to leave a range sufficiently large to accommodate all the sensors you intend to accelerate.

Understanding Auto Restart

Once a GoMax NX unit has started accelerating a sensor, it will try to re-accelerate the sensor in the following situations:

- The GoMax NX unit is power-cycled or otherwise loses power.
- If an accelerated sensor is disconnected and reconnected.

If the GoMax NX unit is accelerating multiple sensors, it will re-accelerate the sensors, one at a time, in the order that they appear in the web interface. For this reason, allow enough time for a sensor in the system to be accelerated before trying to access it.

Understanding How GDK Tools Work with GoMax NX

GoMax NX can accelerate custom firmware containing GDK-based tools. Currently however, GDK tool acceleration has the following limitations:

- The GPUs in GoMax NX are currently only supported on G3 sensors during data acquisition. This limits the degree of acceleration available.
- Third-party tools and libraries are not supported unless they compile for ARM8 and can be statically linked into the firmware.

These limitations will be removed soon, in future releases of the GoMax NX firmware.

Custom firmware is uploaded via the upgrade functionality in the GoMax NX web interface, in the same way as standard firmware is. For information on upgrading the GoMax NX firmware, see *Upgrading and Restoring GoMax NX* on page 33.

For information on building a GoMax NX firmware target, see the GDK reference documentation and samples.

Specifications

GoMax NX Specifications

NVidia Module	Jetson Xavier NX
CPU	6-core NVidia Carmel ARM v8.2
GPU	Volta GPU, 384 CUDA cores, 48 Tensor cores
Memory	8 GB LPDDR4 onboard
Storage	16 GB eMMC onboard
Supported IO	2x Ethernet (ETH1 and ETH2)
Dimensions (mm)	180 x 136 x 61.1
Weight (kg)	2.1
Operating Temperature	-15 to 55 degrees Celsius
Input Voltage (Power)	+12 to +24 VDC (15 W)
Certifications	CE, FCC class A, RoHS, Reach
Mounting	DIN rail, wall mounting



The ETH3, HDMI, and USB ports are reserved for future use.

GoMax NX

The ETH3, HDMI, and USB ports are reserved for future use.

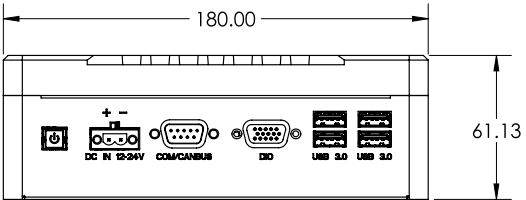
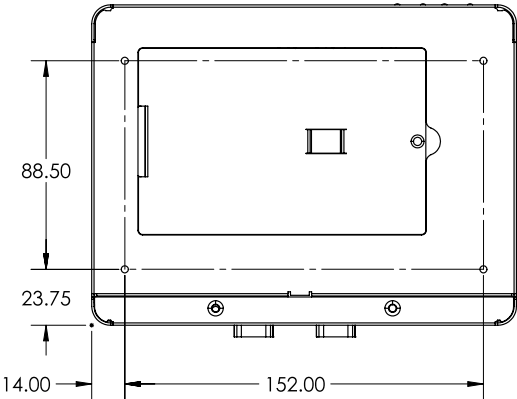
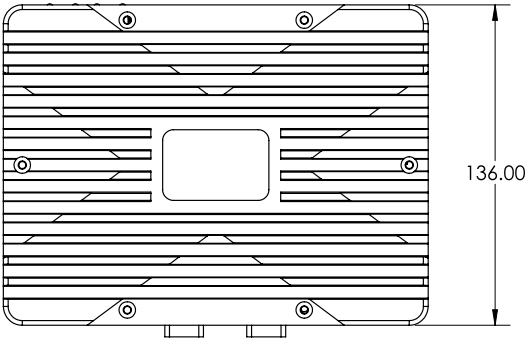

DIN rail mount dimensions

THERE ARE MULTIPLE MOUNTING POSITIONS FOR THE DIN MOUNT DEPENDING ON YOUR ANGLE REQUIREMENTS.

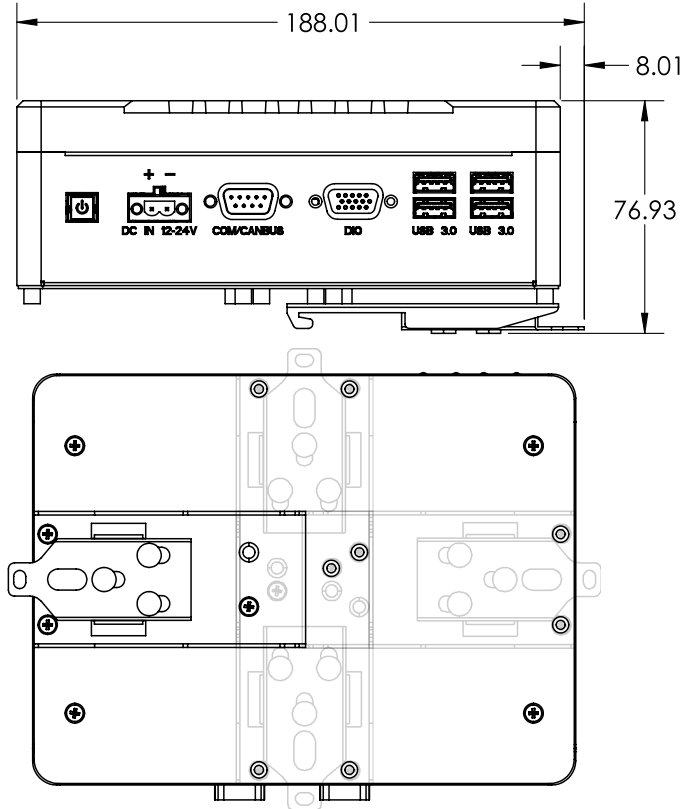

Wall mount dimensions

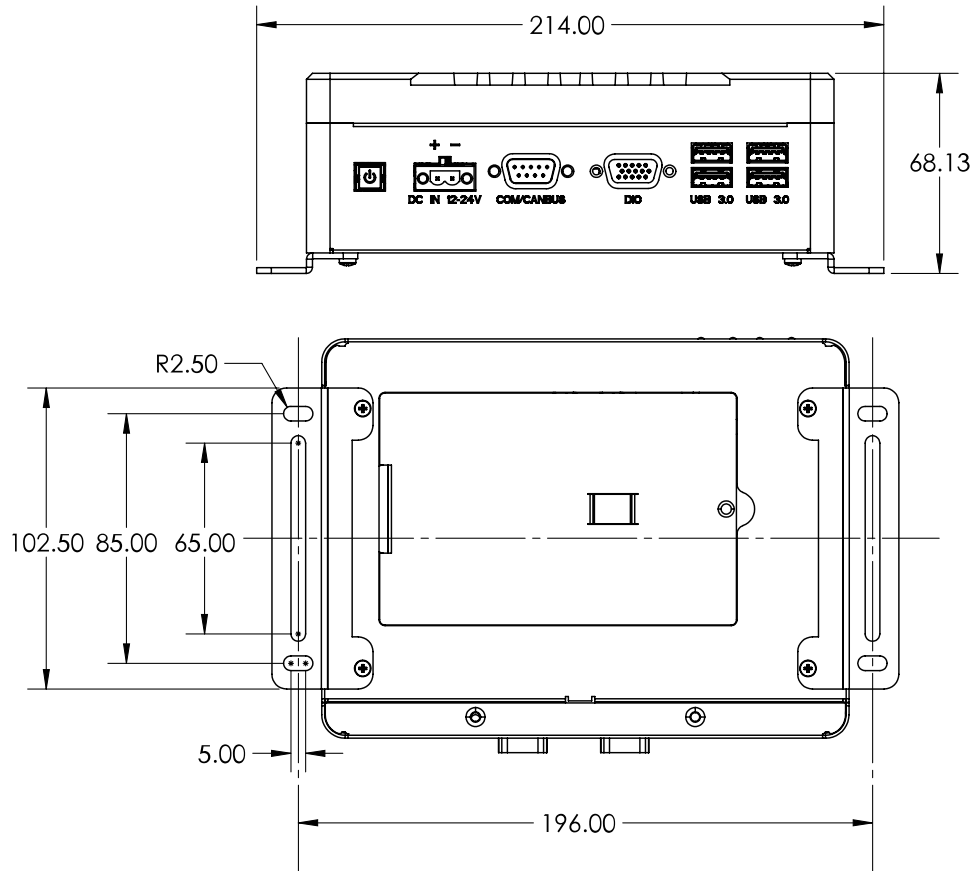

Troubleshooting

Review the guidance in this chapter if you are experiencing difficulty with a GoMax NX unit.

Mechanical/Environmental

The unit is warm.

- It is normal for a GoMax NX unit to be warm when powered on.

Connection

When attempting to connect to the GoMax NX unit with a web browser, the unit is not found (page does not load).

- Verify that the GoMax NX unit is powered on and connected to the client computer network. The power indicator LED should illuminate when it is powered.
- Check that the client computer's network settings are properly configured.
- Use IP scanning software to verify the IP address of the GoMax NX unit. For more information, see *Discovering a GoMax NX IP Address* on page 19.

Performance

The CPU level is near 100%.

- Consider reducing the speed. If you are using a time or encoder trigger source, consider reducing the speed. If you are using an external input or software trigger, consider reducing the rate at which you apply triggers.
- Consider reducing the resolution of the sensors in the system.
- Review the measurements that you have programmed and eliminate any unnecessary measurements.

Return Policy

Return Policy

Before returning the product for repair (warranty or non-warranty) a Return Material Authorization (RMA) number must be obtained from LMI. Please call LMI to obtain this RMA number.

Carefully package the GoMax unit in its original shipping materials (or equivalent) and ship the unit prepaid to your designated LMI location. Please ensure that the RMA number is clearly written on the outside of the package. Inside the return shipment, include the address you wish the shipment returned to, the name, email and telephone number of a technical contact (should we need to discuss this repair), and details of the nature of the malfunction. For non-warranty repairs, a purchase order for the repair charges must accompany the returning unit.

LMI Technologies Inc. is not responsible for damages to a unit that are the result of improper packaging or damage during transit by the courier.

Software Licenses

jQuery

Website:

<http://jquery.com/>

License:

Copyright (c) 2011 John Resig, <http://jquery.com/>

Permission is hereby granted, free of charge, to any person obtaining a copy of this software and associated documentation files (the "Software"), to deal in the Software without restriction, including without limitation the rights to use, copy, modify, merge, publish, distribute, sublicense, and/or sell copies of the Software, and to permit persons to whom the Software is furnished to do so, subject to the following conditions:

The above copyright notice and this permission notice shall be included in all copies or substantial portions of the Software.

THE SOFTWARE IS PROVIDED "AS IS", WITHOUT WARRANTY OF ANY KIND, EXPRESS OR IMPLIED, INCLUDING BUT NOT LIMITED TO THE WARRANTIES OF MERCHANTABILITY, FITNESS FOR A PARTICULAR PURPOSE AND NONINFRINGEMENT. IN NO EVENT SHALL THE AUTHORS OR COPYRIGHT HOLDERS BE LIABLE FOR ANY CLAIM, DAMAGES OR OTHER LIABILITY, WHETHER IN AN ACTION OF CONTRACT, TORT OR OTHERWISE, ARISING FROM, OUT OF OR IN CONNECTION WITH THE SOFTWARE OR THE USE OR OTHER DEALINGS IN THE SOFTWARE.

jQuery.CopyEvents

Website:

<http://brandaaron.net>

License:

Copyright (c) 2006 Brandon Aaron

Licensed under the MIT License (<http://www.opensource.org/licenses/mit-license.php>)

jQuery.history

License:

jQuery history plugin

Copyright (c) 2006 Taku Sano (Mikage Sawatari)

Licensed under the MIT License (<http://www.opensource.org/licenses/mit-license.php>)

Modified by Lincoln Cooper to add Safari support and only call the callback once during initialization for msie when no initial hash supplied. API rewrite by Lauris Bukis-Haberkorns

jQuery.mouseWheel

Website:

<http://brandonaron.net>

License:

Copyright (c) 2010 Brandon Aaron

Licensed under the MIT License (<http://www.opensource.org/licenses/mit-license.php>)

jQuery.scaling

Website:

<http://eric.garside.name>

License:

Scaling 1.0 - Scale any page element

Copyright (c) 2009 Eric Garside

Licensed under the MIT License (<http://www.opensource.org/licenses/mit-license.php>)

jQuery.scrollFollow

Website:

<http://kitchen.net-perspective.com/>

License:

Copyright (c) 2008 Net Perspective

Licensed under the MIT License (<http://www.opensource.org/licenses/mit-license.php>)

node

Website:

<https://github.com/nodejs/node>

License:

<https://github.com/nodejs/node/blob/master/LICENSE>

Support

For help with a component or product, please submit an online support ticket using LMI's [Help Desk](http://support.lmi3d.com/newticket.php) at <http://support.lmi3d.com/newticket.php>.

If you are unable to use the Help Desk or prefer to contact LMI by phone or email, use the contact information below.



Response times for phone or email support requests are longer than requests submitted through the Help Desk.

North America

Phone	+1 604 636 1011
Fax	+1 604 516 8368
Email	support@lmi3d.com

Europe

Phone	+31 45 850 7000
Fax	+31 45 574 2500
Email	support@lmi3d.com

For more information on safety and laser classifications, please contact:

*U.S. Food and Drug Administration
Center for Devices and Radiological Health
WO66-G609
10903 New Hampshire Avenue
Silver Spring MD 20993-0002
USA*

Contact

Americas	EMEAR	ASIA PACIFIC
LMI Technologies (Head Office) Burnaby, Canada +1 604 636 1011	LMI Technologies GmbH Berlin, Germany +49 (0)3328 9360 0	LMI (Shanghai) Trading Co., Ltd. Shanghai, China +86 21 5441 0711

LMI Technologies has sales offices and distributors worldwide. All contact information is listed at lmi3d.com/contact/locations.