



USER'S MANUAL

Gocator 2342-3B-12
Version 3.5.2.130 Revision: A

Proprietary

This document, submitted in confidence, contains proprietary information which shall not be reproduced or transferred to other documents or disclosed to others or used for manufacturing or any other purpose without prior written permission of LMI Technologies Inc.

No part of this publication may be copied, photocopied, reproduced, transmitted, transcribed, or reduced to any electronic medium or machine readable form without prior written consent of LMI Technologies, Inc.

Trademarks and Restrictions

Gocator™ is a registered trademark of LMI Technologies, Inc. Any other company or product names mentioned herein may be trademarks of their respective owners. Information contained within this manual is subject to change.

This product is designated for use solely as a component and as such it does not comply with the standards relating to laser products specified in U.S. FDA CFR Title 21 Part 1040.

Contact Information

For more information, please contact LMI Technologies.

LMI Technologies, Inc.
1673 Cliveden Ave.
Delta,
BC V3M 6V5 Canada

Telephone: +1 604 636 1011
Facsimile: +1 604 516 8368

www.lmi3D.com

Table of Contents

1	Introduction	4
2	Sensor Setup	5
2.1	Coordinate Definition.....	5
2.2	RoLine Operation Mode	5
2.3	Tracking Window.....	6
2.4	Raw Profile Ethernet Output.....	7
2.5	Bridge Value Calculation	7
2.5.1	Selcom Serial.....	10
2.6	Exposure Pulse	12
3	Gocator Protocol	14
3.1	Modes	14
3.2	Configuration Files	14
3.3	Data Result	14
4	Summary of Differences.....	15
5	Hardware	17
5.1	Selcom Serial Interface	17
5.2	Field of View	18
5.3	Envelope.....	18
5.4	Dimension.....	18

Introduction

1 Introduction

This document provides supplementary information for using the Gocator 2342-3B-12 (LMI's next generation RoLine).

Readers should refer to the Gocator User's Manual and Quick Start Guide for setup and safety precautions required by Gocator. Cited sections from the User's Manual are shown in *italics*.

Gocator Protocol

2 Sensor Setup

The Gocator 2342-3B-12 is loaded with a default sensor configuration that makes it behave similar to a RoLine 1130/1145 sensor, delivering bridge value over Selcom serial. Users can use the Gocator's web-based user interface to enable raw profiles over Ethernet and enable exposure pulse to synchronize with external device.

The selected settings can be saved in the sensor as a configuration file which can then be automatically loaded when the sensor is powered on.

Section 4 summarizes the differences between the RoLine 11xx and the Gocator. The following sections describe how to configure the Gocator to support RoLine behavior.

2.1 Coordinate Definition

The Z-axis in the Gocator's coordinate system is slightly different to that of the RoLine. In the Gocator, the origin is in the middle of the range, also called the standoff distance. Z is positive when profile data is closer to the sensor than the standoff distance. In the RoLine, Z is always positive, and increases as profile data is further away from the sensor.

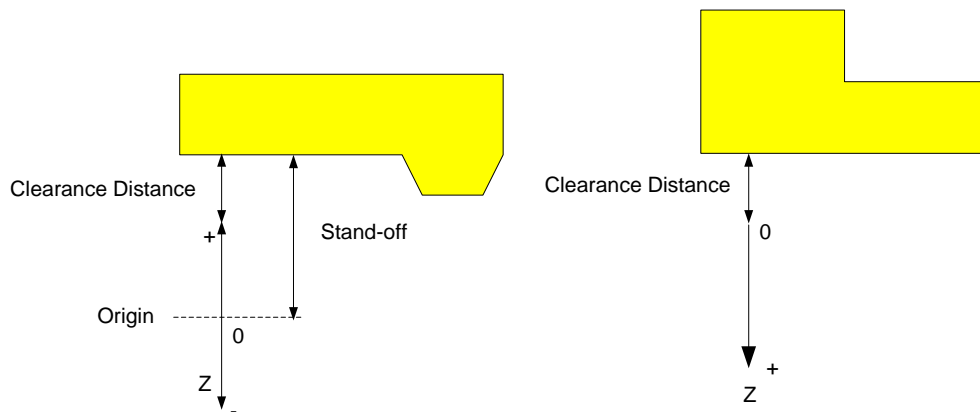

Z-axis (Left is Gocator, Right is RoLine)

With the Gocator, the user can adjust the origin by performing an alignment calibration. Refer to the Gocator User's Manual for more detail.

2.2 RoLine Operation Mode

The Gocator 2342-3B-12 supports two operation modes: Video or RoLine mode. Video mode displays images collected from the Gocator's imager. Video mode can be used to fine tune exposure settings or observe the influence of ambient light on collected data.

The video images cover the sensor's full active window measurement range. In the RoLine 11xx, the video image only covers the smaller tracking window (see the next section for more detail).

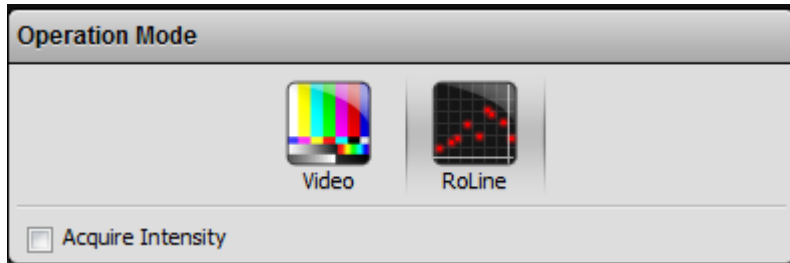

In RoLine mode, the sensor profiles the surface, calculates a bridge value, and outputs the result over Selcom Serial. The user can alternatively remove the bridge value measurement and output raw profiles over Ethernet.

2.3 Tracking Window

The default configuration enables the Gocator tracking window to optimize the sensor's speed while scanning a large measurement range. The tracking window dynamically switches between two states: searching and tracking. In the searching state, the sensor uses a larger *search* window to locate the laser line. After finding the laser, the sensor enters a tracking state, where it will dynamically position a smaller *tracking* window to follow the laser. If the tracking window loses the laser line, the algorithm switches back to the searching state in order to re-acquire the laser.

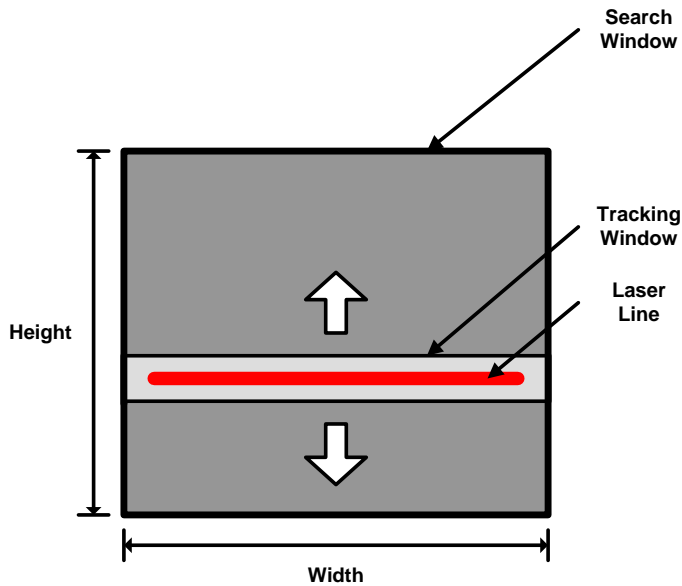

Searching is slower than tracking because the search window covers a larger area of the imager. The user can configure the searching and tracking window size in the Gocator web interface. Refer to the Tracking Window section in the Gocator User's Manual.

2.4 Raw Profile Ethernet Output

To send raw profile data at full rate over Ethernet:

1. Remove bridge value measurement in the Measurement page. The bridge value calculation should not run concurrently with raw Ethernet output, as this may exhaust the CPU at high frame rates.
2. Select Raw Profile “Main” in the Ethernet output panel and disable all other outputs in the Output page.

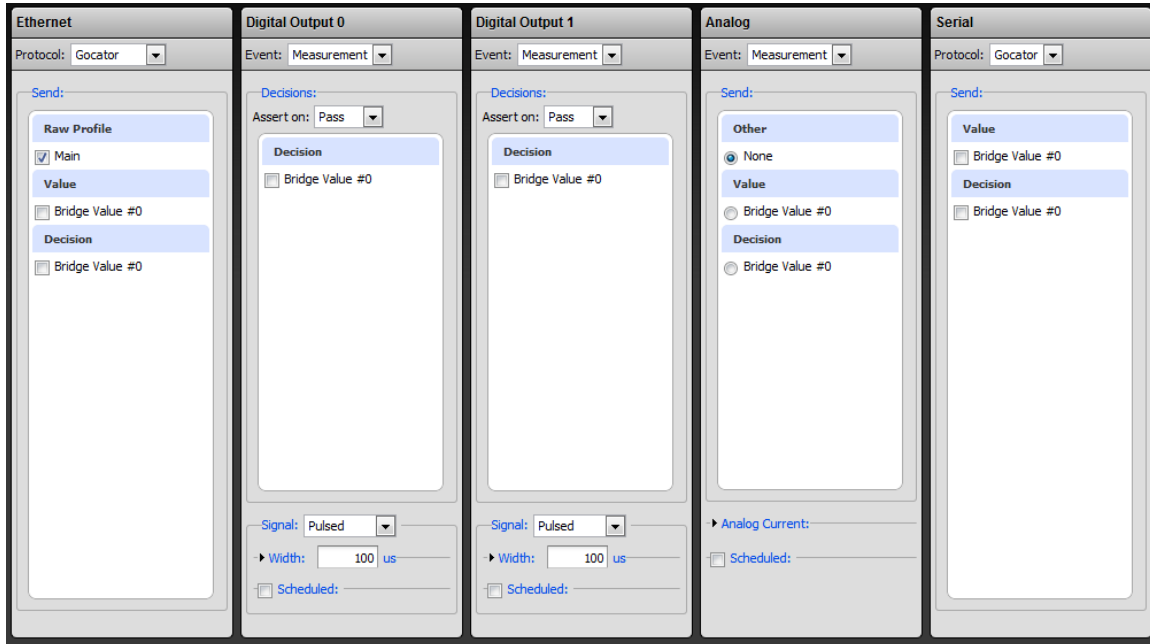

2.5 Bridge Value Calculation

The Gocator can output a single, processed range value known as the “bridge value”. The bridging algorithm, in its essence, is a filtered average of a laser line profile.

The algorithm has the following characteristics:

- Accept a profile only if it has enough valid data points.
- Eliminate the influence of outliers on the roughness calculation.
- Compensate for the tilt of the vehicle caused by vehicle movement and rutting.

The bridging algorithm uses the center of the profile as the rotational point for tilt compensation.



Raw laser line profile



Tilt corrected laser profile

In order to filter outliers, the tilt-corrected profile points are sorted from highest to lowest range into a histogram. The user can adjust two algorithm parameters, Window Skip and Window Size (see table below) to select the profile points to be averaged and output as the Bridged value. By adjusting these parameters the user can remove unwanted features (i.e. rocks, cracks, tining valleys, etc) to get an accurate representation of the road roughness.

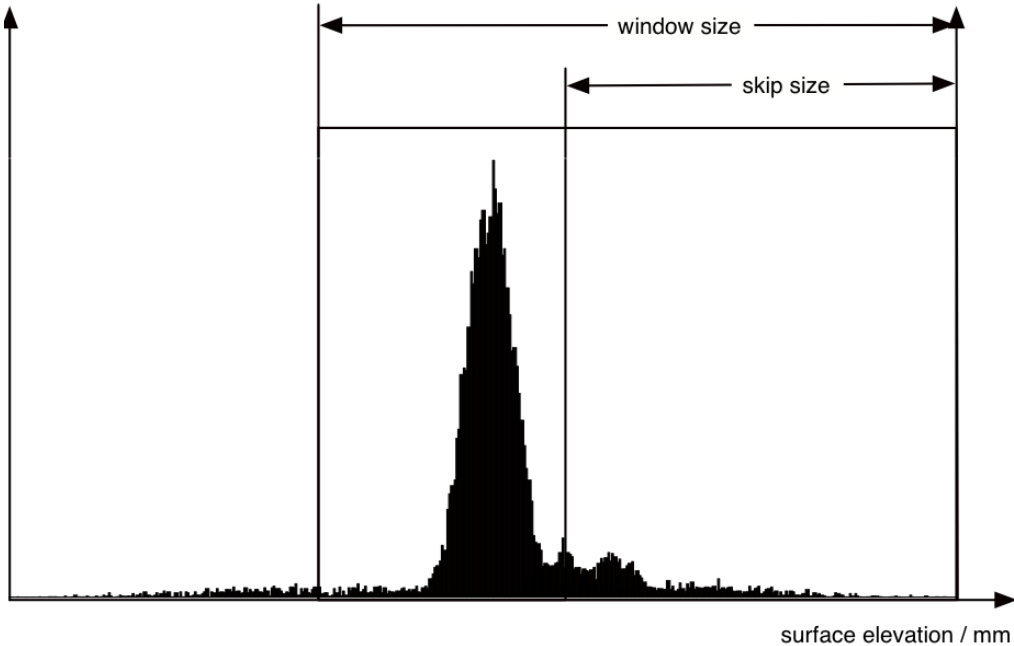

Profile Points and Bridge Algorithm Parameters

The bridge value can be delivered on Ethernet or the Selcom Serial output.

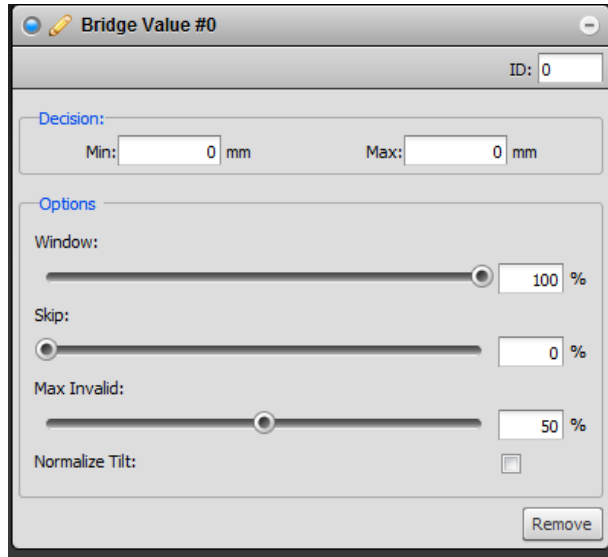

To enable bridge value output:

1. Add a bridge value measurement in the Measurement Page.
2. Configure the parameters in the Bridge Value panel. Note that all parameters are initialized to zero and users must configure them. The table below includes the suggested values equivalent to the default values in the RoLine 11xx.

Parameter	Explanations
Window size	<p>The percentage of the most elevated profile points passes into the bridging calculation. Window size <i>includes</i> the points covered by Window Skip.</p> <p>Suggested value: 50%</p>
Window skip	<p>The percentage of the most elevated profile points excluded by the bridging calculation.</p> <p>Suggested value: 15%</p>
Window invalid	<p>The minimum percentage of profile points required before the bridging calculation returns a valid result. The percentage is based on the number of <i>expected</i> profile points that is based on the active area settings.</p> <p>If the number of points is below this threshold, the calculation returns an “invalid” bridge value.</p> <p>Suggested value: 80%</p>
Normalize Profile	<p>Enable/disable the compensation of lateral tilt of the scanned surface.</p> <p>Suggested value: Enabled</p>

2.5.1 Selcom Serial

The Selcom Serial output consists of a clock and a data signal. The serial clock frequency can be 96 kHz or 512 kHz (the *Selcom Rate* setting), and is only running when data is being transmitted. Serial data is valid on the rising edge of the Selcom clock and is output MSB first, followed by control bits, for a total of 16 bits of information per frame. The time elapsed between the camera exposure and the delivery of the corresponding range data is fixed to a deterministic value.

Refer to section 5.1 on how to connect to the Gocator I/O connector for Selcom Serial operations.

Depending on the application, users can choose between four bit formats for the serial data output.

Method	Method Name
0	12 bit data SLS Mode
1	12 bit data with Search/Track bit
2	14 bit data
3	14 bit data with Search/Track bit

MSB is the most significant data bit, LSB is the least significant data bit, C indicates whether the data is invalid (invalid = high), and S indicates whether the data is acquired in search mode or track mode (search mode = high)

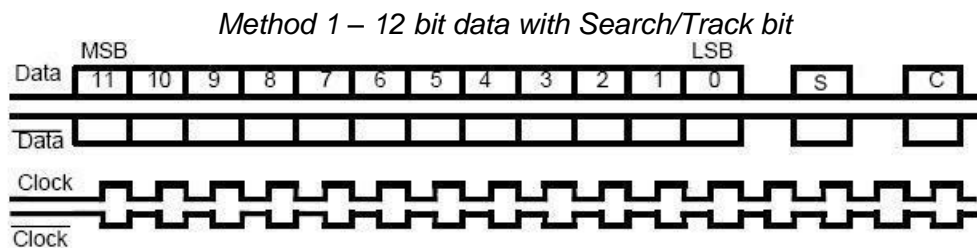
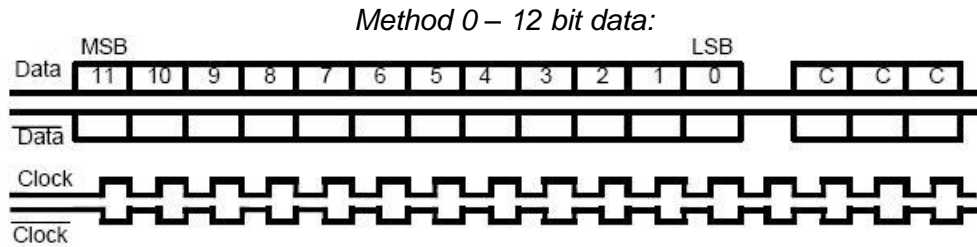

Method 2 – 14 bit data

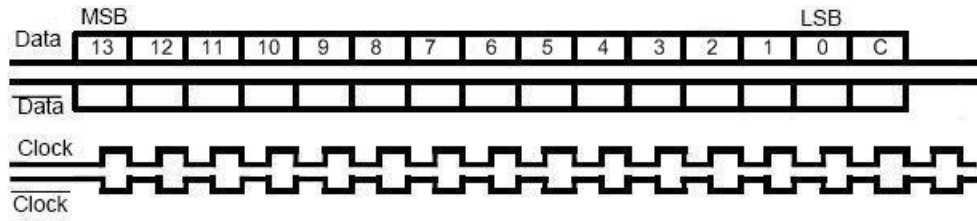

Method 3 – 14 bit data with Search/Track bit

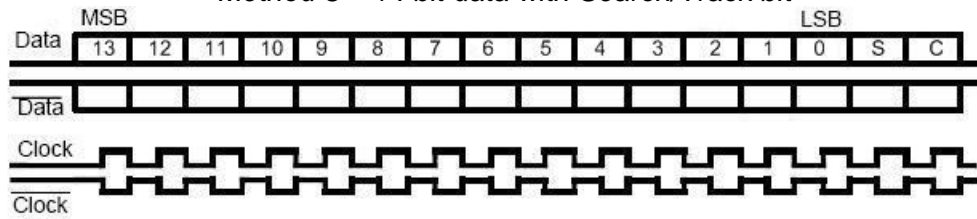

When delivered on the Selcom Serial, the bridged values are scaled according to the number of serial bits used to cover the measurement range. For example, the 12-bit output would break a 200mm measurement range into 4096 increments (0.0488mm/bit), and the 14-bit output would break a 200mm measurement range into 16384 increments (0.0122mm/bit). The bridged values are relative to the sensor's clearance distance.

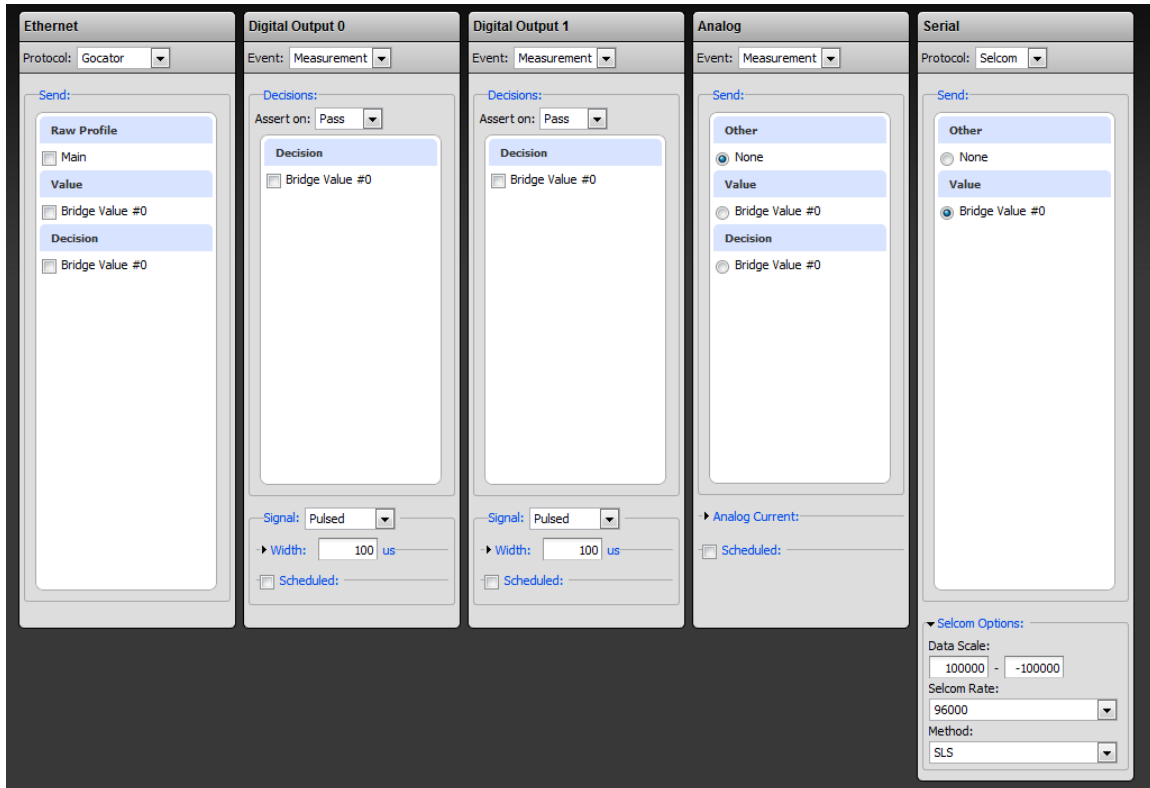

To output the bridge value on the Selcom Serial:

1. Select Selcom protocol in the Serial panel in the Output page.
2. Configure the parameters under the Selcom options in the Serial panel.

Parameter	Explanations
Protocol	Select Selcom to enable output in Selcom serial mode.
Data Scale	Control the range of data values that is mapped to the data output. By default, the full measurement range (i.e. -100mm to 100mm) are mapped to the output.
Selcom Rate	Selcom clock frequency (96kHz or 512 kHz).
Method	Selcom serial data output format (see explanations below)

2.6 Exposure Pulse

The Gocator can output a pulse on the digital output when the sensor exposes the data capture. This pulse can be used to latch data from external devices such as accelerometers. Using the frame count in the Ethernet Result message, the user can match the latched external data to each Gocator result.

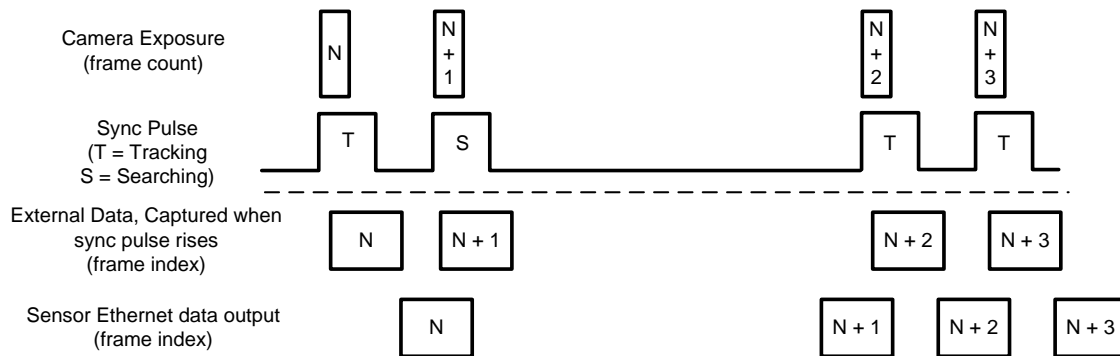

The exposure pulse replaces the RoLine's sync pulse. The difference is that when the sensor is in the searching state, one exposure pulse is generated for each exposed frame. In RoLine, four sync pulses are generated for each exposed frame.

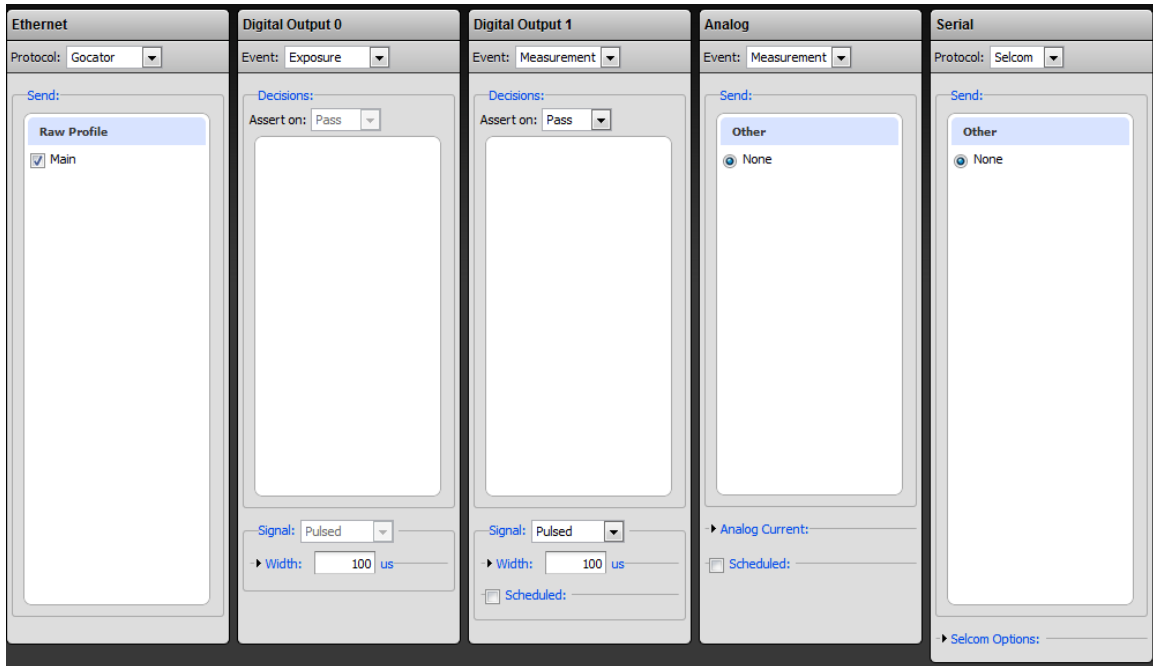

To enable the exposure pulse:

1. Select Exposure in the Event setting in the digital output panel.
2. Specify the pulse width

Gocator Protocol

3 Gocator Protocol

The Gocator 2342-3B-12 uses the Gocator Protocol to configure the sensor and deliver raw profiles and bridge values on the Ethernet.

The sections below explain the changes made for the Gocator 2342-3B-12. Refer to the Gocator User's manual for specifications of the Gocator Protocol.

3.1 Modes

"Roline" is the string for the RoLine operation mode.

3.2 Configuration Files

A BridgeValue element defines settings for a Bridge Value measurement.

Profile/Measurements/BridgeValue

BridgeValue Child Elements

Element	Type	Description
Name	String	Setting for measurement name.
Source	32u	Setting for profile source.
DecisionMin	64f	Setting for decision threshold minimum (mm).
DecisionMax	64f	Setting for decision threshold maximum (mm).
WindowSize	64f	Setting for percentage of spots to use, starting from the highest range value
WindowSkip	64f	Setting for [percentage of spots to ignore, starting from the highest range value.
MaxInvalid	32u	Setting for maximum number of invalid spots before the output is set to invalid.
NormalizeEnabled	32u	Setting to enable/disable tilt normalization: 0 – Disable 1 – Enable
SourceOptions	String	Constraint for eligible profile sources (comma-delimited list).

3.3 Data Result

Profiles are delivered using as *Profile Data (raw)* in a Profile Data Result. Bridge values are delivered as Measurement results with message type 0x32 and the unit is um.

Summary of Differences

4 Summary of Differences

The following table summarizes the difference between a Gocator and a RoLine 11xx.

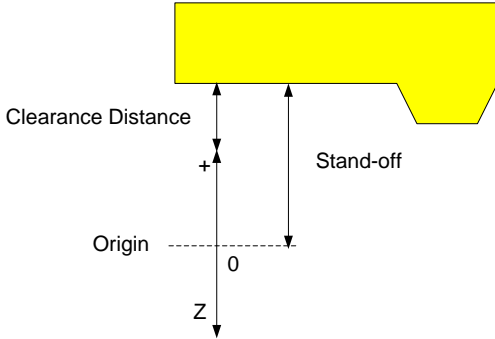
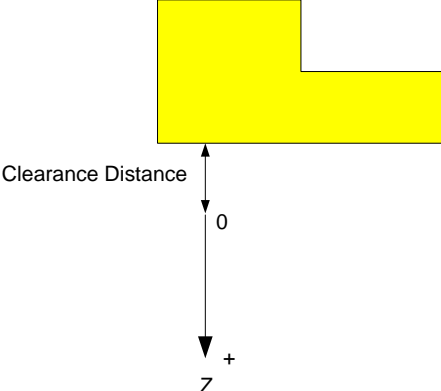
	Gocator 2342-3B-12	RoLine 11xx
Coordinate System	<p>After calibration, Z is positive when it is closer to the sensor than the standoff surface.</p> 	<p>Z increases as the data moves further away from the sensor.</p> 
Video mode	Returned image covers the sensor's active window measurement range, not only the tracking window.	Returned image covers only the tracking window.
Free mode	Format is always little endian. Refer to the User's Manual for definition of the Gocator result message.	Users can select little or big endian.
Sync Pulse	When the sensor is in the searching state, one exposure pulse is generated for each exposed frame.	When the sensor is in the searching state, four sync pulses is generated for each exposed frame.
Bridge Value Parameters	Window size, skip and invalid settings are specified in percentage of the total number of points.	Window size, skip and invalid settings are specified in number of points.
Selcom Serial data output	Gocator outputs one result for each frame captured in the searching state. See the picture at the end of this section.	RoLine 11xx outputs four results for each frame captured in the searching frame. See the picture at the end of this section.

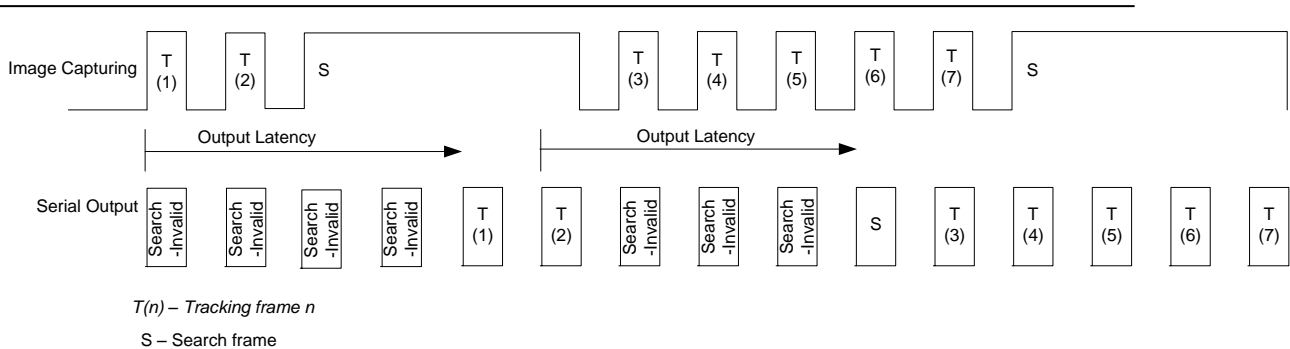

Figure 1. RoLine Selcom Serial output timing

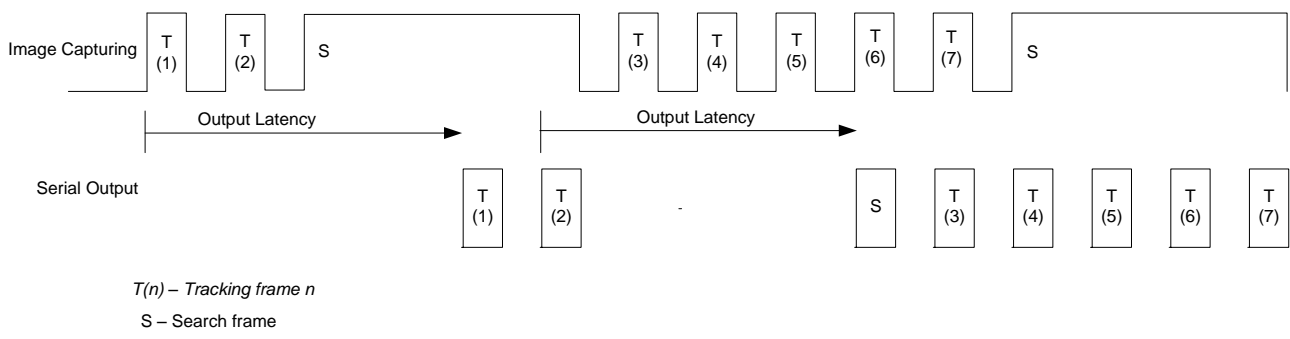

Figure 2. Gocator Selcom Serial output timing

Hardware

5 Hardware

The sensor optical specifications are identical to a standard Gocator 2340 sensor, except that a near infrared laser (NIR) laser replaces the red laser. Users must note that a NIR laser is not visible to human eyes when they turned on.

Gocator Laser Specification

Laser Classification: 3B/IIIb laser component
Peak Power: 450mW
Emitted Wavelength: 808nm

5.1 Selcom Serial Interface

The Selcom Serial output consists of a clock and data signal. The data signal is output on the Serial_Out+ / Serial_Out-, and the clock signal is output on reserved pins 15 and 16.

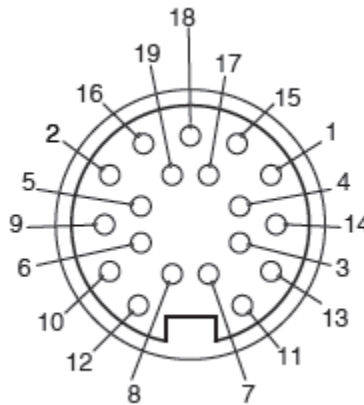
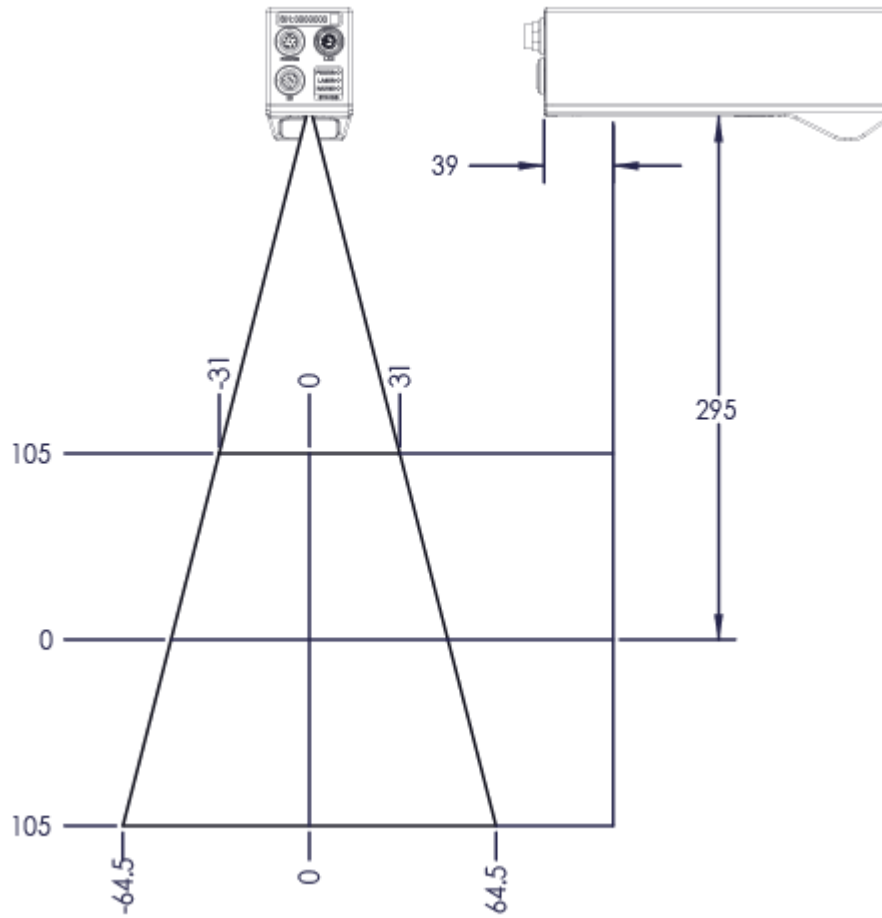

Figure 3 Gocator I/O Connector

Pin Number	Function	Conductor Color.
13	Serial_out+ (data+)	White
14	Serial_out- (data-)	Brown
15	Serial_out2+ (clock+)	Blue/Black
16	Serial_out2- (clock-)	White / Blue & Black

5.2 Field of View



5.3 Envelope

Gocator 2342 has the same envelope as the Gocator 2340. Refer to Gocator User Manual for the dimensions of the Gocator 2340.

5.4 Dimension

Gocator 2342 has the same dimensions as the Gocator 2340. Refer to Gocator User Manual for the dimensions of the Gocator 2340.