



USER'S MANUAL

Gocator 1100 & 1300 Series

Version 3.5.2.143 Revision: C

Copyright © 2012 by LMI Technologies, Inc. All rights reserved.

Proprietary

This document, submitted in confidence, contains proprietary information which shall not be reproduced or transferred to other documents or disclosed to others or used for manufacturing or any other purpose without prior written permission of LMI Technologies Inc.

No part of this publication may be copied, photocopied, reproduced, transmitted, transcribed, or reduced to any electronic medium or machine readable form without prior written consent of LMI Technologies, Inc.

Trademarks and Restrictions

Gocator™ is a registered trademark of LMI Technologies, Inc. Any other company or product names mentioned herein may be trademarks of their respective owners.

Information contained within this manual is subject to change.

This product is designated for use solely as a component and as such it does not comply with the standards relating to laser products specified in U.S. FDA CFR Title 21 Part 1040.

Contact Information

For more information, please contact LMI Technologies.

LMI Technologies, Inc.
1673 Cliveden Ave.
Delta, BC V3M 6V5
Canada

Telephone: +1 604 636 1011
Facsimile: +1 604 516 8368

www.lmi3d.com

Introduction

The Gocator 1100 and 1300 series of laser displacement sensors are designed for 3D measurement and control applications. Gocator sensors are configured using a web browser and can be connected to a variety of input and output devices. This guide describes the installation and use of Gocator sensors.

Notational Conventions

This guide uses the following notational conventions:

 Warning Follow these safety guidelines to avoid potential injury or property damage.

 Note Consider this information in order to make best use of the product.

Table of Contents

Introduction	3
Table of Contents	4

Safety and Maintenance **8**

Laser Safety	8
Laser Classes	9
Precautions and Responsibilities	10
Class 3B Responsibilities	10
Systems Sold or Used in the USA	11
Electrical Safety	12
Environment and Lighting	13
Sensor Maintenance	13

Getting Started **15**

System Overview	15
Standalone System	15
Dual Sensor System	16
Multi-Sensor System	17
Hardware	18
Side Mount Package	18
Top Mount Package	19
Master 100	20
Master 400/800	21
Master 1200/2400	22
Gocator Cordsets	23
Calibration Targets	24
Installation	25
Grounding - Gocator	25
Grounding - Master 400/800/1200/2400	25
Mounting (Side Mount Package)	26
Mounting (Top Mount Package)	28
Orientations	30
Software	32
User Interface Overview	32
Connecting to a New Sensor	33
Running for the First Time	35
Running a Standalone Sensor System	35
Running a Dual Sensor System	37
Next Steps	41

Setup and Calibration **42**

Setup Page	42
Operation Modes	44

Data Viewer	45
Video Mode	45
Range Mode	46
Region Definition	47
Data Viewer Controls	47
Range Output	48
Coordinate Systems	48
Intensity Output	50
Trigger	51
Examples	53
Settings	55
Active Area	56
Exposure	58
Single Exposure	59
Dynamic Exposure	60
Transformations	61
Dual Sensor System Layout	62
Calibration	63
Calibration States	63
Alignment vs. Travel Calibration	63
Alignment Calibration	64
Travel Calibration	65
Clearing Calibration	66

Measurement **67**

Measurement Page	67
Adding and Removing Measurements	68
Changing the Measurement Name	69
Range Sources	71
Decisions	72
Output Filters	73
Script Measurement	74
Built-in Functions	74

Range Measurement Tools **78**

Measurement Types	79
Difference	79
Position Z	80
Script	81

Output **82**

Output Page	82
Ethernet Control and Output	83

Digital Outputs	87	Command Channels	125
Analog Output	90	Result Channels	125
Serial Output	92	Modes	126
<hr/>			
Toolbar	94	Buddy Communication Channels	126
Saving and Loading Settings	95	States	126
Managing Multiple Settings	97	Versions and Upgrades	126
Recording and Playback	98	Data Types	127
Downloading, Exporting and Uploading		Range Sources	127
Recorded Data	99	Status Codes	127
<hr/>			
Dashboard	100	Command and Reply Formats	128
Dashboard Page	100	Result Format	129
State and Health Information	101	Discovery Commands	130
Metric Panel	103	Get Address	130
<hr/>			
Connection and Maintenance	104	Set Address	131
Connection Page	104	Upgrade Commands	132
Network Settings	105	Get Protocol Version	132
Auto Starting Sensors	106	Start Upgrade	132
Overheat Protection	106	Get Upgrade Status	132
Buddy Assignment	108	Get Upgrade Log	133
Security	109	Control Commands	134
File Management	110	Get Protocol Version	134
Maintenance	111	Get System Info	134
Firmware Upgrade	112	Log In/Out	135
<hr/>			
Recovery	113	Change Password	136
Sensor Recovery Tool	113	Change Buddy	136
<hr/>			
Gocator Configuration File	114	Get File List	136
Setup	114	Copy File	137
Range	117	Read File	137
Output	119	Write File	137
Calibration File	122	Delete File	138
SysCal	123	Get Default File	138
<hr/>			
Gocator Protocol	124	Set Default File	139
Concepts	125	Get Loaded File	139
Discovery	125	Get Mode	139
<hr/>			
		Set Mode	140
		Get Time	140
		Get Encoder	140
		Start	141
		Scheduled Start	141
		Stop	141
		Trigger	142
		Scheduled Digital Output	142
		Scheduled Analog Output	143
		Ping	143
		Reset	143
		Backup	144
		Restore	144
		Restore Factory	144
		Set Connection Type	145
		Get Connection Type	145
		Clear Calibration	146
		Data Results	147
		Video	147
		Range	147

Range Intensity	148
Alignment Calibration	148
Travel Calibration	148
Exposure Calibration	149
Measurement	150
Health Results	151

Modbus TCP Protocol 163

Concepts	163
Messages	164
Registers	166
Control Registers	166
Output Registers	167
Measurement Registers	168

EtherNet/IP 169

Concept	169
Basic Object	170
Identity Object (Class 0x01)	170
TCP/IP Object (Class 0xF5)	170
Ethernet Link Object (Class 0xF6)	171
Assembly Object (Class 0x04)	172
Command Object	172
Sensor State Assembly Object	173
Sample State Assembly	174

ASCII Protocol 175

Ethernet Communication	175
Asynchronous and Polling Operation	175
Serial Communication	175
Command and Reply Format	176
Special Characters	176
Standard Result Format	176
Custom Result Format	177
Control Commands	178
Start	178
Stop	178
Trigger	178
Load Configuration	179
Stamp	179
Alignment Calibration	180
Travel Calibration	180
Clear Calibration	180
Data Commands	181
Get Result	181
Get Value	181
Get Decision	182

Health Commands	183
Get Health	183

Selcom Serial Protocol 184

Connection Settings	184
Message Format	184

Software Development Kit 186

Troubleshooting 187

Mechanical/Environmental	187
Connection	187
Laser Ranging	187
Performance	188

Specification 189

Gocator 1100 Series	189
Gocator 1300 Series	190
Gocator 1120/1320 (Side Mount Package)	192
Gocator 1120/1320 (Top Mount Package)	194
Gocator 1125/1325 (Side Mount Package)	196
Gocator 1125/1325 (Top Mount Package)	198
Gocator 1150/1350 (Side Mount Package)	200
Gocator 1150/1350 (Top Mount Package)	203
Gocator 1160/1360 (Side Mount Package)	206
Gocator 1160/1360 (Top Mount Package)	209
Gocator 1165/1365 (Side Mount Package)	212
Gocator 1165/1365 (Top Mount Package)	215
Gocator 1170/1370 (Side Mount Package)	218
Gocator 1170/1370 (Top Mount Package)	221
Gocator 1190/1390 (Side Mount Package)	224
Gocator 1190/1390 (Top Mount Package)	227
Gocator 1100/1300 Power/LAN Connector	230
Grounding Shield	230
Power	230
Laser Safety Input	231
Gocator 1100 and 1300 I/O Connector	232
Grounding Shield	232
Digital Outputs	233
Digital Inputs	234
Encoder Input	234
Serial Output	235
Selcom Serial Output	236
Analog Output	237
Master 100	238

Master 100 Dimensions	239
Master 400/800	240
Master 400/800 Electrical Specifications	241
Master 400/800 Dimensions	242
Master 1200/2400	243
Master 1200/2400 Electrical Specifications	244
Master 1200/2400 Dimensions	244

Parts and Accessories **245**

Warranty and Return Policy **249**

Warranty Policy	249
Return Policy	249

Software Licenses **250**

Support **254**

Safety and Maintenance

Laser Safety

Gocator sensors contain semiconductor lasers that emit visible light and are designated as Class 2M, Class 3R, or Class 3B, depending on the chosen laser option.

Gocator sensors are referred to as *components*, indicating that they are sold only to qualified customers for incorporation into their own equipment. These sensors do not incorporate safety items that the customer may be required to provide in their own equipment (e.g. remote interlocks, key control. Refer to references for detail information). As such, these sensors do not fully comply with the standards relating to laser products specified in IEC 60825-1 and FDA CFR Title 21 Part 1040.

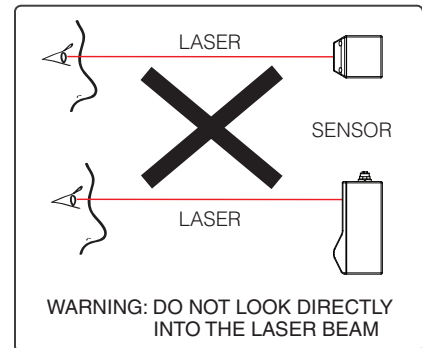

Use of controls or adjustments or performance of procedures other than those specified herein may result in hazardous radiation exposure.

References

1. *International standard IEC 60825-1 (2001-08) consolidated edition*, Safety of laser products – Part 1: Equipment classification, requirements and user's guide.
2. *Technical report 60825-10*, Safety of laser products – Part 10. Application guidelines and explanatory notes to IEC 60825-1.
3. *Laser Notice No. 50*, FDA and CDRH <http://www.fda.gov/cdrh/rad-health.html>

Laser Classes

Class 2M laser components

Class 2M laser components would not cause permanent damage to the eye under reasonably foreseeable conditions of operation, provided that any exposure can be terminated by the blink reflex (assumed to take 0.25 seconds). Because classification assumes the blink reflex, the wavelength of light must be in the visible range (400 nm to 700 nm). The Maximum Permissible Exposure (MPE) for visible radiation for 0.25 seconds is 25 watts per square meter, which is equivalent to 1 mW entering an aperture of 7 mm diameter (the assumed size of the pupil).

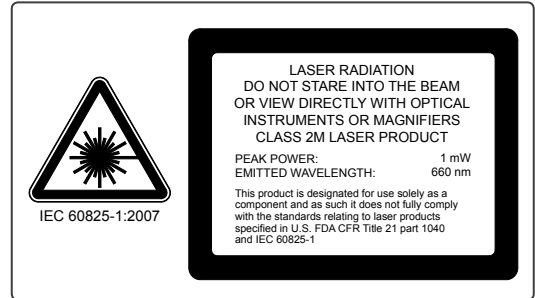

Class 3R laser components

Class 3R laser products emit radiation where direct intrabeam viewing is potentially hazardous, but the risk is lower with 3R lasers than for 3B lasers. Fewer manufacturing requirements and control measures for 3R laser users apply than for 3B lasers.

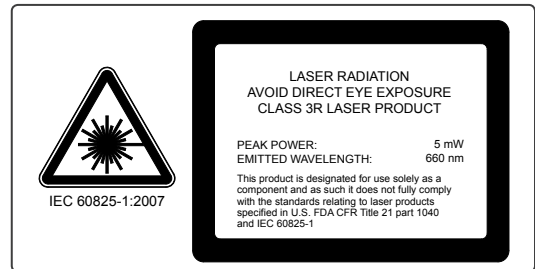

Class 3B laser components

Class 3B components are unsafe for eye exposure. Usually only ocular protection will be required. Diffuse reflections are safe if viewed for less than 10 seconds.

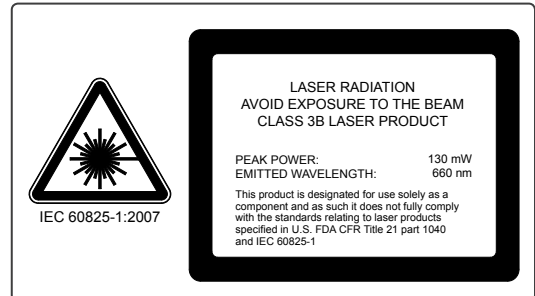

 Labels reprinted here are examples only. For accurate specifications, refer to the label on your sensor.

Precautions and Responsibilities

Precautions specified in IEC 60825-1 and FDA CFR Title 21 Part 1040 are as follows:

Requirement	Class 2M	Class 3R	Class 3B
Remote interlock	Not required	Not required	Required*
Key control	Not required	Not required	Required – cannot remove key when in use*
Power-on delays	Not required	Not required	Required*
Beam attenuator	Not required	Not required	Required*
Emission indicator	Not required	Not required	Required*
Warning signs	Not required	Not required	Required*
Beam path	Not required	Terminate beam at useful length	Terminate beam at useful length
Specular reflection	Not required	Prevent unintentional reflections	Prevent unintentional reflections
Eye protection	Not required	Not required	Required under special conditions
Laser safety officer	Not required	Not required	Required
Training	Not required	Required for operator and maintenance personnel	Required for operator and maintenance personnel

**LMI Class 3B laser components do not incorporate these laser safety items. These items must be added and completed by the customer in their system design.*

Class 3B Responsibilities

LMI Technologies has filed reports with the FDA to assist customers in achieving certification of laser products. These reports can be referenced by an accession number, provided upon request. Detailed descriptions of the safety items that must be added to the system design are listed below.

Remote Interlock

A remote interlock connection must be present in Class 3B laser systems. This permits remote switches to be attached in serial with the keylock switch on the controls. The deactivation of any remote switches must prevent power from being supplied to any lasers.

Key Control

A key operated master control to the lasers is required that prevents any power from being supplied to the lasers while in the OFF position. The key can be removed in the OFF position but the switch must not allow the key to be removed from the lock while in the ON position.

Power-On Delays

A delay circuit is required that illuminates warning indicators for a short period of time prior to supplying power to the lasers.

Beam Attenuators

A permanently attached method of preventing human access to laser radiation other than switches, power connectors or key control must be employed. On some LMI laser sensors, the beam attenuator is supplied with the sensor as an integrated mechanical shutter.

Emission Indicator

It is required that the controls that operate the sensors incorporate a visible or audible indicator when power is applied and the lasers are operating. If the distance between the sensor and controls is more than 2 meters, or mounting of sensors intervenes with observation of these indicators, then a second

power-on indicator should be mounted at some readily-observable position. When mounting the warning indicators, it is important not to mount them in a location that would require human exposure to the laser emissions. User must ensure that the emission indicator, if supplied by OEM, is visible when viewed through protective eyewear.

Warning Signs

Laser warning signs must be located in the vicinity of the sensor such that they will be readily observed. Examples of laser warning signs are as follows:

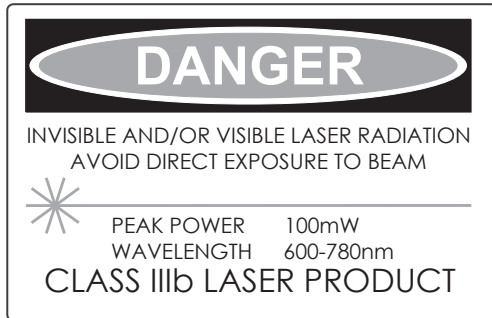

FDA warning sign example



IEC warning sign example

Systems Sold or Used in the USA

Systems that incorporate laser components or laser products manufactured by LMI Technologies require certification by the FDA.

Customers are responsible for achieving and maintaining this certification.

Customers are advised to obtain the information booklet *Regulations for the Administration and Enforcement of the Radiation Control for Health and Safety Act of 1968: HHS Publication FDA 88-8035*.

This publication, containing the full details of laser safety requirements, can be obtained directly from the FDA, or downloaded from their web site at <http://www.fda.gov/cdrh>.

Electrical Safety

Sensors should be connected to earth ground

All sensors should be connected to earth ground through their housing. All sensors should be mounted on an earth grounded frame using electrically conductive hardware to ensure the housing of the sensor is connected to earth ground. Use a multi-meter to check the continuity between the sensor connector and earth ground to ensure a proper connection.

Minimize voltage potential between system ground and sensor ground

Care should be taken to minimize the voltage potential between system ground (ground reference for I/O signals) and sensor ground. This voltage potential can be determined by measuring the voltage between *Analog_out-* and *system ground*. The maximum permissible voltage potential is 12 V but should be kept below 10 V to avoid damage to the serial and encoder connections. Refer to Gocator 1100 and 1300 I/O Connector (page 232) for a description of connector pins.

Use a suitable power supply

The +24 to +48 VDC power supply used with Gocator sensors should be an isolated supply with inrush current protection or be able to handle a high capacitive load.

Use care when handling powered devices

Wires connecting to the sensor should not be handled while the sensor is powered. Doing so may cause electrical shock to the user or damage to the equipment.



Failure to adhere to the guidelines described in this section may result in electrical shock or equipment damage.

Environment and Lighting

Avoid strong ambient light sources

The imager used in this product is highly sensitive to ambient light hence stray light may have adverse effects on measurement. Do not operate this device near windows or lighting fixtures that could influence measurement. If the unit must be installed in an environment with high ambient light levels, a lighting shield or similar device may need to be installed to prevent light from affecting measurement.

Avoid installing sensors in hazardous environments

To ensure reliable operation and to prevent damage to Gocator sensors, avoid installing the sensor in locations;

- that are humid, dusty, or poorly ventilated
- with a high temperature, such as places exposed to direct sunlight
- where there are flammable or corrosive gases
- where the unit may be directly subjected to harsh vibration or impact
- where water, oil, or chemicals may splash onto the unit
- where static electricity is easily generated

Ensure that ambient conditions are within specifications

Gocator sensors are suitable for operation between 0 – 50 °C and 25 – 85% relative humidity (non-condensing). Measurement error due to temperature is limited to 0.015% of full scale per degree C.

The Master 100/400/800/1200/2400 is similarly rated for operation between 0 – 50 °C.

The storage temperature is -30 – 70 °C.



It is critical that the sensor is heat sunk through the frame it is mounted to. When a sensor is properly heat sunk, the difference between ambient temperature and the temperature reported in the sensor's health channel is less than 15 °C.

Gocator sensors are high accuracy devices. It is critical that the temperature of all of its components are in equilibrium. When the sensor is powered up, a warm-up time of at least one hour is required in order to reach a consistent spread of temperature within the sensor.

Sensor Maintenance

Keep sensor windows clean

Gocator sensors are high-precision optical instruments. To ensure the highest accuracy is achieved in all measurements, the windows on the front of the sensor should be kept clean and clear of debris.

Use care when cleaning sensor windows

Use dry, clean air to remove dust or other dirt particles. If dirt remains, clean the windows carefully with a soft, lint-free cloth and non-streaking glass cleaner or isopropyl alcohol. Ensure that no residue is left on the windows after cleaning.

Turn off lasers when not in use

LMI Technologies uses semiconductor lasers in 3D measurement sensors. To maximize the lifespan of the sensor, turn off the laser when not in use.

Avoid excessive modifications to files stored on the sensor

Settings for Gocator sensors are stored in flash memory inside the sensor. Flash memory has an expected lifetime of 100,000 writes. To maximize lifetime, avoid frequent or unnecessary file save operations.

Getting Started

System Overview

Gocator sensors can be installed and used in a variety of scenarios. Sensors can be connected as standalone devices, dual sensor (Main and Buddy) system, or multi-sensor system.

Standalone System

Standalone systems are typically used when only a single Gocator sensor is required. The sensor can be connected to a computer's Ethernet port for setup and can also be connected to devices such as encoders, photocells, or PLCs.

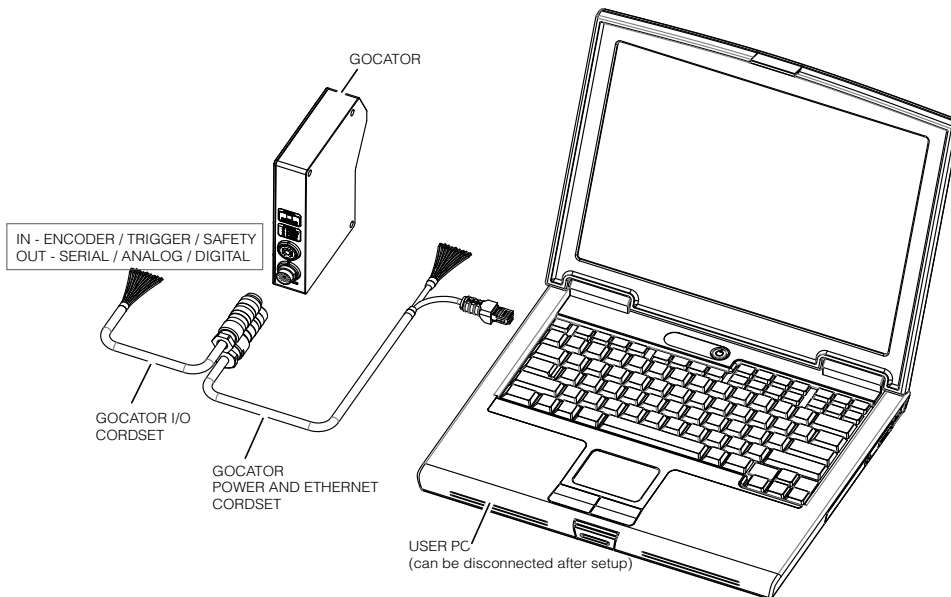

Dual Sensor System

In a dual sensor system, two Gocator sensors work together to perform ranging and output the combined results. The controlling sensor is referred to as the Main sensor, and the helper is referred to as the Buddy sensor. Gocator's software recognizes three installation orientations – None, Opposite and Wide.

A Master 400/800/1200/2400 must be used to connect two sensors in a Dual Sensor (Buddy) system. Gocator Master cordsets are used to connect sensors to the Master.

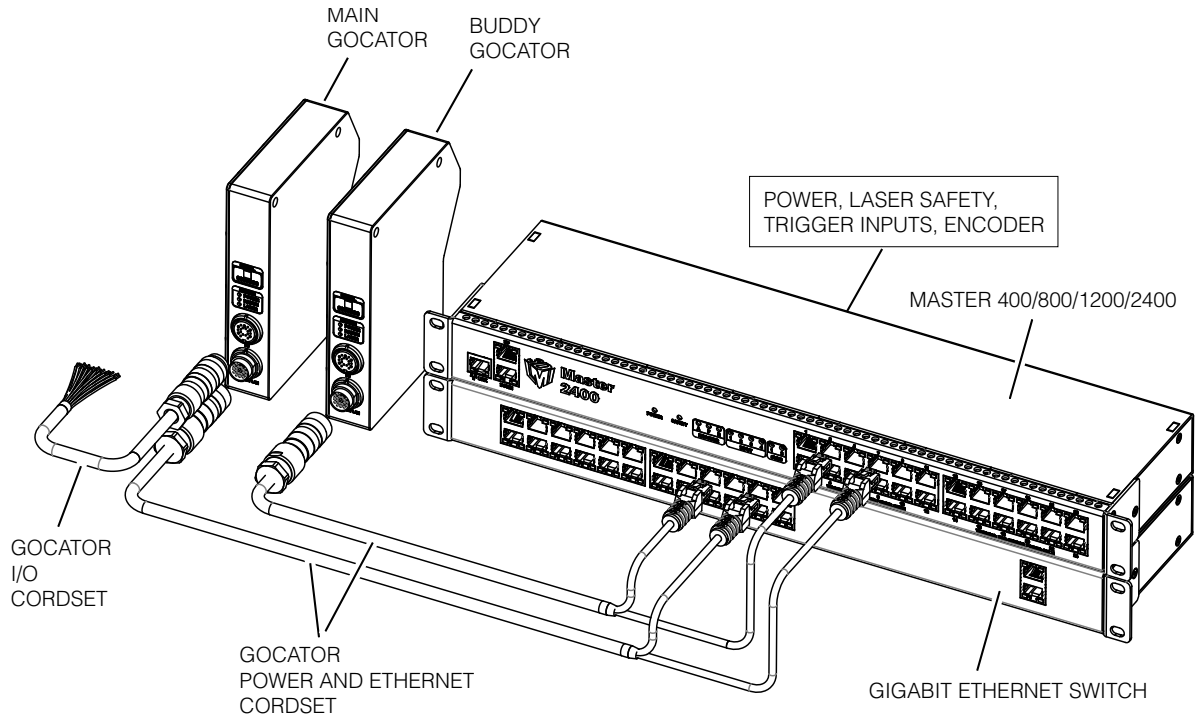

Multi-Sensor System

Master 400/800/1200/2400 networking hardware can be used to connect two or more sensors into a Multi-sensor system. Gocator Master cordsets are used to connect the sensors to a Master. The Master provides a single point of connection for power, safety, encoder and digital inputs. A Master 400/800/1200/2400 can be used to ensure that the scan timing is precisely synchronized across sensors. Sensors and client computers communicate via an Ethernet switch (minimum 100 Mbit/s).

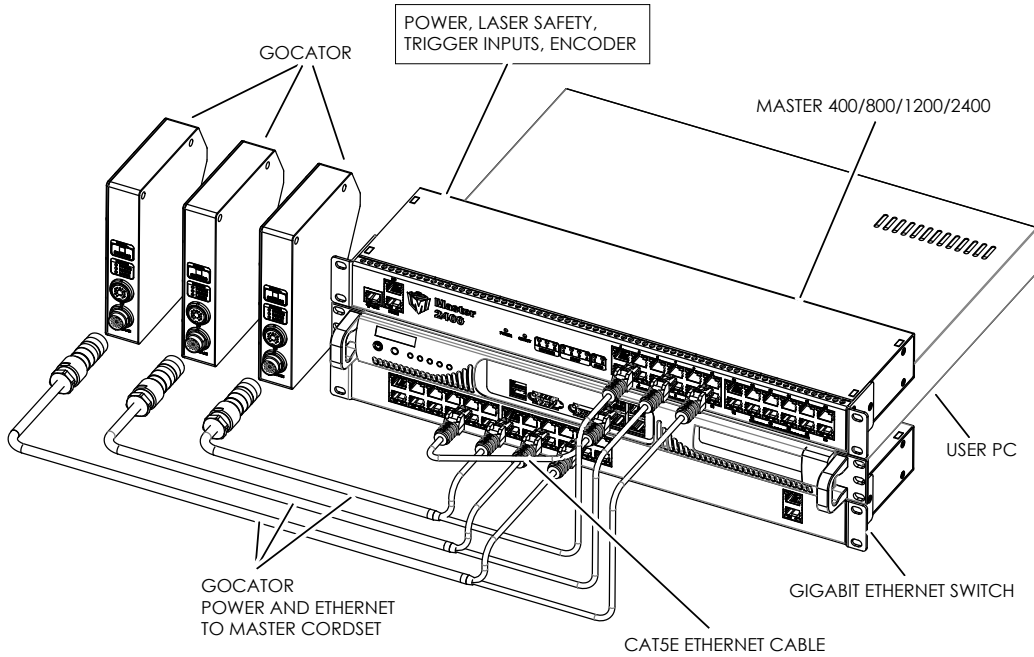

Hardware

The Gocator 1100 and 1300 sensors are available in either the Top Mount Package or the Side Mount Package. Side Mount Package is designed for side mounting and the Top Mount Package is designed for top mounting.

Side Mount Package

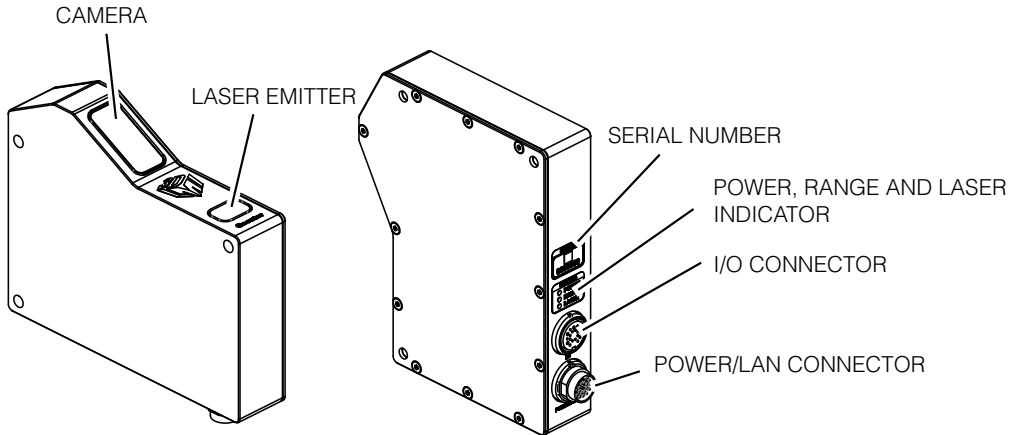

Item	Description
Camera	Observes laser light reflected from target surfaces.
Laser Emitter	Emits structured light for laser ranging.
I/O Connector	Accepts input and output signals.
Power / LAN Connector	Accepts power and laser safety signals and connects to 1000 Mbit/s Ethernet network.
Power Indicator	Illuminates when power is applied (blue).
Range Indicator	Illuminates when camera detects laser light and is within the target range (green).
Laser Indicator	Illuminates when laser safety input is active (amber).
Serial Number	Unique sensor serial number.

Top Mount Package

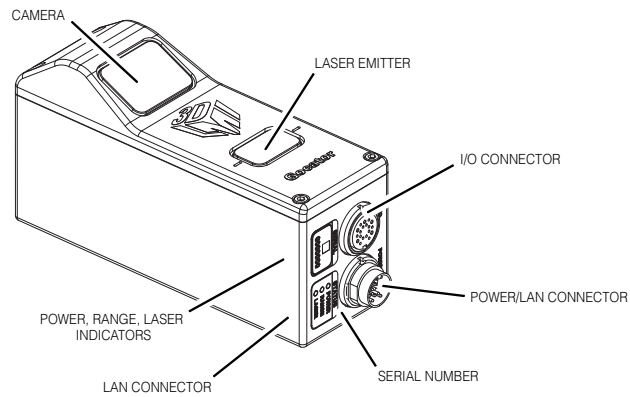

Item	Description
Camera	Observes laser light reflected from target surfaces.
Laser Emitter	Emits structured light for laser ranging.
I/O Connector	Accepts input and output signals.
Power / LAN Connector	Accepts power and laser safety signals and connects to 1000 Mbit/s Ethernet network.
Power Indicator	Illuminates when power is applied (blue).
Range Indicator	Illuminates when camera detects laser light and is within the target range (green).
Laser Indicator	Illuminates when laser safety input is active (amber).
Serial Number	Unique sensor serial number.

Master 100

The Master 100 is used by the Gocator 1100 and 1300 series for standalone system setup. The Master 100 is designed for development use only.

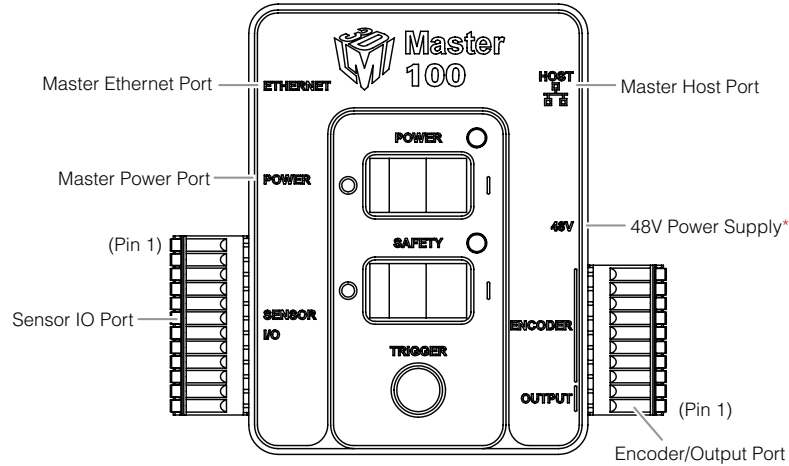

Item	Description
Gocator Power Port	Connects to the Gocator Power/LAN connector. Provides power and laser safety to the Gocator.
Gocator Sensor I/O Port	Connects to the Gocator I/O connector.
Laser Safety Switch	Toggles laser safety signal provided to the sensors [O= laser off, I= laser on].
Power Switch	Toggles sensor power.
Trigger	Signals a digital input trigger to the Gocator.
Encoder	Accepts encoder A, B and Z signals.
Digital Output	Provides digital output.
Power	Accepts power (+48 V).

Refer to Master 100 (page 238) for pinout details.

Master 400/800

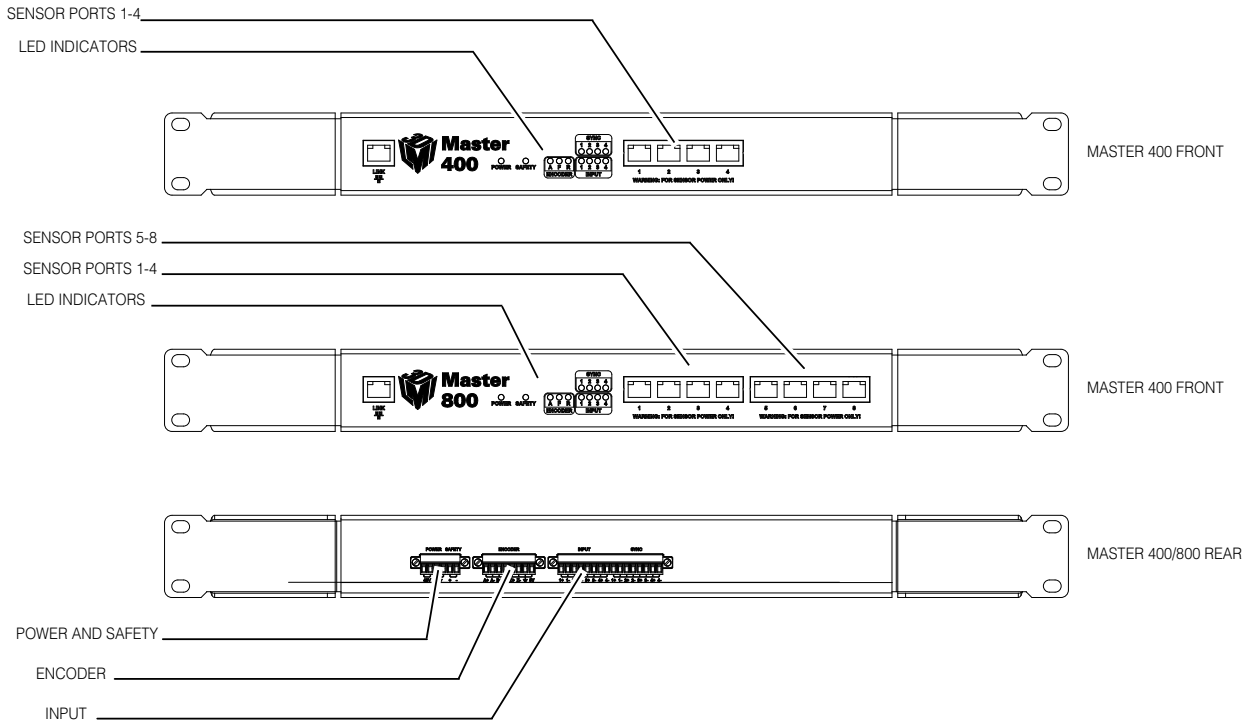

Item	Description
Sensor Ports	Master connection for Gocator sensors (no specific order required).
Ground Connection	Earth ground connection point.
Laser Safety	Laser safety connection.
Encoder	Accepts encoder signal.
Input	Accepts digital input.

Refer to Master 400/800 (page 240) for pinout details.

Master 1200/2400

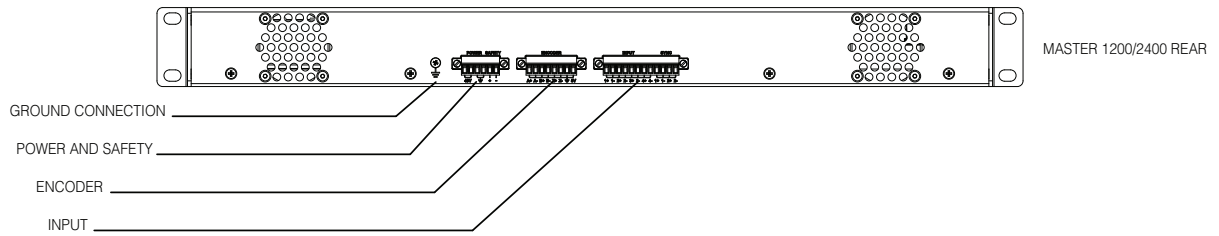
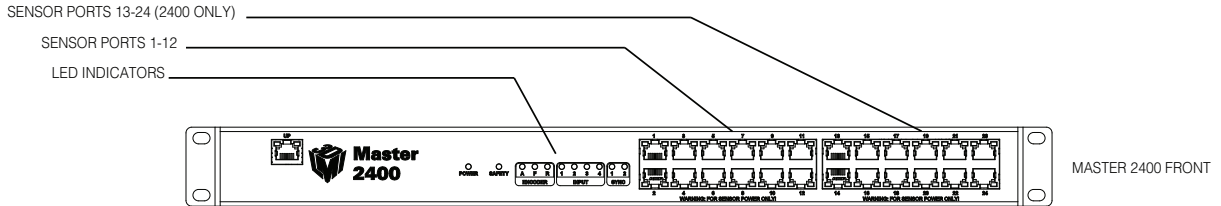
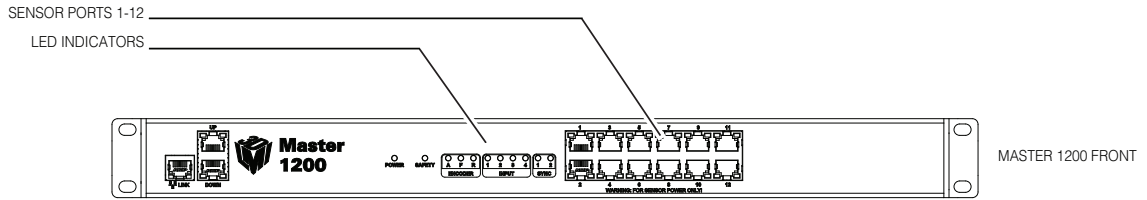

Item	Description
Sensor Ports	Master connection for Gocator sensors (no specific order required).
Ground Connection	Earth ground connection point.
Laser Safety	Laser safety connection.
Encoder	Accepts encoder signal.
Input	Accepts digital input.

Refer to Master 1200/2400 (page 243) for pinout details.

Gocator Cordsets

Gocator sensors use two types of cordsets. The Power & Ethernet cordset provides power, laser safety locklock to the sensor. It is also used for sensor communication via 1000 Mbit/s Ethernet with a standard RJ45 connector. The Gocator I/O cordset provides digital I/O connections, an encoder interface, RS-485 serial connection, and an analog output. The Master version of the Power & Ethernet cordset provides direct connection between the sensor and a Master 400/800/1200/2400.

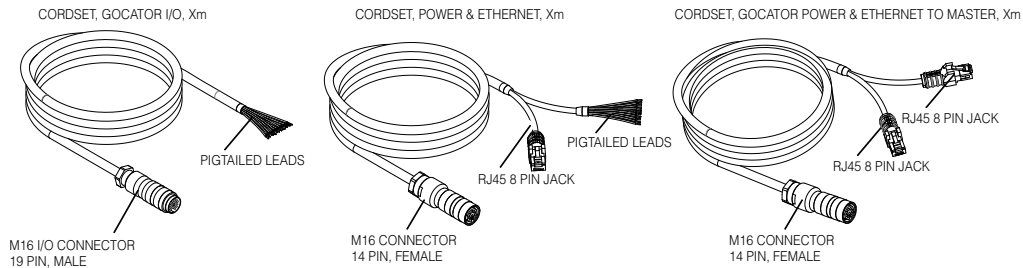

The maximum cordset length is 60m. Refer to Gocator 1100 and 1300 I/O Connector (page 232) and Gocator 1100/1300 Power/LAN Connector (page 230) for pinout details. Refer to Parts and Accessories (page 245) for cordset lengths and part numbers. Contact LMI for information on creating cordsets with custom length or connector orientation.

Calibration Targets

Calibration targets are used for *travel calibration*. It provides a step change of known dimensions (in the Y-axis) which allows sensor to calculate the Z-offset and encoder resolution of the system.

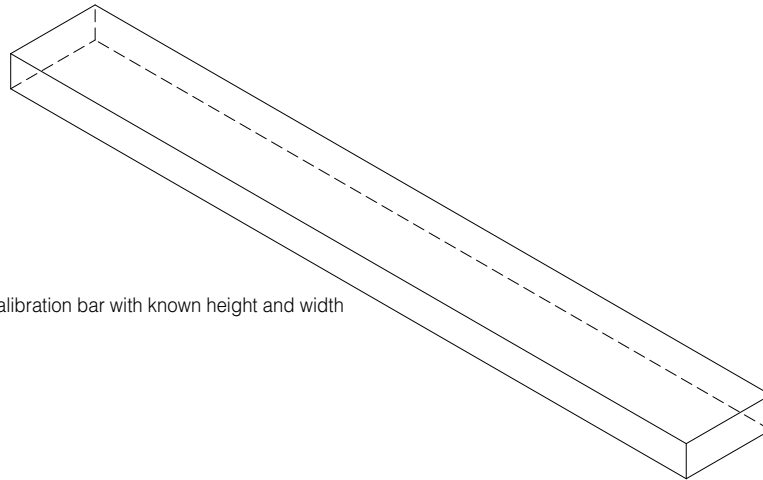

Calibration bar with known height and width

Refer to Calibration (page 63) for more information on calibration procedures.

Installation

Grounding - Gocator

Gocators should be grounded to the earth/chassis through their housings and through the grounding shield of the Power I/O cordset. Gocator sensors have been designed to provide adequate grounding through the use of M6 x 1.0 pitch mounting screws. Always check grounding with a multi-meter to ensure electrical continuity between the mounting frame and the Gocator's connectors.



It is imperative that the frame or electrical cabinet that the Gocator is mounted to is connected to earth ground.

Grounding - Master 400/800/1200/2400

The mounting brackets of all Masters have been designed to provide adequate grounding through the use of star washers. Always check grounding with a multi-meter by ensuring electrical continuity between the mounting frame and RJ45 connectors on the front.



It is imperative that the frame or electrical cabinet that the Master is mounted to is connected to earth ground.

Mounting (Side Mount Package)

Sensors should be mounted using four M6 x 1.0 pitch screws of suitable length. The recommended thread engagement into the housing is 8 - 10 mm. Proper care should be taken in order to ensure that the internal threads are not damaged from cross-threading or improper insertion of screws.

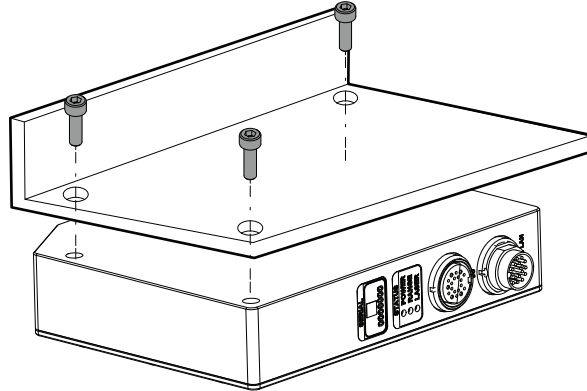

Sensors should not be installed near objects that might occlude a camera's view of the laser.

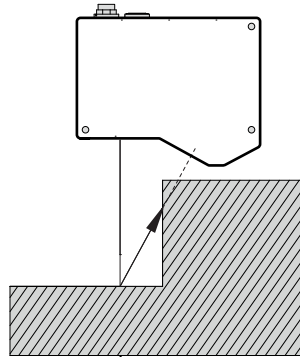

Sensors should not be installed near surfaces that might create unanticipated laser reflections.

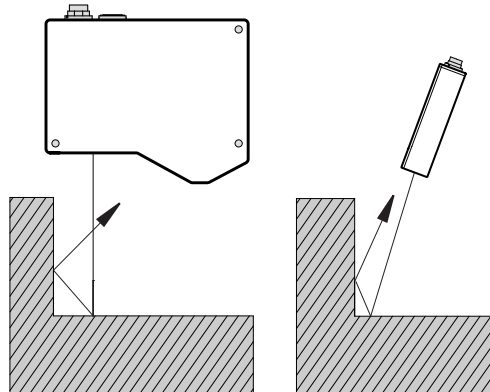



It is critical that the sensor is heat sunk through the frame it is mounted to. When a sensor is properly heat sunk, the difference between ambient temperature and the temperature reported in the sensor's health channel is less than 15 °C.



Gocator sensors are high accuracy devices. It is critical that the temperature of all of its components are in equilibrium. When the sensor is powered up, a warm-up time of at least one hour minutes is required in order to reach a consistent spread of temperature within the sensor.

Mounting (Top Mount Package)

Sensors should be mounted using four M5 x 0.8 pitch screws of suitable length. The recommended thread engagement into the housing is 8 - 10 mm. Proper care should be taken in order to ensure that the internal threads are not damaged from cross-threading or improper insertion of screws.

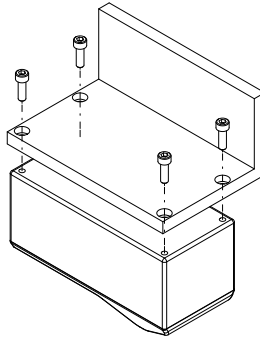

Sensors should not be installed near objects that might occlude a camera's view of the laser.

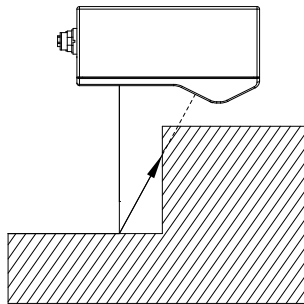

Sensors should not be installed near surfaces that might create unanticipated laser reflections.



It is critical that the sensor is heat sunk through the frame it is mounted to. When a sensor is properly heat sunk, the difference between ambient temperature and the temperature reported in the sensor's health channel is less than 15 °C.



Gocator sensors are high accuracy devices. It is critical that the temperature of all of its components are in equilibrium. When the sensor is powered up, a warm-up time of at least one hour is required in order to reach a consistent spread of temperature within the sensor.

Orientations

The examples below illustrate the possible mounting orientations for standalone and dual sensor system. For more information on orientations, refer to Dual Sensor System Layout (page 62).

Single Sensor Orientations:

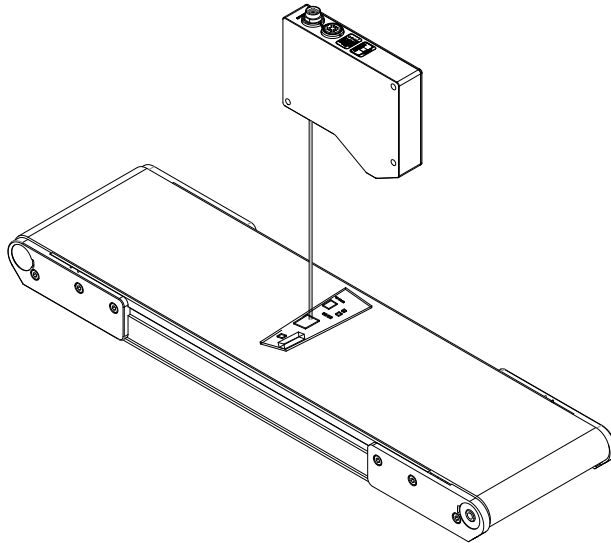

Single sensor above conveyor

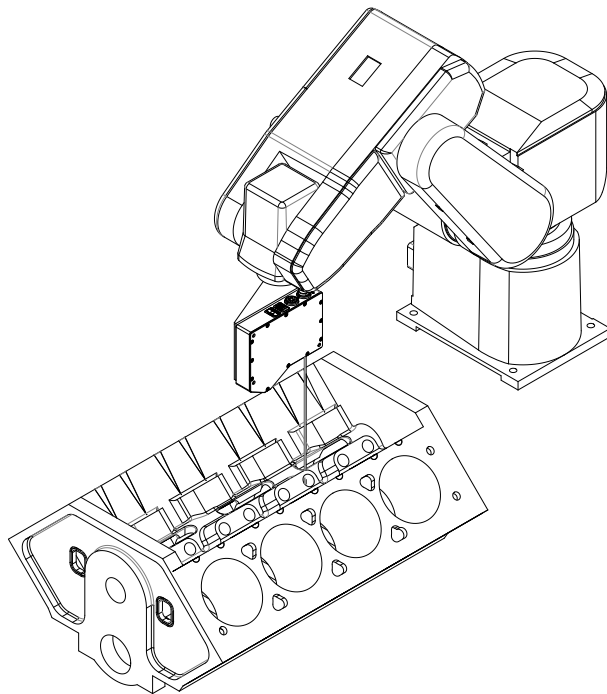

Single sensor on robot arm

Dual Sensor System Orientations:

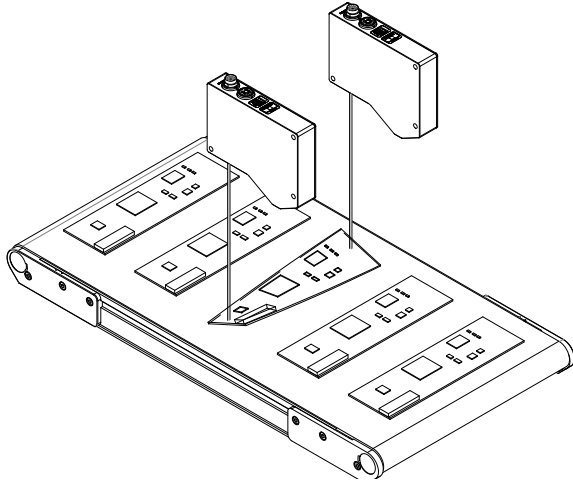

Side-by-side for wide-area measurement (Wide)

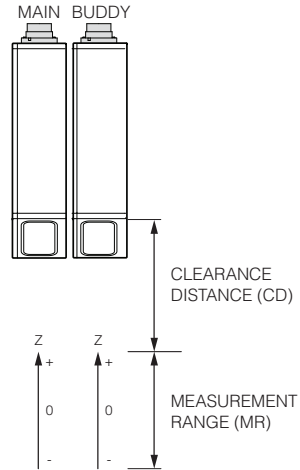

Main must be on the left side (when looking into the connector) of the Buddy (Wide)

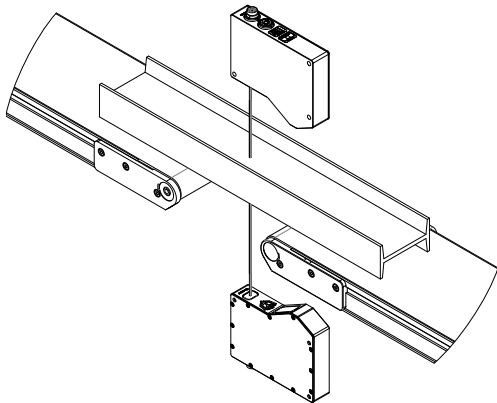

Above/below for two-sided measurement (Opposite)

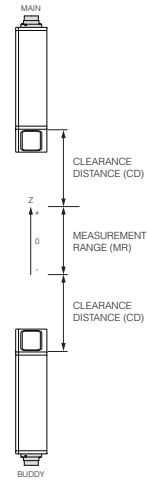

Main must be on the top with Buddy at the bottom (Opposite)

Software

User Interface Overview

Gocator sensors are configured by connecting to a *Main* sensor with a web browser. The Gocator web interface is illustrated below.

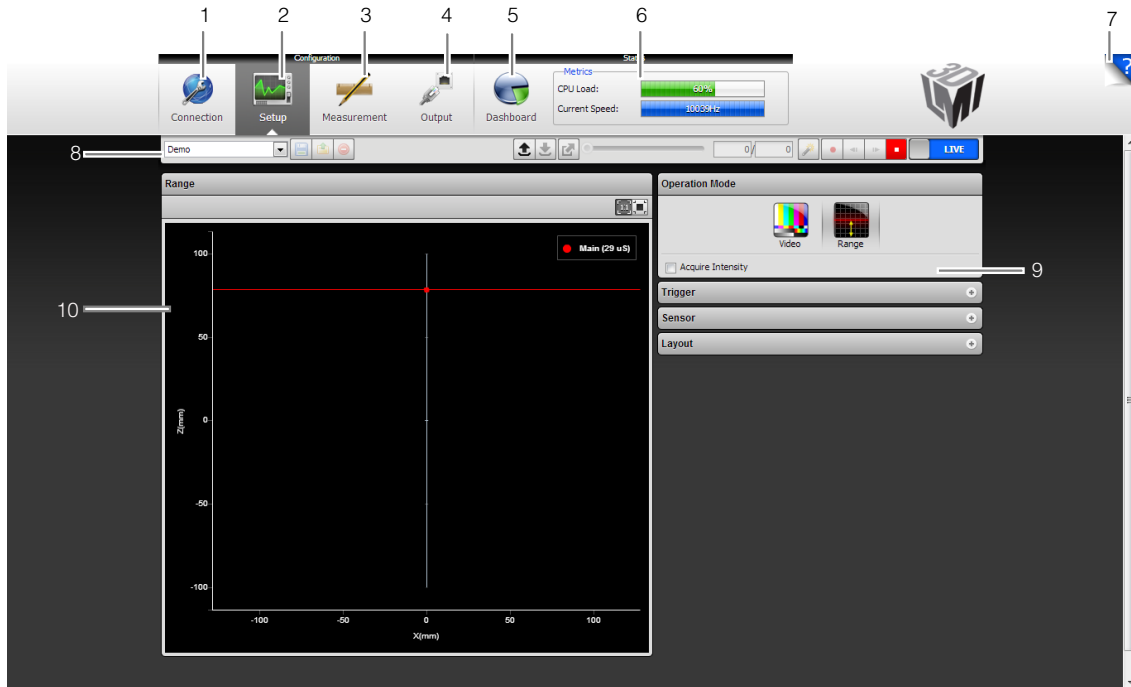

Element	Description
1	Connection Page For network configuration and maintenance.
2	Setup Page For configuring settings such as trigger source and exposure, and to perform calibration steps.
3	Measurement Page For configuring measurements.
4	Output Page For configuring measurement result outputs to external devices.
5	Dashboard Page For viewing performance statistics and results.
6	Metric Panel Summarizes important performance statistics.
7	Help Online help resources, including User Manual, Firmware updates, and SDK.
8	Toolbar Controls sensor operation, manages configurations and replays recorded measurement data.
9	Configuration Area Provides controls to configure ranging and measuring parameters.
10	Data Viewer Displays sensor data, tool setup controls, and measurements.

Connecting to a New Sensor

Sensors are shipped with the following default network configuration:

Setting	Default
DHCP	Disabled
IP Address	192.168.1.10
Subnet Mask	255.255.255.0
Gateway	0.0.0.0

All Gocator sensors are configured to 192.168.1.10 as the default IP address. For a dual sensor system, the Main and Buddy sensors must be assigned unique addresses before they can be used on the same network. Prior to proceeding, connect the Main and Buddy sensors one at a time (to avoid an address conflict) and use the steps on page 37 to assign each sensor a unique address.

To connect to a sensor for the first time:

1 Connect cables and apply power.

Sensor cabling is illustrated in System Overview (page 15)

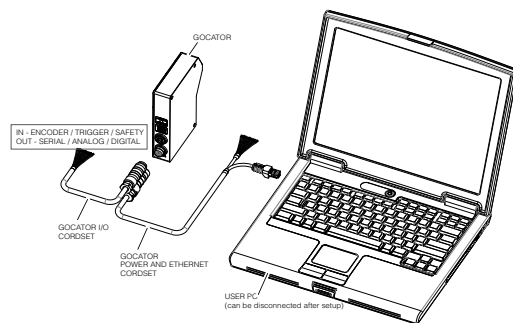

2 Change client network settings.

Windows 7:

- » Open the Control Panel and select Network and Sharing Center, then click Change Adapter Settings.
- » Right-click the desired network connection, and then click Properties.
- » On the Networking tab, click Internet Protocol Version 4 (TCP/IPv4), and then click Properties.
- » Select “Use the following IP address” option.
- » Enter IP Address “192.168.1.5” and Subnet Mask “255.255.255.0”, then click OK.

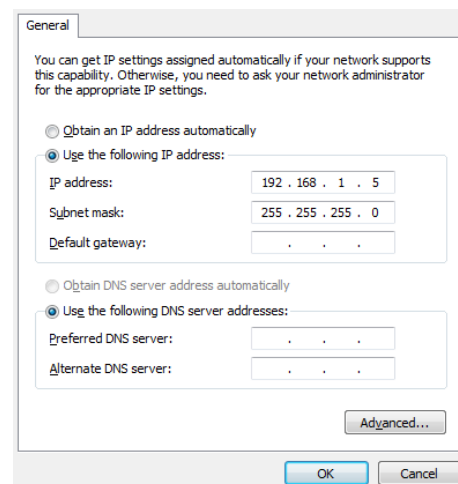

Mac OS X v. 10.6:

- » Open the Network Pane in System Preferences and select Ethernet.
- » Set Configure to “Manually”.
- » Enter IP Address “192.168.1.5” and Subnet Mask “255.255.255.0”, then click Apply.

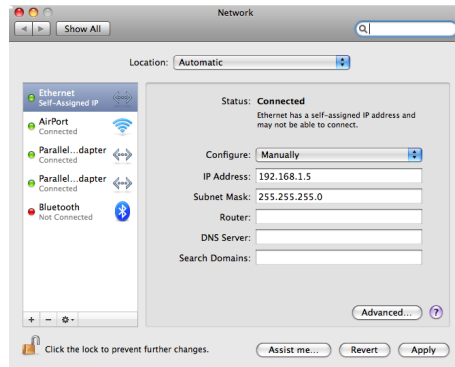

3 Enter the sensor's IP address 192.168.1.10 in a web browser.

Firefox 3.5+, Chrome 4.0+, and Internet Explorer 8.0+ are supported. IMPORTANT! The Adobe Flash browser plug-in, version 10.0+, must be installed.



4 Select the language

After selecting the language, the browser will refresh and the web interface will display in the selected language.

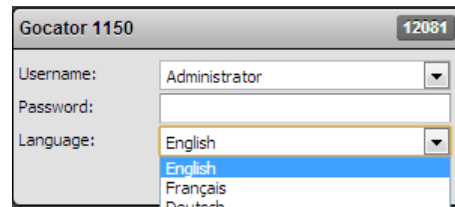

5 Press the Login button.

The Administrator password is initially blank.

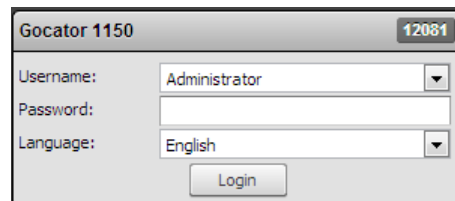

Refer to Troubleshooting (page 187) if you experience any problems while attempting to establish a connection to the sensor.

Running for the First Time

The Gocator is shipped with a default configuration that will produce laser ranges on most targets. The following sections walk through the steps required to setup the sensor(s) to produce laser ranges.

Running a Standalone Sensor System

After the sensor is installed, laser ranging can be exercised to verify basic sensor operation.

To run a sensor for the first time:

1 Power up the sensor.

The power LED (blue) should turn on immediately.

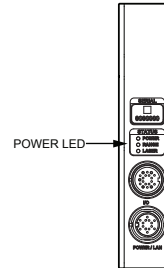

2 Enter the sensor's IP address 192.168.1.10 in a web browser.



3 Login as Administrator with no password.

The interface display language can be changed using the language option. After selecting the language, the browser will refresh and the web interface will display in the selected language.

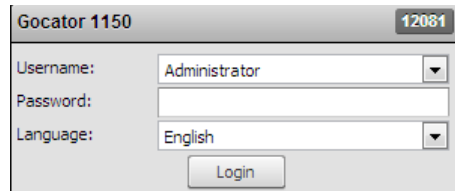

4 Select the Connection Page.



5 Specify the Connect To setting.

The Connect To setting specifies whether the sensor system is standalone, connected to a Master 100 or a Master 400/800/1200/2400. For single sensor operations select Standalone or Master 100.

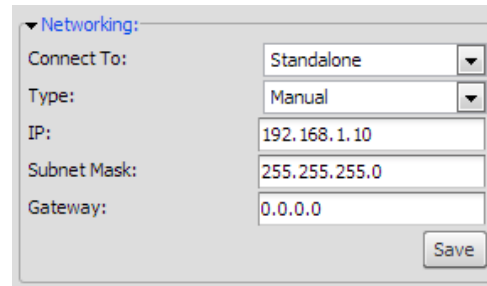

6 Ensure that the Data Source selector is showing LIVE.

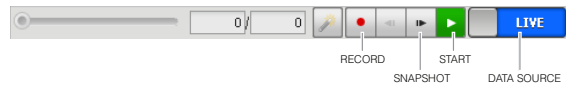

7 Ensure that the Laser Safety Switch is enabled or the Laser Safety input is high.

8 Select the Setup Page.

9 Press the Start button to start the sensor.

The Start button is used to run sensors continuously, while the Snapshot button is used to trigger a single capture.

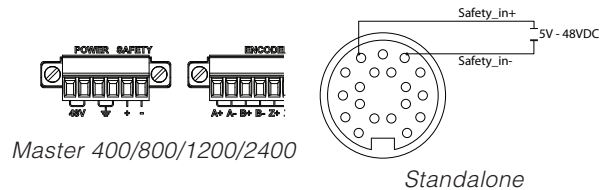

10 Move a target into the laser plane.

If a target object is within the sensor's measurement range, the Data Viewer will display the distance to the target and the sensor's range indicator LED will illuminate.

If you cannot see the laser, or if a range is not displayed in the Data Viewer, refer to Troubleshooting (page 187).

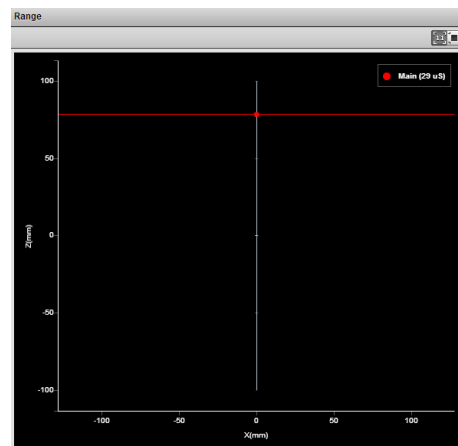

11 Press the Stop button.

You should now see the laser turns off.

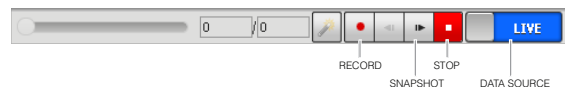

Running a Dual Sensor System

After the sensors are installed, laser ranging can be exercised to verify basic sensor operation.

To run a dual sensor setup for the first time:

1 Turn off the sensors and unplug the Ethernet network connection of the Main sensor.

All sensors are shipped with a default IP address of 192.168.1.10. Ethernet networks require a unique IP address for each device. Skip step 1 to 3 if the Buddy sensor's IP address is already setup with a unique address.

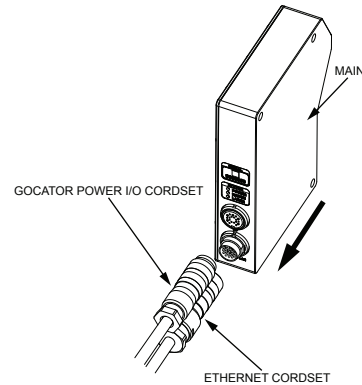

2 Power up the Buddy sensor.

The power LED (blue) of the buddy sensor should turn on immediately.

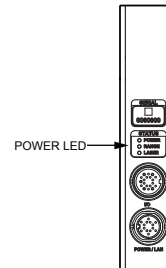

3 Enter the sensor's IP address 192.168.1.10 in a web browser.

This will log into the Buddy sensor.



4 Login as Administrator with no password.

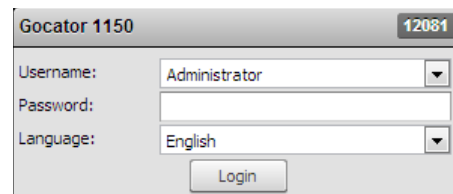

5 Select the Connection Page.



6 Modify the IP address to 192.168.1.11 in the Network settings and click the Save button.

When you click the Save button, you will be prompted to confirm your selection.

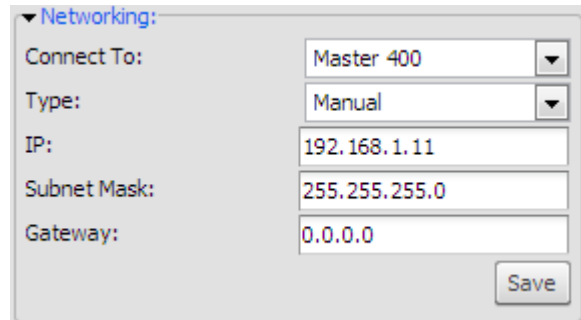

7 Turn off the sensors, re-connect the Main sensor's Ethernet connection and power-cycle the sensors.

After changing network configuration, the sensors must be reset or power-cycled before the change will take effect.

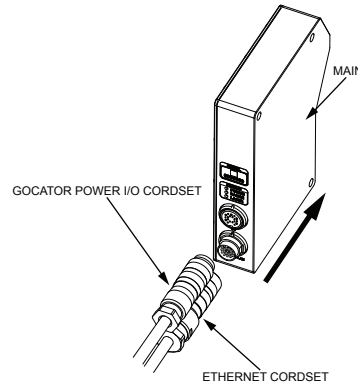

8 Enter the sensor's IP address 192.168.1.10 in a web browser.

This will log into the Main sensor.



9 Login as Administrator with no password.

The interface display language can be changed using the language option. After selecting the language, the browser will refresh and the web interface will display in the selected language.

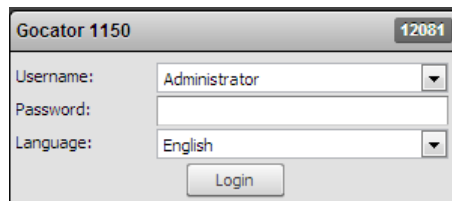

10 Select the Connection Page.



11 Specify the Connect To setting.

The Connect To setting specifies whether the sensor system is standalone or connected to a Master 400/800/1200/2400. For dual sensor operation select Master 400/800/1200/2400.

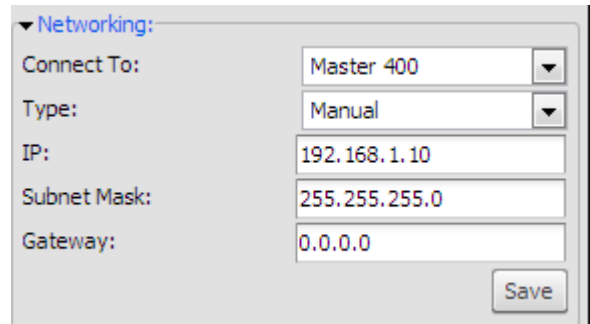

12 Go to Connection Page > Available Sensors panel.

The serial number of the Buddy sensor is listed in the Available Sensors panel.

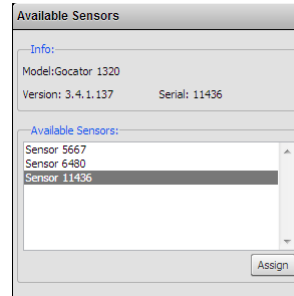

13 Select the Buddy sensor. Click the Assign button.

The Buddy sensor will be assigned to the Main sensor and its status will be updated in the System panel

The firmware on Main and Buddy sensors must be the same for Buddy assignment to be successful. If the firmware is different, connect the Main and Buddy sensor one at a time and follow the steps in Firmware Upgrade (page 112) to upgrade the sensors.

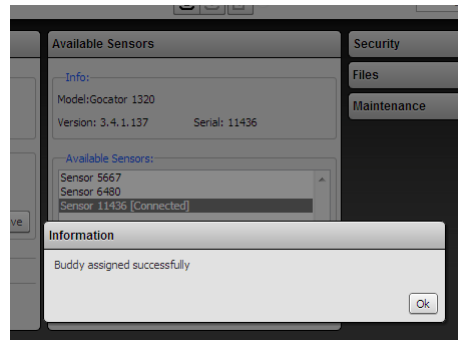

14 Ensure that the Data Source selector is showing LIVE.



15 Ensure that the Laser Safety Switch is enabled or the Laser Safety input is high.

16 Select the Setup Page.

17 Press the Start button to start the sensors.

The Start button is used to run sensors continuously, while the Snapshot button is used to trigger a single measurement.

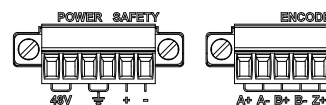

Master 400/800/1200/2400

18 Move a target into the laser plane.

If a target object is within the sensor's measurement range, the Data Viewer will display the distance to the target and the sensor's Range Indicator LED will illuminate.

Click the Main and Buddy button under the Setup Page to view the range data from the main and buddy sensor

If you cannot see the laser, or if a range is not displayed in the Data Viewer, refer to Troubleshooting (page 187).

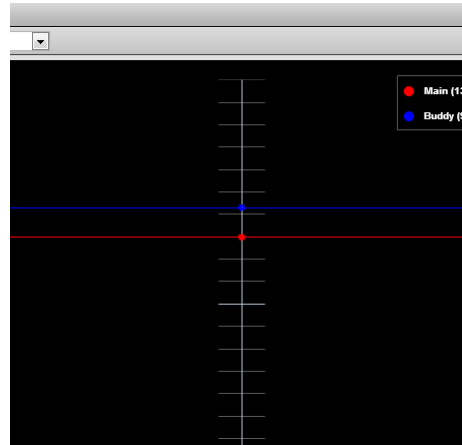

19 Press the Stop button.

You should now see the lasers turn off.

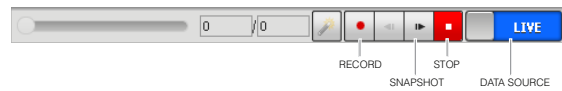

Next Steps

After completing the steps in this chapter, the Gocator measurement system is ready to be configured for an application using the software interface. The interface is explained in the following chapters:

Setup and Calibration (page 42)

Fine tunes laser ranging for an application.

Measurement (page 67)

Programs measurements on sensors that are equipped with *measurement tools*.

Output (page 82)

Range data, measurements, and Pass/Fail results can be transmitted to external devices for process control or data analysis.

Toolbar (page 94)

Controls system operation, record and playback data, and manages sensor configurations.

Dashboard (page 100)

Provides real-time monitoring of its health and measurement results.

Connection and Maintenance (page 104)

Setups the sensor connections, networking and performs maintenance tasks.

Setup and Calibration

Setup Page

This chapter describes the steps to configure Gocator sensors for laser ranging using the Setup Page. Setup and calibration steps should be performed before programming measurements or outputs.

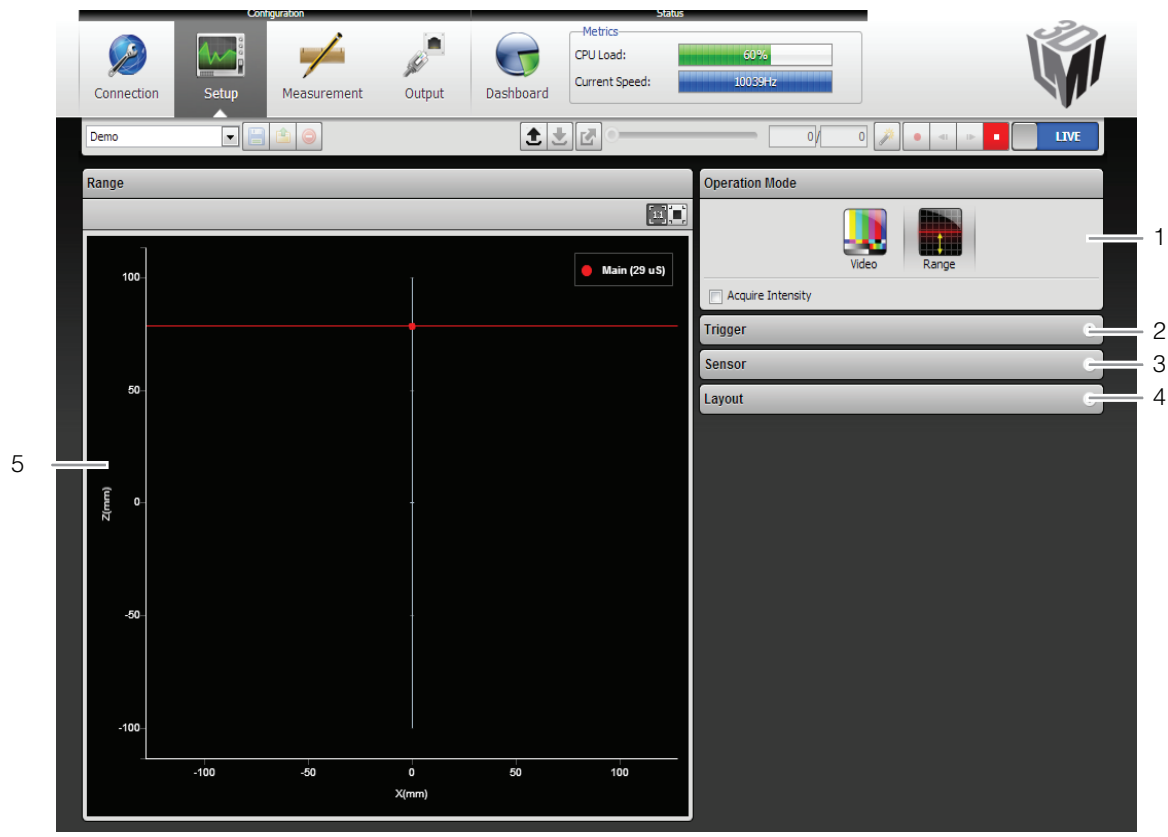

Element	Description
1	Operation Mode Panel Use the Operation Mode panel to set the current operation mode (Video or Range) and other options.
2	Trigger Panel Use the Trigger panel to specify the trigger source and trigger related settings.
3	Sensor Panel Use the Sensor panel to specify settings for an individual sensor, such as active area or exposure.
4	Layout Panel Use the Layout panel to configure the dual sensor system and to perform alignment or travel calibration.
5	Data Viewer Use the Data Viewer to display sensor data and adjust regions of interest. Depending on the current operation mode, the data viewer can display video images or range plots.

The following table provides quick references for specific goals that users could achieve from the panels in the setup page.

Goal	References
1 Select a trigger source that is appropriate for the application.	Trigger (page 51)
2 Ensure that camera exposure is appropriate for laser ranging.	Exposure (page 58)
3 Find the right balance between range quality, speed, and CPU utilization.	Active Area (page 56) Exposure (page 58)
4 Specify mounting orientations for dual sensor systems.	Dual Sensor System Layout (page 62)
5 Calibrate the system so that laser range data can be aligned to a common reference and values can be correctly scaled in the axis of motion.	Alignment Calibration (page 64) Travel Calibration (page 65)

Operation Modes

The Gocator web interface supports two *operation modes*: Video and Range. The operation mode can be selected in the Operation Mode panel.

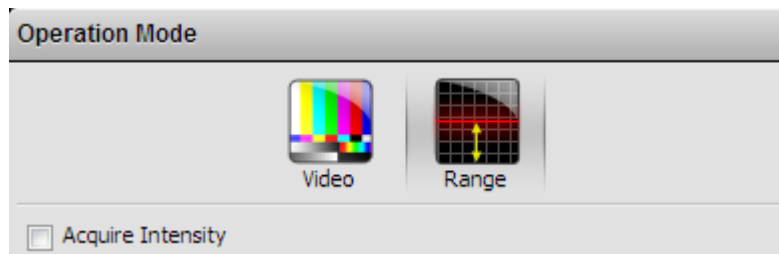

Mode and Option	Description
Video	Output video images from the Gocator. This mode is useful for configuring exposure time and troubleshooting stray light or ambient light problems.
Range	Output ranges and perform measurements. Video images are processed internally to produce laser ranges and measurements.
Acquire Intensity	When enabled, an intensity value will be produced for each laser range.

Data Viewer

The Data Viewer can display video images, range plots and intensity images. It is also used to configure active area and measurement tools. Its use is dependent on the current operation mode and the panel selection.

Video Mode

The Data Viewer displays camera images. In a dual sensor system, camera images from the Main or the Buddy sensor can be displayed.

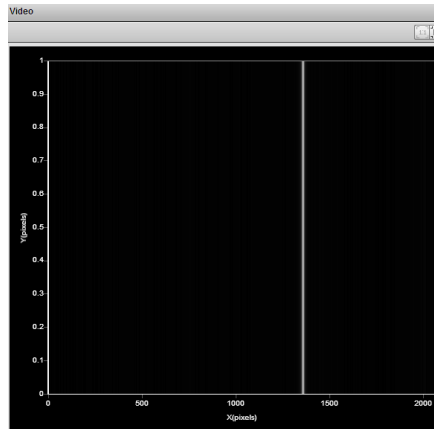

To select the view of the display:

1 Navigate to the Setup Page.

2 Select the View.

Select the Main or the Buddy sensor from the drop-down list at the top of the Data Viewer.

Range Mode

In range mode, the Data Viewer displays ranges.

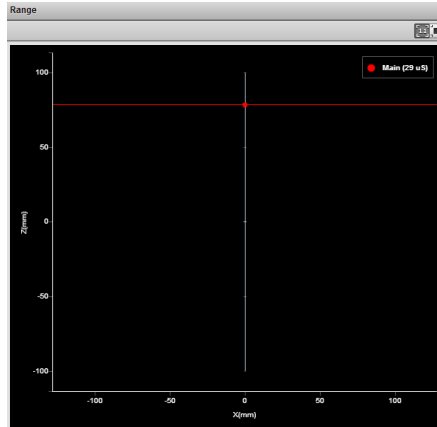

In a dual sensor system, ranges from individual sensors or from a combined view can be displayed. While in the Setup Page, selecting a panel (e.g. Sensor Panel or Layout Panel) will automatically set the display to the most appropriate display view.



To manually select the display view in the Setup Page:

1 Navigate to the Setup Page.

2 Select the View.

An individual sensor or the combined view can be selected from the drop-down list at the top of the Data Viewer.

In the Measurement Page, the view of the display is set to the Range Source of the selected measurement tool (page 71).

Region Definition

The Data Viewer can also be used to define a region of interest.

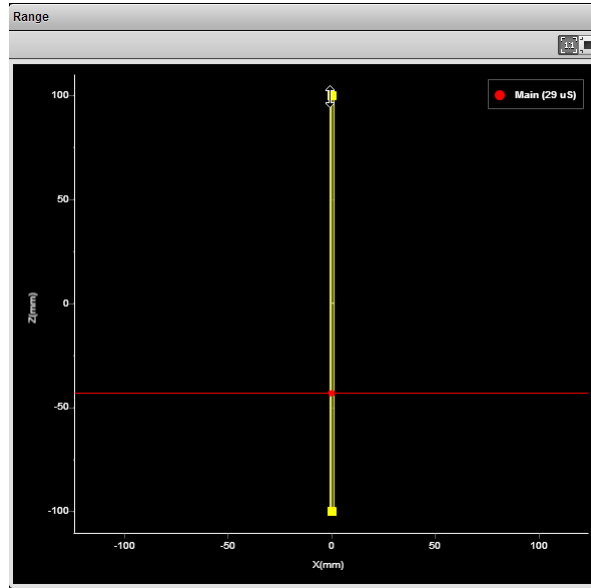

To setup a region of interest:

1 Move the mouse cursor to the rectangle.

The rectangle is automatically displayed when a setup or measurement requires an area to be specified.

2 Drag the rectangle to move it, and use the handles on the rectangle's border to resize it.

Data Viewer Controls

The data viewer is controlled the icons on the display tool bar. The mouse wheel can be also be used for zooming.

Press 'F' when the cursor is in the data view to change into full screen.

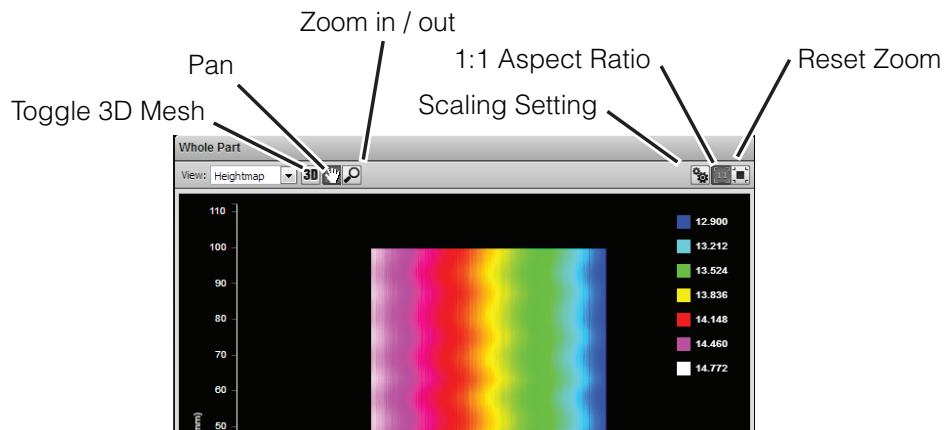

Range Output

Gocator measures the height of the object calculated from laser triangulation. The measurement is referred to as ranges and is reported as the distance from the sensor origin.

Coordinate Systems

Range data is reported in sensor or system coordinates depending on the calibration state. The coordinate systems are described below.

Sensor Coordinates

Prior to calibration, individual sensors use the coordinate system shown here.

The *z-axis* represents the sensor's measurement range (MR), with the values increasing towards the sensor.

The origin is at the center of the MR.

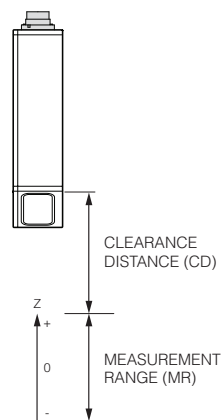

System Coordinates

Alignment calibration or travel calibration can be used to establish a common coordinate system for the Main and Buddy sensors. System coordinates are aligned such that the system Z-origin is set to the base of the calibration target object.

For Wide and Opposite layouts, ranges and measurements from the Main and Buddy sensors are expressed in a unified coordinate system. Isolated layouts express results using a separate coordinate system for each sensor.

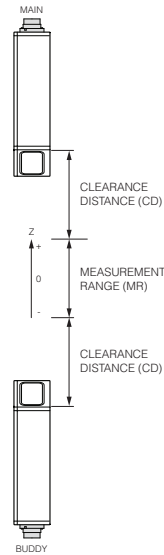
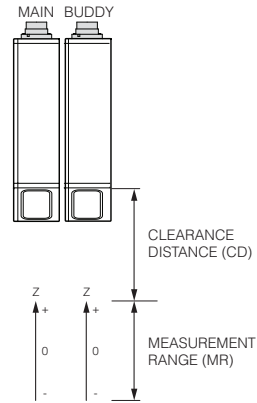

Intensity Output

Gocator sensors can produce intensity data that measure the amount of light reflected by an object. An 8-bit intensity value is output for each range value along the laser line.

Trigger

A trigger is an event that causes a sensor to take a single picture. When a trigger is processed, the laser is strobed and the camera exposes to produce an image. The resulting image is processed inside the sensor to yield a *laser range* (distance information), which can then be used for measurement.

The laser and camera inside a sensor can be triggered by one of four sources:

Trigger Source	Description
Time	Sensors have an internal clock that can be used to generate fixed-frequency triggers. The external input can be used to enable or disable the time triggers.
Encoder	<p>An encoder can be connected to provide triggers in response to motion. Three encoder triggering behaviors are supported:</p> <ol style="list-style-type: none"> 1. Ignore Backward <p>A scan is triggered only when the target object moves forward. If the target object moves backward, it must move forward by at least the distance of one encoder spacing to trigger a scan.</p>

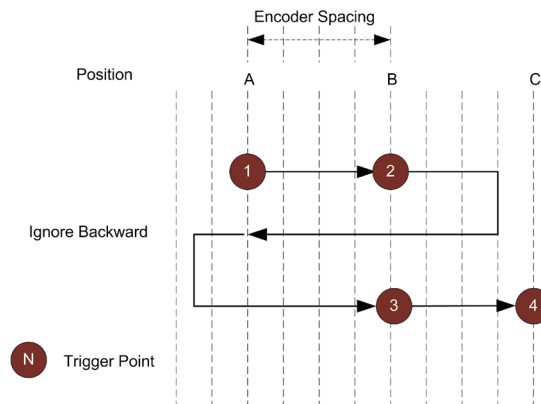

2. Track Backward

A scan is triggered when the target object moves forward. If the target object moves backward, it must move forward by at least the distance that the target travelled backward, plus one encoder spacing, to trigger a scan.

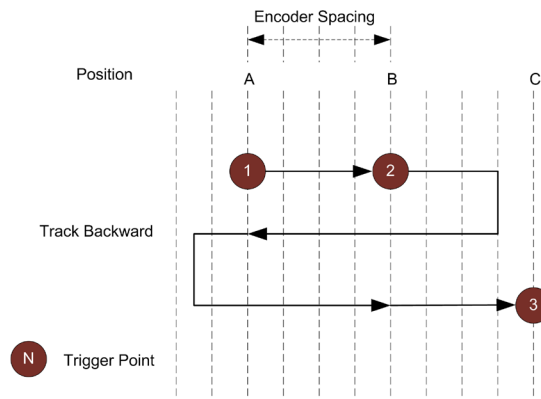

Trigger Source	Description
Encoder	<p data-bbox="435 193 606 221">3. Bi-directional</p> <p data-bbox="435 233 1202 262">A scan is triggered when the target object moves forward or backward.</p> <div data-bbox="643 294 1187 695" data-label="Diagram"> </div> <p data-bbox="435 737 1361 818">When triggers are received at a frequency higher than the maximum frame rate, some triggers may not be accepted. The <i>Trigger Drops Indicator</i> in the Dashboard can be used to check for this condition.</p> <p data-bbox="435 834 1225 862">The external input can be used to enable or disable the encoder triggers.</p> <p data-bbox="435 874 1353 929">Refer to Encoder Input (page 234) for more information on connecting the encoder to Gocator sensors.</p>
External Input	<p data-bbox="435 947 1315 975">A digital input can provide triggers in response to external events (e.g. photocell).</p> <p data-bbox="435 987 1361 1068">When triggers are received at a frequency higher than the maximum frame rate, some triggers may not be accepted. The <i>Trigger Drops Indicator</i> in the Dashboard can be used to check for this condition.</p> <p data-bbox="435 1084 1361 1139">Refer to Digital Inputs (page 234) for more information on connecting external input to Gocator.</p>
Software	<p data-bbox="435 1155 1369 1209">A network command can be used to send a software trigger. Refer to Gocator Protocol (page 124) for more information.</p>

Examples

Example: Encoder + Conveyor

Encoder triggering is used to perform range measurements at a uniform spacing.

The speed of the conveyor can vary while the object is being measured; an encoder ensures that the measurement spacing is consistent, independent of conveyor speed.

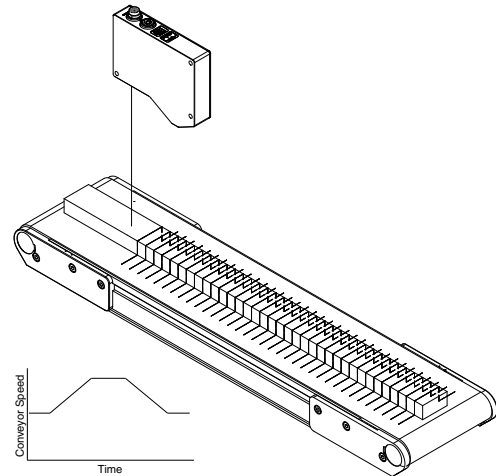

Example: Time + Conveyor

Time triggering can be used instead of encoder triggering to perform range measurements at a fixed frequency.

Measurement spacing will be non-uniform if the speed of the conveyor varies while the object is being measured.

It is strongly recommended to use an encoder with transport-based systems due to the difficulty in maintaining constant transport velocity.

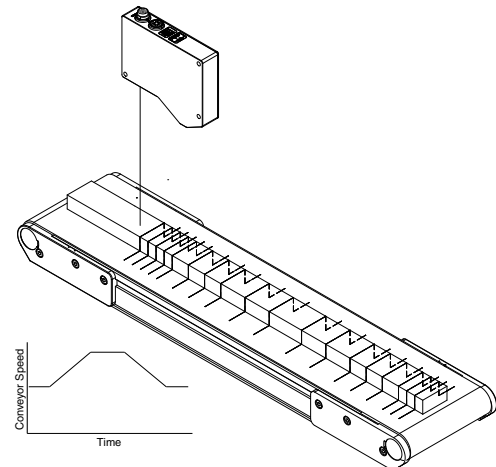

Example: External Input + Conveyor

External Input triggering can be used to produce a snapshot for range measurement.

For example, a photocell can be connected as an External Input to generate a trigger pulse when a target object has moved into position.

An External Input can also be used to gate the trigger signals when Time or Encoder triggering is used. For example, a photocell could generate a train of trigger pulses as long as there is a target in position.

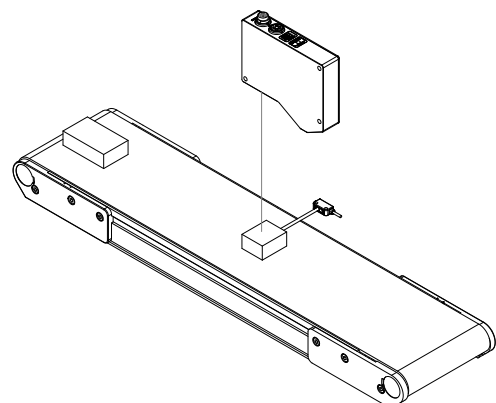

Example: Software Trigger + Robot Arm

Software triggering can be used to produce a snapshot for range measurement.

A software trigger can be used in systems that employ external software to orchestrate the activities of system components.

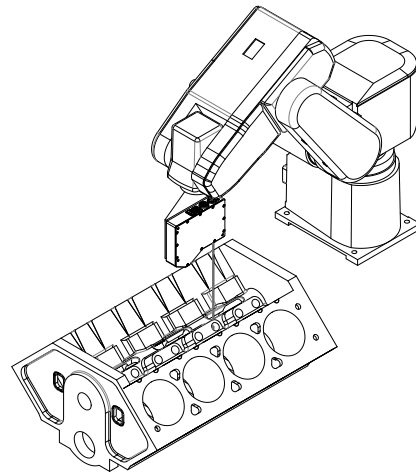

Settings

The trigger source is selected using the Trigger panel in the Setup page.

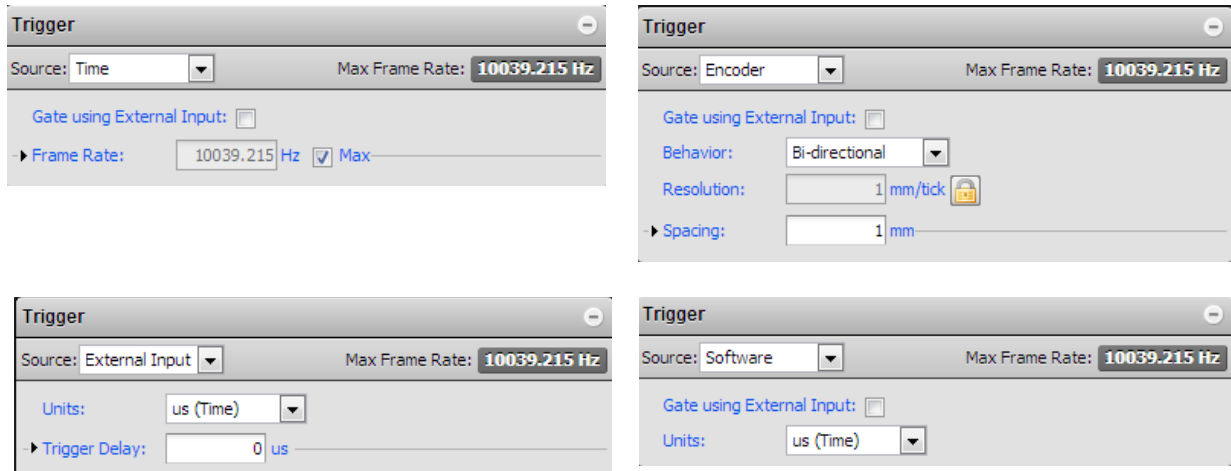

After specifying a trigger source, the Trigger Panel will show the parameters that can be configured.

Parameters	Trigger Source	Description
Trigger	All	Selects the trigger source. (Time, Encoder, External Input, or Software)
Max Frame Rate	All	Reports the maximum frame rate, which is a function of the current Active Area, Exposure, and Resolution settings.
Frame Rate	Time	The Frame Rate setting can be used to control the frame rate. Select the Max check box to lock to the maximum frame rate. Fractional values are supported. For example, 0.1 can be entered to run at 1 frame every 10 seconds.
Gate using External Input	Time, Encoder	External input can be used to enable or disable ranging in a sensor. When enabled, the sensor will respond to time or encoder triggers only when the external input is asserted. Refer to Digital Inputs (page 234) for more information on connecting external input to a Gocator sensor.
Encoder Behavior	Encoder	Encoder Behavior setting is used to specify how the Gocator sensor is triggered when the target moves.
Encoder Resolution	Encoder	Encoder Resolution (millimeters per tick) provides proper scaling in the y-axis (axis of motion). The encoder resolution can be calculated automatically by performing Travel Calibration or set manually after clicking on the unlock button.
Spacing	Encoder	Encoder Spacing setting is used to specify the distance between triggers (mm). Internally the Gocator sensor rounds the spacing to a multiple of the encoder resolution.
Units	External Input, Software	Units specifies whether the trigger delay, output delay and output scheduled command operates in the time or the encoder domain. The unit is implicitly set to microseconds with Time trigger source, and millimeters with Encoder trigger source.
Trigger Delay	External Input	Trigger delay can be used to control the time or spacing the sensor waits before a frame after the external input is activated. This is used to compensate for the positional difference between the source of the external input trigger (e.g. photocells) and the sensor. Trigger delay is only supported in the single exposure mode (page 58).

Active Area

Active area refers to the region within the sensor's maximum field of view that is used for laser ranging.

By default, the active area covers the sensor's entire field of view. Users can reduce the active area.

Active area is specified in sensor coordinates, rather than system coordinates. As a result, active area must be configured before Alignment or Travel calibration is performed. Refer to Coordinate Systems (page 48) for more information on sensor and system coordinates.

 Active Area can only be set when the sensor is not calibrated.

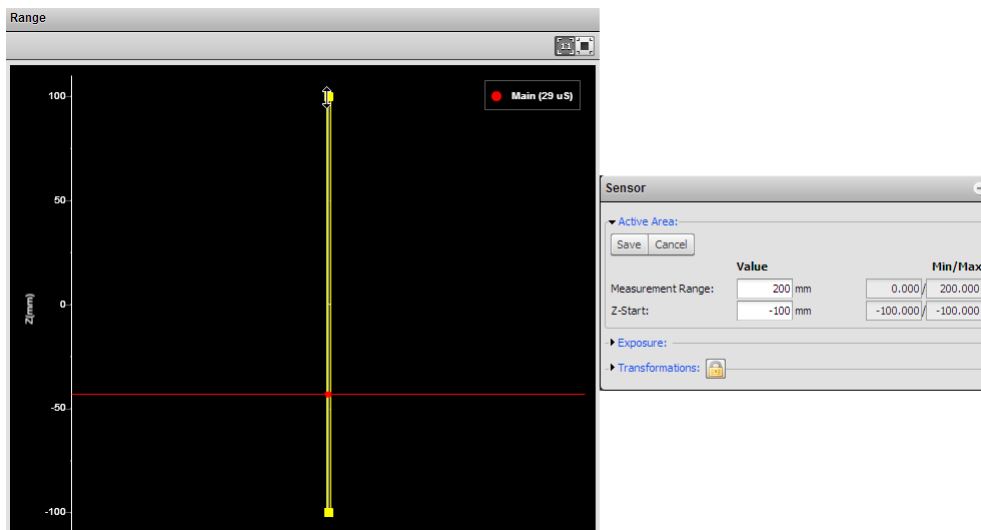
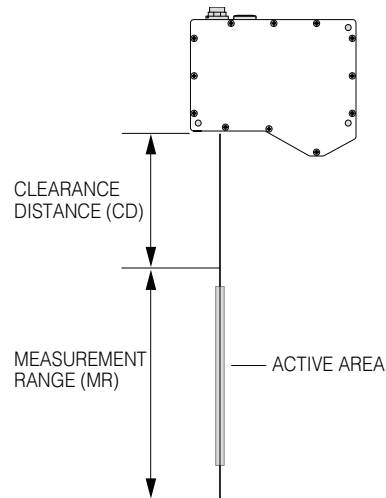

To set the active area:

1 Navigate to the Sensor panel.

Active area is specified separately for each sensor. Click the arrow next to Active Area to expand the panel.

2 Click the Select button.

If the Select Active Area button is disabled, then calibration may need to be cleared. Refer to Clearing Calibration (page 66) in this chapter for information on clearing calibration.

3 Position and resize the Active Area rectangle shown in the Data Viewer.

4 Click the Save button.



Laser ranging devices are usually more accurate at the near end of the measurement range. If your application requires a measurement range that is small relative to the maximum measurement range of the sensor, mount the sensor such that the active area can be specified at the near end of the measurement range.

Exposure

Exposure determines the duration of camera and laser on-time. Longer exposures can be helpful to detect laser signals on dark or distant surfaces, but increasing exposure time decreases the maximum speed. Different target surfaces could require different exposures for optimal results. Gocator sensors provide two exposure modes for the flexibility needed to scan different types of target surfaces.

Exposure Mode	Description
Single Exposure	Uses single exposure for all objects. Used when the surface is uniform and is the same for all targets.
Dynamic Exposure	Automatically adjust the exposure after each frame. Used when the target surface varies between scans.

Video mode enables you to see how the laser appears on the camera and to identify any stray light or ambient light problems. When exposure is tuned correctly, the laser line should be clearly visible in the viewer. If it is too dim, increase the exposure value; if it is too bright decrease exposure value.

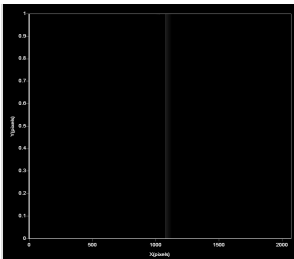

Under exposure

Laser point is not detected.
Increase the exposure value.

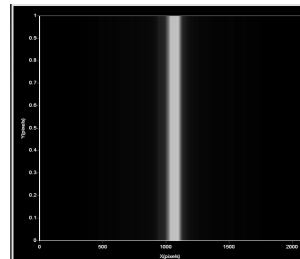

Over exposure

Laser point is too bright.
Decrease the exposure value.

In a dual sensor system, the Main and the Buddy sensor must use the same exposure mode or the system will fail to start.

Single Exposure

The sensor uses a fixed exposure in every scan. This is used when the target surface is uniform and is the same for all targets.

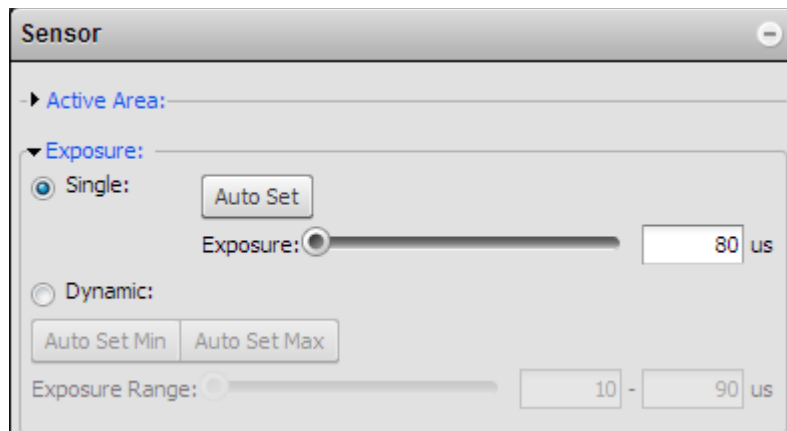

To enable single exposure:

1 Place a representative target in view of the sensor.

The target surface should be similar to the material that will normally be measured.

2 Select Range Mode.

3 Navigate to the Sensor panel.

Click the arrow next to Exposure to expand the panel. Click the Main or Buddy sensor button to select the sensor.

4 Select Single.

5 Edit the Exposure setting.

The auto-set function can be used to automatically tune the exposure. Press the Auto Set button and the sensor will turn on and automatically tune the exposure time.

6 Run the sensor and check that laser ranging is satisfactory.

If not satisfactory, adjust the exposure values manually. Switch to Video mode to use video to help tune the exposure.

Dynamic Exposure

The sensor automatically uses past range information to adjust the exposure to yield the best range. This is used when the target surface changes from scan to scan.

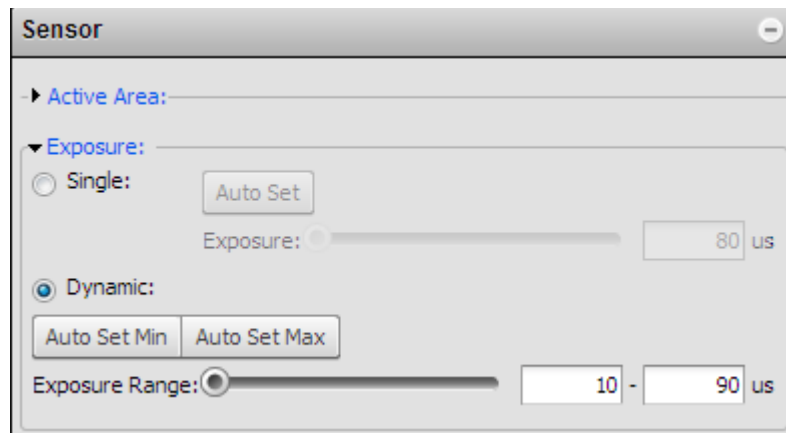

To enable dynamic exposure:

1 Select Range Mode.

2 Navigate to the Sensor panel for the Main or Buddy sensor.

Click the arrow next to Exposure to expand the panel. Click the Main or Buddy button to select the sensor.

3 Select Dynamic.

4 Set the minimum and maximum exposure.

The auto-set function can be used to automatically set the exposure. First, place the brightest target in the field of view and press the Auto Set Min button to set the minimum exposure. Then, place the darkest target in the field of view and press the Auto Set Max button to set the maximum exposure.

5 Run the sensor and check that laser ranging is satisfactory.

If not satisfactory, adjust the exposure values. Switch to Video mode to use video to help tune the exposure.

Transformations

The transformation settings are used to control how ranges are converted from sensor coordinates to system coordinates.

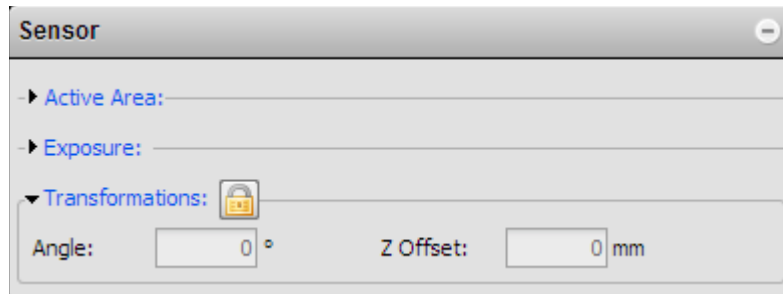

Element	Description
Z Offset	Specifies the shift along the z-axis. A positive value shifts the range towards the sensor.
Angle	Specifies the angle of the sensor to the target.

When applying the transformations, Angle is applied before the Z offset.

To configure transformation settings:

- 1 Select the Range Mode.**
- 2 Navigate to the Sensor panel.**
Click the arrow next to Transformation to expand the panel. Click the Main or Buddy button to select the sensor. Transformations can be configured separately for each sensor (click the arrow next to Transformations to expand the settings).
- 3 Click the unlock button to make the fields editable.**
- 4 Set the parameter values.**
- 5 Check that the transformation settings are applied correctly after ranging is restarted.**





Dual Sensor System Layout

Mounting orientations need to be specified for a dual sensor (Buddy) system. This information allows the Alignment or Travel Calibration procedures to determine the correct system-wide coordinates for laser ranging and measurements. Refer to Coordinate Systems (page 48) in this chapter for more information on sensor and system coordinates.

To specify the layout, navigate to the Layout panel on the Setup Page:

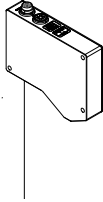

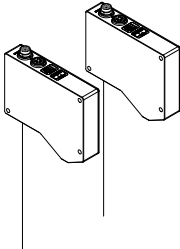
Supported Orientations

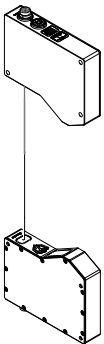
Orientation	Example
	
	
	

Calibration

Although Gocator sensors are pre-calibrated and ready to deliver ranges out of the box, calibration procedures are required to compensate for sensor mounting inaccuracies, to align multiple sensors into a common coordinate system, and to determine the resolution (with encoder) and speed of the transport system.

Gocator sensors support two types of calibration procedures: *Alignment Calibration* and *Travel Calibration*. Travel calibration performs essentially the same role as alignment calibration, but calibrates encoder resolution and y-axis offsets in addition to the corrections provided by alignment calibration.

Once calibration has been completed, the values derived will be saved automatically and reloaded each time the sensor is reset or powered up.

Calibration States

A Gocator can be in one of three calibration states: None, Manual, or Auto.

Calibration States

State	Explanation
None	Sensor has no calibration. Ranges are reported in default sensor coordinates.
Manual	User has manually edited transformations or encoder resolution.
Auto	Sensor is calibrated using either alignment or travel calibration.

An indicator on the Calibration panel will display CALIBRATED, MANUALLY CALIBRATED or NOT CALIBRATED.

Alignment vs. Travel Calibration

The table below summarizes the differences between alignment calibration and travel calibration.

Alignment Calibration vs. Travel Calibration

	Alignment Calibration	Travel Calibration
Target Type	Flat Surface or Cal Bar	Cal Bar
Target/Sensor Motion	Stationary	Linear Motion
Calibrates z-axis Offset	Yes	Yes
Calibrates Encoder	No	Yes

Refer to Coordinate Systems (page 48) for definitions of coordinate axes. Calibration bar is described in Installation (page 25).

The procedures to perform alignment calibration or travel calibration are described in the next sections. After calibration, the coordinate system for laser ranges will change from Sensor Coordinates to System Coordinates.

Alignment Calibration

Alignment calibration can be used to compensate for mounting inaccuracies by aligning sensor data to a common reference surface (often a conveyor belt).

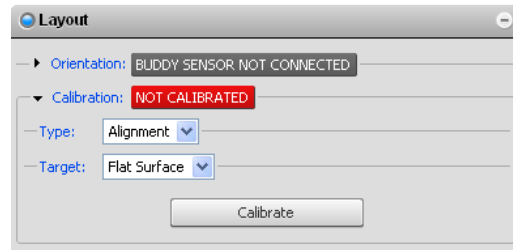

To perform alignment calibration:

1 Ensure that all sensors have a clear view of the target surface.

Remove any irregular objects from the sensor's field of view that might interfere with alignment calibration.

2 Navigate to the Layout panel and select Alignment Calibration.

Click the arrow button next to Calibration to expand the panel.

3 Clear the previous calibration if present.

Press the Clear Calibration button to remove the existing calibration.

4 Select a calibration Target.

Select *Flat Surface* to use the conveyor surface (or other flat surface) as the calibration reference, or *Bar* to use a custom calibration bar. If using a calibration bar, specify the bar dimensions. Refer to Installation (page 25) for more information.

5 Press the Calibrate button.

The sensors will start and the alignment calibration process will take place. Calibration is performed simultaneously for all sensors. If the sensors do not calibrate, check and adjust the exposure settings.

 Alignment calibration uses the exposure defined for the single exposure mode, regardless of the current exposure mode.

6 Use Range Mode to inspect calibration results.

Laser ranges from all sensors should now be aligned to the calibration target surface. The base of the calibration target (or target surface) provides the origin for the system z-axis.

 Alignment calibration does not automatically calibrate the resolution of the encoder (if present). However, these values can be manually entered if desired. Refer to Trigger (page 51) for more information.

Travel Calibration

Travel calibration can be used to achieve alignment calibration and motion calibration in a single procedure.

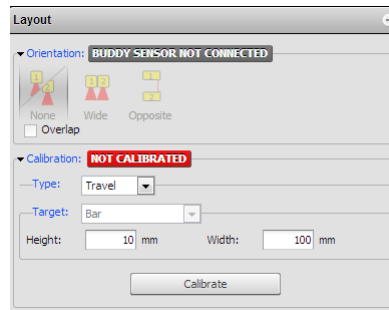

To perform travel calibration:

1 Place the calibration target prior to the laser plane.

Remove extraneous objects from the transport system such that the calibration target will be the only object that is scanned.

2 Navigate to the Layout panel and select Travel Calibration.

Click the arrow button next to Calibration to expand the panel.

3 Clear the previous calibration, if present.

Press the Clear Calibration button to remove the existing calibration.

4 Select a calibration Target.

Select *Bar* to use a custom-made calibration bar. Specify the bar dimensions. Refer to Installation (page 25) for more information.

5 Press the Calibrate button.

The sensors will start and then wait for the calibration target to pass through the laser plane.



Travel calibration uses the exposure defined for the single exposure mode, regardless of the current exposure mode.

6 Engage the transport system.

When the calibration target has passed completely through the laser plane, the calibration process will complete automatically. To properly calibrate the travel speed, the transport system must be running at the production operating speed before the target passes through the laser plane.

7 Use Range Mode to inspect calibration results.

Laser ranges from all sensors should now be aligned to the calibration target surface. The base of the calibration target (or target surface) provides the origin for the system z-axis.

Clearing Calibration

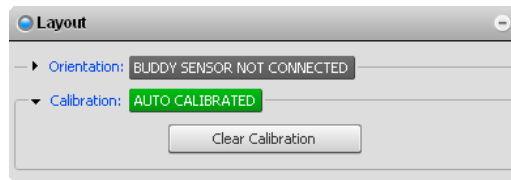

To clear calibration:

1 Navigate to the Calibration panel on the Setup page.

2 Click the Calibration or Clear Calibration button.

If the Clear Calibration button is pressed, the calibration will be erased and sensors will revert to using Sensor Coordinates.

Measurement

Measurement Page

Measurement tools are configured using the Measurement Page.

The content of the Measurement Page is controlled by the current operation mode. In Range Mode, the Measurement Page displays tools for range measurement. The Measurement page is disabled in Video mode.

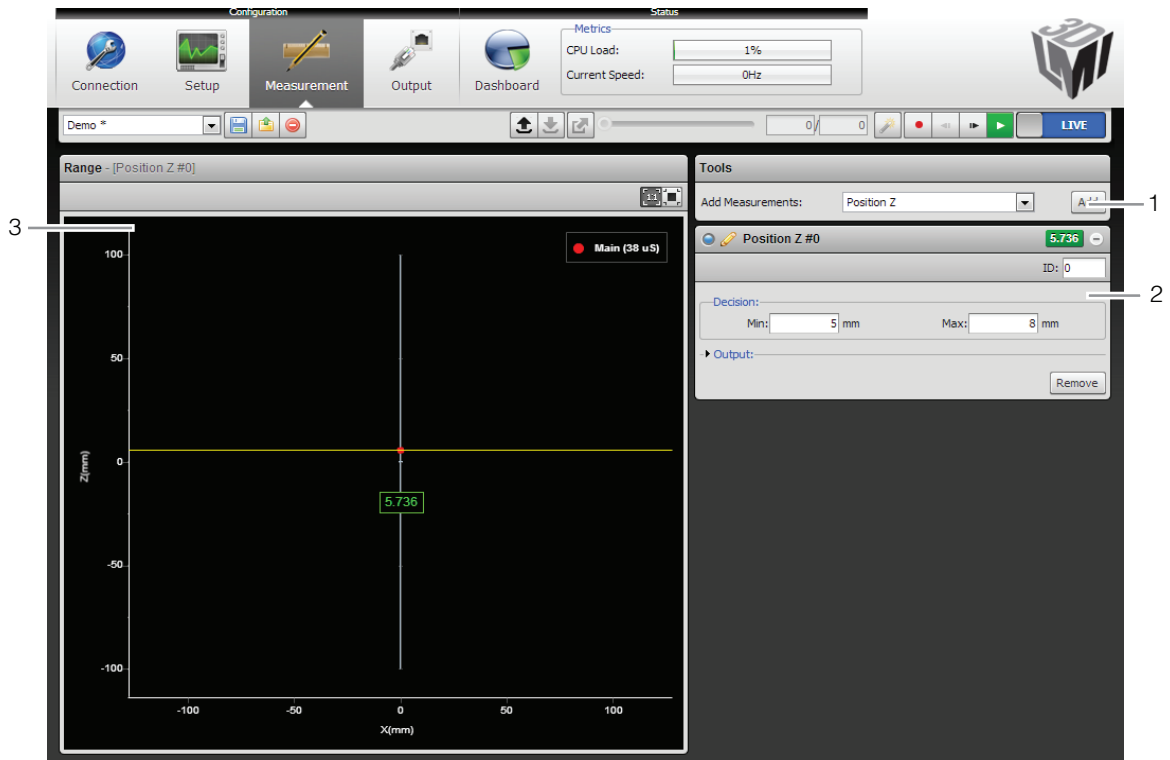

Element	Description
1	Tools Panel Use the Tools panel to add new measurements.
2	Measurement Panel For each measurement that is added, a configuration area will appear below the Measurements panel. Use this area to adjust settings for the measurement.
3	Data Viewer Displays laser range, setup tools and display result calipers related to the selected measurement.

Adding and Removing Measurements

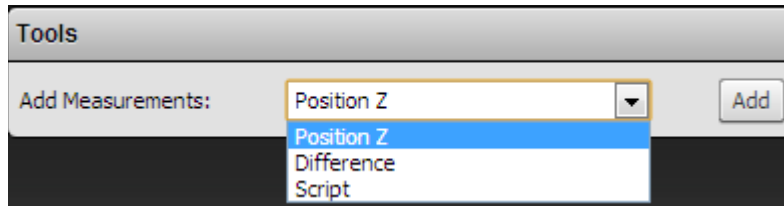

To add a new range measurement:

1 Select the desired measurement type.

Click on the item in the drop-down list next to Add Measurement to select the measurement type.

2 Press the Add button.

A configuration panel for the new measurement will be added to the bottom of the stack.

To remove a new range measurement:

1 Select the desired measurement.

Click on the title bar of the measurement to select it.

2 Click the Remove button.

The measurement will be removed from the list of measurements.

Changing the Measurement Name

Each measurement can be assigned a unique name. This allows multiple measurements of the same type to be distinguished in the web interface. The name is also referenced by the Script tool.



To edit a measurement name:

- 1 Click on the measurement name.**
- 2 Enter a new name.**
- 3 Press the Tab key.**

The name change will be completed when you press the Tab Key or click outside of the name edit field.

Measurement ID

Measurement ID is used to uniquely identify a measurement in the Gocator protocol or in the SDK. The value must be unique amongst all range measurements.



To edit a measurement ID:

1 Select a measurement.

Click on the + in a measurement panel to expand the panel.

2 Click on the measurement ID.

3 Enter a new number.

The value must be unique amongst all measurements.

4 Press the Tab key.

The name change will be completed when you press the Tab Key or click outside of the measurement ID edit field.

Range Sources

For dual sensor systems, measurements must specify a *range source*. The range source determines the data that will be used for the measurement.

The following options are available:

Range Source	Description
Main	Range data is provided by the Main sensor. This is the only option for standalone systems.
Buddy	Range data is provided by the Buddy sensor.
Both	Range data is provided by the Main and the Buddy sensor.

To select the range source:

1 Select a measurement.

Click on the + in a measurement panel to expand it.

2 Select the rangew Source.

Select the source in the drop down list. The drop down list will not appear if Main is the only option.

Decisions

Results from a measurement tool can be compared against minimum and maximum thresholds to generate *pass / fail decisions*. The decision state is *pass* (value displayed in green) if a measurement value is between the minimum and maximum threshold, otherwise the decision state is *fail* (value displayed in red).

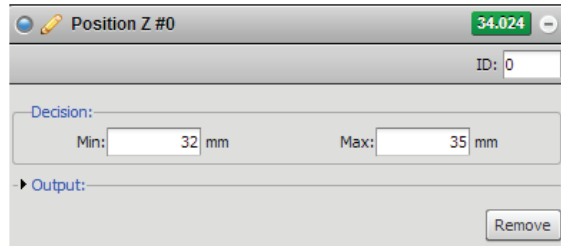

Value (34.024) is within the decision thresholds (Min:32, Max;35). Decision: Pass

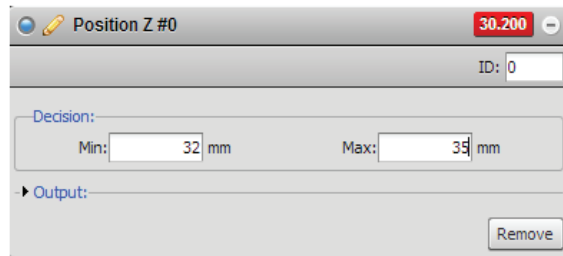
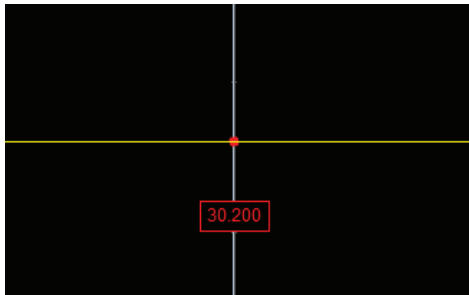

Value (30.200) is outside the decision thresholds (Min:32, Max;35). Decision: Fail

Along with measurement values, decisions can be sent to external programs and devices. In particular, decisions are often used in conjunction with digital outputs to trigger an external event in response to a measurement. Refer to Output (page 82) for more information on transmitting values and decisions.

Output Filters

Filters can be applied to measurement values before they are output from the Gocator sensors. Two filters are supported.

Operation	Description
Hold Last Valid	Hold the last valid value when the measurement is invalid. Measurement is invalid if there is no valid value.
Smoothing	Apply moving window averaging to reduce random noise in a measurement output. The averaging window is configured in number of samples (frames). If Hold Last Valid is enabled, smoothing uses the outputs from the Hold Last Valid filter.

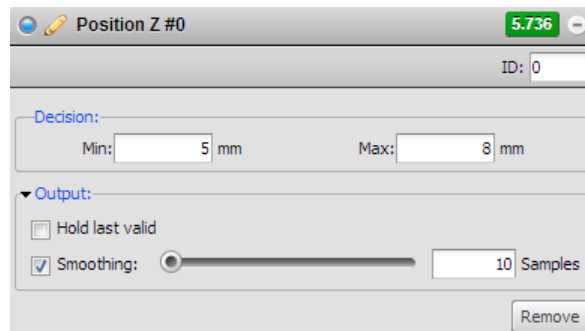

To configure the output filters:

1 Select a measurement.

Click on the + in a measurement panel to expand it. Click the arrow next to Output to expand the panel.

2 Enable filters and configure the settings.

Script Measurement

A Script measurement can be used to program a custom measurement using a simplified C-based syntax. Similar to other measurement tools, a script measurement can produce a measurement value and a measurement decision.

The following elements of the C language are supported:

Supported Elements

Elements	Supported
Control Operators	if, while, do, for, switch and return.
Data Types	char, int, unsigned int, float, double, long long (64-bit integer).
Arithmetic and Logical Operator	Standard C arithmetic operators, except ternary operator (i.e. "condition? trueValue: falseValue"). Explicit casting (e.g. int a = (int) a_float) is not supported.
Function Declarations	Standard C function declarations with argument passed by values. Pointers are not supported.

Built-in Functions

Measurement Functions

Measurement Functions	Descriptions
int Measurement_Exists(int id)	Tests for the existence of a measurement by ID. Parameters: id – Measurement ID Returns: 0 – measurement does not exist 1 – measurement exists
int Measurement_Valid(int id)	Retrieves the valid/invalid state of a measurement by its ID. Parameters: id - Measurement ID Returns 0 - Measurement is invalid 1 - Measurement is valid
long long Measurement_Value (int id)	Retrieves the value of a measurement by its ID. Parameters: id - Measurement ID Returns: Value of the measurement 0 – if measurement does not exist A measurement value is received as a fixed point integer with a scaling of 1/1000. For example, a 3.654mm value is received as 3654.
int Measurement_Decision (int id)	Retrieves the decision of a measurement by its ID. Parameters: ID - Measurement ID Returns: Decision of the measurement 0 – if measurement decision is false 1 – If measurement decision is true

int Measurement_NameExists(char *name)	Determines if a measurement exist by name. Parameter: name – name of a measurement Return: 0 – measurement does not exist 1 – measurement exists
int Measurement_Id (char *name)	Retrieves the measurement ID by the measurement name. Parameters: name – name of a measurement Returns: -1 – measurement does not exist Other – Measurement ID
void Output_Set (long long value, int decision)	Output a value and decision. Only the last output value / decision in a script run is kept and passed to the Gocator output. Parameters: value - value output by the script decision - decision value output by the script. Can only be 0 or 1

Memory Functions

Memory Functions	Descriptions
void Memory_Set64s (int id, long long value)	Stores a 64-bit signed integer in persistent memory. Parameters: id - ID of the value value - Value to store
long long Memory_Get64s (int id)	Retrieves a 64-bit signed integer from persistent memory. Parameters: id - ID of the value Returns: value - Value stored in persistent memory
void Memory_Set64u (int id, unsigned long long value)	Stores a 64-bit unsigned integer in the persistent memory Parameters: id - ID of the value value - Value to store
unsigned long long Memory_Get64u (int id)	Retrieves a 64-bit unsigned integer from persistent memory. Parameters: id - ID of the value Returns: value - Value stored in persistent memory
void Memory_Set64f (int id, double value)	Stores a 64-bit double into persistent memory. Parameters: id - ID of the value value - Value to store
double Memory_Get64f (int id)	Retrieves a 64-bit double from persistent memory. All persistent memory values are set to 0 when the sensor starts. Parameters: id - ID of the value Returns: value - Value stored in persistent memory

int Memory_Exists (int id)	Tests for the existence of a value by ID. Parameters: id – Value ID Returns: 0 – value does not exist 1 – value exists
void Memory_Clear (int id)	Erases a value associated with a ID. Parameters: id – Value ID
void Memory_ClearAll()	Erases all value from persistent memory

Stamp Functions

Stamp Functions	Descriptions
long long Stamp_Frame()	Retrieves the frame index of the current frame.
long long Stamp_Time()	Retrieves the time stamp of the current frame.
long long Stamp_Encoder()	Retrieves the encoder position of the current frame.
long long Stamp_EncoderZ()	Retrieves the encoder index position of the current frame.
unsigned int Stamp_Inputs()	Retrieves the digital input state of the current frame.

Math Functions

Math Functions	Descriptions
float sqrt(float x)	Calculates square root of x
float sin(float x)	Calculates sin(x) (x in radians)
float cos(float x)	Calculates cos(x) (x in radians)
float tan(float x)	Calculates tan(x) (x in radians)
float asin(float x)	Calculates asin(x) (x in radians)
float acos(float x)	Calculates acos(x) (x in radians)
float atan(float x)	Calculates atan(x) (x in radians)
float pow (float x, float y)	Calculates the exponential value. x is the base, y is the exponent
float fabs(float x)	Calculates the absolute value of x

Example: Accumulated Length

The following example demonstrates how to create a custom measurement that is based on the values from other measurements and persistent values. The example calculates the length of the target using a series of position Z measurement tool values (Measurement ID 1)

```
/* Calculate the length of an object by accumulating the encoder spacing measurements*/
/* Encoder Spacing is 0.5mm */
/* Z position measurement ID is set to 1 */

long long encoder_spacing = 500;
long long height = Measurement_Value(1);
long long length = Memory_Get64s(0);

if (Measurement_Valid(1))
{
    length = length + encoder_spacing;
}
else
{
    length = 0;
}

Memory_Set64s(0, length);

if (length > 10000)
{
    Output_Set(length, 1);
}
else
{
    Output_Set(length, 0);
}
```

Range Measurement Tools

This chapter describes the range measurement tools available in sensors that are equipped with *Measurement Tools*. Measurement *values* are compared against minimum and maximum thresholds to yield *decisions*.

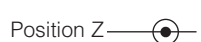
Measurement	Examples
<p>Difference</p> <p>Measures the differences between two features. Difference measurement can be used to calculate thickness or warpage</p> <p>Refer to Difference (page 79).</p>	
<p>Position Z</p> <p>Finds the average z-axis position of a feature.</p> <p>Refer to Position Z (page 80).</p>	

Measurement Types

Difference

A difference measurement determines the difference along the z-axis between two laser ranges. The measurement value can be compared with minimum and maximum constraints to yield a decision.

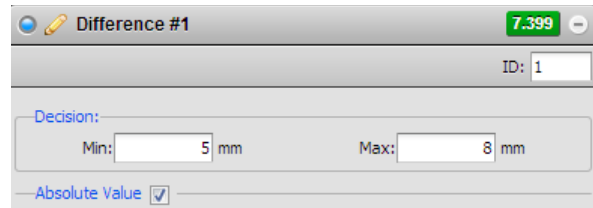
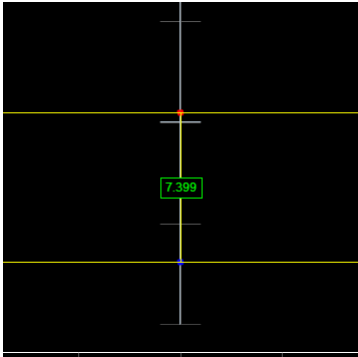

The difference can be expressed as an absolute or signed result. The difference is calculated by

$$\text{Difference} = \text{Range}_{\text{main}} - \text{Range}_{\text{Buddy}}$$

To create or edit a Difference measurement:

- 1 Add a new Height measurement or select an existing Difference measurement.**
- 2 Select the measurement Source.**
Choices that are available depend on the system layout.
- 3 Select absolute or signed result.**
Check the Absolute box to select absolute result.
- 4 Provide minimum and maximum constraints for a decision.**
Refer to Decisions (page 72) for more information on decisions.

Position Z

A Position Z measurement finds the z-axis position of the laser range. The measurement value can be compared with minimum and maximum constraints to yield a decision.

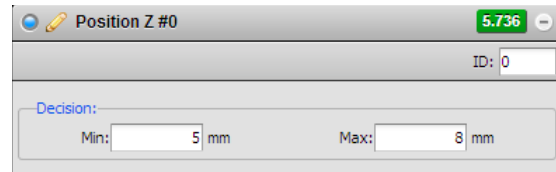
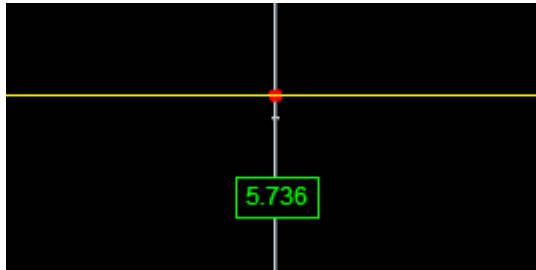

To create or edit a Position Z measurement:

- 1 Add a new Position Z measurement or select an existing Position Z measurement.**
- 2 Select the measurement Source.**
Choices that are available depend on the system layout.
- 3 Provide minimum and maximum constraints for a decision.**
Refer to Decisions (page 72) for more information on decisions.

Script

A Script measurement can be used to program a custom measurement using a simplified C based syntax. A script measurement can produce a measurement value and a measurement decision.

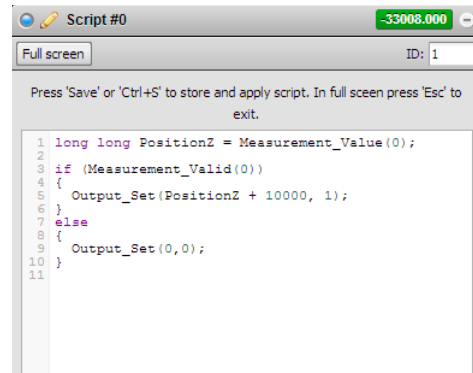
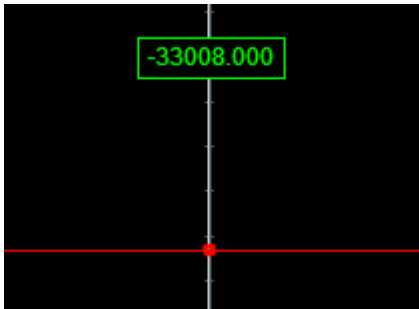
A screenshot of a software window titled "Script #0". The window has a title bar with a green status indicator showing "-33008.000". Below the title bar, there are buttons for "Full screen" and "ID: 1". A message reads: "Press 'Save' or 'Ctrl+S' to store and apply script. In full screen press 'Esc' to exit." The main area contains a code editor with the following C-like code:

```
1 long long PositionZ = Measurement_Value(0);
2
3 if (Measurement_Valid(0))
4 {
5     Output_Set(PositionZ + 10000, 1);
6 }
7 else
8 {
9     Output_Set(0,0);
10 }
11
```

Refer to Script Measurement (page 74) for more information on the script syntax.

To create or edit a Script measurement:

1 Add a new Script measurement or select an existing Script measurement.

2 Edit the script code.

Build up your script by adding one line at a time. The script will be easier to debug if you begin with a few lines and then build it up over a few iterations.

3 Click the Save button to save the script code.

If there is a mistake in the script syntax, the result will be shown as a "invalid" with a red border in the Data Viewer when you run the sensor.

Outputs from multiple measurement tools can be used as inputs to the script. A typical script would take results from other measurement tools using the value and decision function, and output the result using the output function. Video and range data cannot be used as inputs to the script. Only one script can be created.

Output

Output Page

Output configuration tasks are performed using the Output Page. Gocator sensors can transmit laser ranges and measurement results to a variety of external devices using a variety of output interface options.

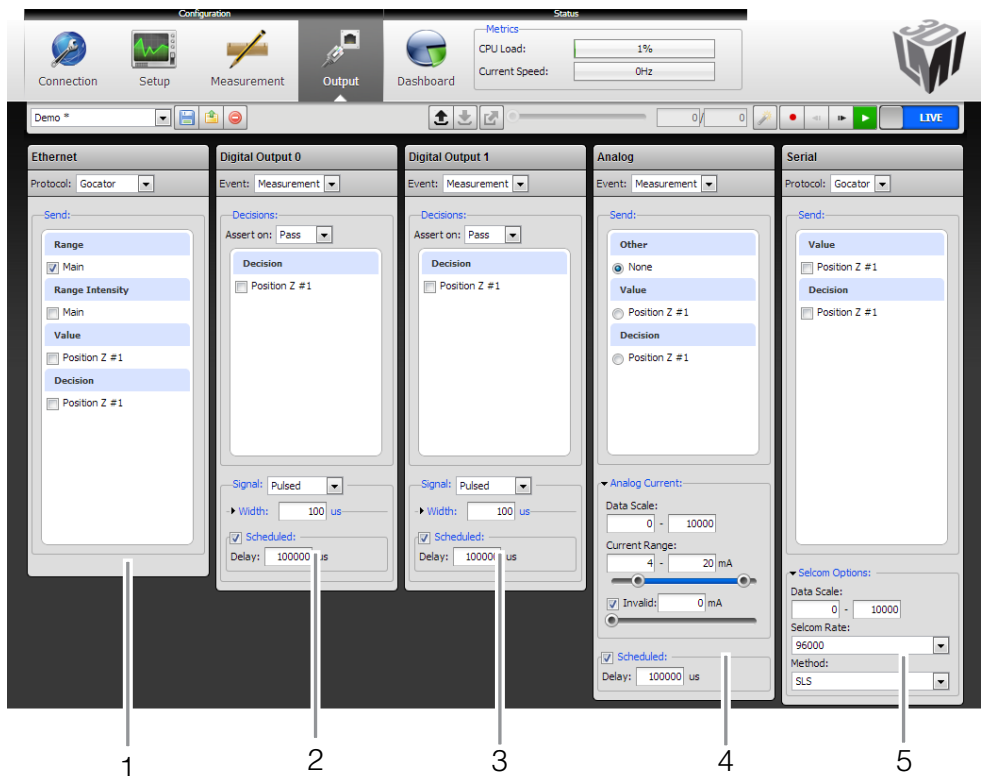

Element	Description
1 Ethernet Panel	Use the Ethernet panel to select the data sources that will be transmitted via Ethernet.
2 Digital Output 0 Panel	Use the Digital Output 0 panel to select the data sources that will be combined to produce a digital output pulse on Output 0.
3 Digital Output 1 Panel	Use the Digital Output 1 panel to select the data sources that will be combined to produce a digital output pulse on Output 1.
4 Analog Panel	Use the Analog panel to convert a measurement value or decision into an analog output signal.
5 Serial Panel	Use the Serial panel to select the measurements that will be transmitted via RS-485 serial output.

Ethernet Control and Output

A sensor uses TCP messages (Gocator Protocol) to exchange commands, video, laser range, intensity and measurement results with client computers. The sensor can also exchange commands and measurement results with a PLC using ASCII, Modbus TCP or EtherNet/IP. Refer to Gocator Protocol (page 124), ASCII Protocol (page 175), Modbus TCP Protocol (page 163) and EtherNet/IP Protocol for the specification of these protocols.

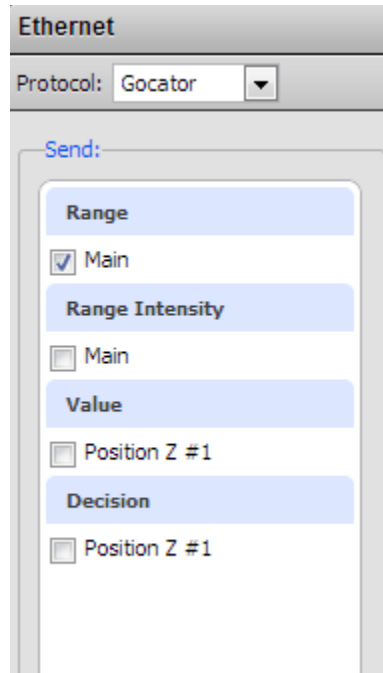

To exchange results using Gocator Protocol messages:

- 1 Navigate to the Ethernet panel.**
- 2 Select Gocator in the Protocol Option.**
- 3 Select the video, ranges, intensity, decision value, or decision items to send.**

To select an item for transmission, place a check in the corresponding check box.

 Measurements shown here correspond to measurements that have been programmed using the Measurements Page.

All of the tasks that can be accomplished via the Gocator's web interface (configuration, calibration, receiving data, health information, and software triggering, etc.) can be accomplished programmatically by sending and receiving Gocator Protocol control commands. The sensor can process the control commands regardless of the selected protocol.

Ethernet

Protocol: ASCII

Send:

Operation: Asynchronous

Data Format: Standard

Value

Strip Height #0

Decision

Strip Height #0

Special Characters:

Delimiter: ,

Termination: %r%n

Invalid Value: INVALID

Ports:

Control: 8190

Data: 8190

Health: 8190

To exchange results using ASCII messages:

1 Navigate to the Ethernet panel.

2 Select ASCII in the Protocol Option.

3 Select the Operation Mode.

In asynchronous mode, the data results are transmitted when they are available. In polling mode, users send commands on the data channel to request the latest result. Refer to Asynchronous and Polling Operation (page 296) for an explanation of the operation modes.

4 Select the Data Format.

Select standard format to use the default result format of the ASCII protocol. Select value and decision to send by placing a check in the corresponding check box. Refer to Standard Result Format (page 176) for an explanation of the standard result mode.

Select custom format to customized the output result. The data format box will appear and users can type in the format string. Refer to Custom Result Format (page 177) for the syntax supported of the format string.

5 Set the Special Characters.

Select the delimiter, termination and invalid value characters. Special characters are used in commands and standard-format data results.

6 Set the TCP Ports

Select the TCP ports for the command, data and health channels. If the port numbers of two channels are the same, the messages for both channels are transmitted on the same port.

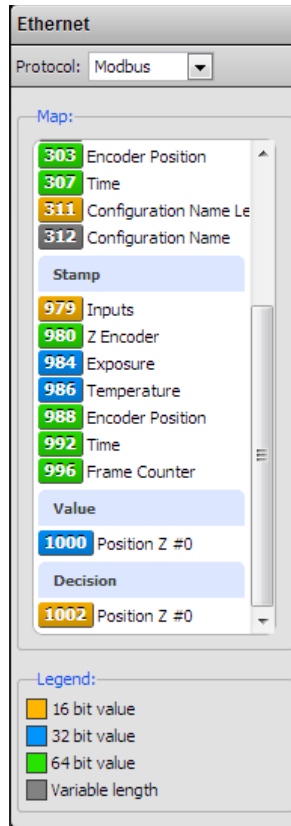

To receive commands and send results using Modbus TCP messages:

1 Navigate to the Ethernet panel.

2 Select Modbus in the Protocol Option.

Unlike using the Gocator Protocol, there is no need to select which measurement items to output. The Ethernet panel will list the register addresses that are used for Modbus TCP communication.

The Modbus TCP Protocol can be used to operate a sensor. Modbus TCP only supports a subset of the tasks that can be accomplished in the web interface. A sensor can only process Modbus TCP commands when the Modbus is selected in the protocol option.

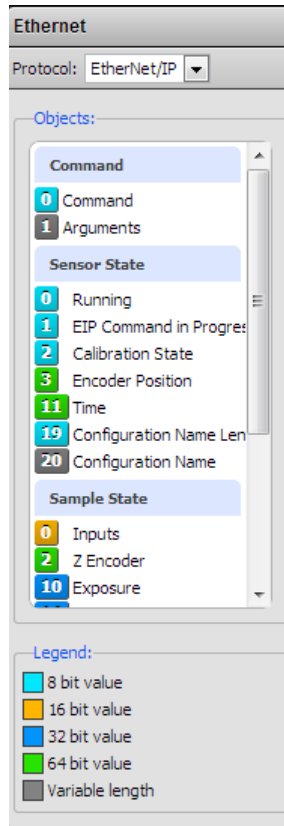

To receive commands and send results using EtherNet/IP messages:

1 Navigate to the Ethernet panel.

2 Select EtherNet/IP in the Protocol Option.

Unlike using the Gocator Protocol, there is no need to select which measurement items to output. The Ethernet panel will list the register addresses that are used for EtherNet/IP messages communication.

The EtherNet/IP Protocol can be used to operate a sensor. EtherNet/IP only supports a subset of the tasks that can be accomplished in the web interface. A sensor can only process EtherNet/IP commands when the EtherNet/IP is selected in the protocol option.

Digital Outputs

Gocator sensors can convert measurement decisions or software commands to digital output pulses, which can then be used to output to a PLC or to control external devices, such as indicator lights or air ejectors.

A digital output can act as a measurement valid signal to allow external devices to synchronize to the timing at which measurement results are output. In this mode, the sensor outputs a digital pulse when a measurement result is ready.

A digital output can also act as a strobe signal to allow external devices to synchronize to the timing at which the sensor exposes. In this mode, the sensor outputs a digital pulse when the sensor exposes.

Each sensor supports two digital output channels. Refer to Gocator 1100/1300 Power/LAN Connector (page 230) for wiring digital outputs to external devices.

Digital Output 0

Event: Measurement ▼

Decisions:

Assert on: Pass ▼

Decision

Position Z #1

Signal: Pulsed ▼

Width: 100 us

Scheduled:

Delay: 100000 us

To output measurement decisions:

- 1 Navigate to the Digital Output 0 or Digital 1 panel.**
- 2 Set Event to Measurement**
- 3 Select Assert Mode and decision sources that should be combined to determine the output.**

If multiple decision sources are selected and assert mode is set to pass, the output is activated when all selected measurement decisions pass. Conversely, if assert mode is set to false, the output is activated when any one of the selected measurement decisions is false.

4 Specify a Signal type.

The signal type specifies whether the digital output is a continuous signal or a pulsed signal. If the signal is continuous its state is maintained until the next transition occurs. If the signal is pulsed, the user specifies the pulse width and how it is scheduled.

5 Specify a Pulse Width.

The pulse width is the duration of the digital output pulse, in microseconds.

6 Specify the output is Immediate or Scheduled.

A pulsed digital output can be immediate or scheduled. Check the Scheduled option if the output needs to be scheduled.

A scheduled output becomes active after a specified delay from the start of Gocator exposure. A scheduled output can be used to track the decisions for multiple objects as these objects travel from the sensor to the eject gates. The delay specifies the distance from the sensor to the eject gates.

An Immediate output becomes active as soon as measurement results are available. The output activates after the sensor finishes processing the data. As a result, the time between the start of sensor exposure and output activates can vary and is dependent on the processing latency. The latency is reported in the dashboard and in the health messages.

7 Specify a Delay.

The delay specifies the time or spatial location between the start of sensor exposure and when the output becomes active. The delay should be larger than the time needed to process the data inside the sensor. It should be set to a value that is larger than the processing latency reported in the dashboard or in the health messages.

The unit of the delay is configured in the trigger panel. Refer to Trigger (page 51) for details.

To output a measurement valid signal:

1 Navigate to the Digital Output 0 or Digital 1 panel.

2 Set Event to Measurement.

3 Set Assert On to Always.

4 Select decision sources.

The output activates when the selected decisions produce results. The output activate only once for each frame even if multiple decision sources are selected.

5 Specify a Pulse Width.

The pulse width determines the duration of the digital output pulse, in microseconds.

To respond to software scheduled commands:

1 Navigate to the Digital Output 0 or Digital 1 panel.

2 Set Event to Software.

3 Specify a Signal type.

The signal type specifies whether the digital output is a continuous signal or a pulsed signal. If the signal is continuous, its state is maintained until the next transition occurs. If the signal is pulsed, user specifies the pulse width and the delay.

4 Specify a Pulse Width.

The pulse width determines the duration of the digital output pulse, in microseconds.

5 Specify if the output is Immediate or Scheduled.

A pulsed signal can become active immediately or scheduled. Continuous signal always becomes active immediately.

Immediate output becomes active as soon as a Scheduled Digital Output command (page 142) is received.

Scheduled output becomes active at a specific target time or position, given by the Scheduled Output command. The Delay setting in the panel is ignored. Commands that schedule event in the past will be ignored. An encoder value is in future if the value will be reached by moving in the forward direction (the direction that travel calibration was performed in).

To output an exposure signal:

1 Navigate to the Digital Output 0 or Digital 1 panel.

2 Set Event to Exposure.

3 Specify a Pulse Width.

The pulse width determines the duration of the digital output pulse, in microseconds.

Analog Output

Gocator sensors can convert a measurement result or software request to an analog output. Each sensor supports one analog output channel.

Refer to Analog Output (page 237) for information on wiring analog output to an external devices.

The screenshot shows the 'Analog' configuration window. At the top, the 'Event' is set to 'Measurement'. Below this, the 'Send:' section has three main categories: 'Other', 'Value', and 'Decision'. Under 'Other', the 'None' radio button is selected. Under 'Value', no radio button is selected. Under 'Decision', the 'Position Z #1' radio button is selected. The 'Analog Current:' section is expanded and contains: 'Data Scale' with input fields for '0' and '10000'; 'Current Range' with input fields for '4' and '20 mA' and a slider below; 'Invalid' with a checked checkbox and an input field for '0 mA' and a slider below; and 'Scheduled' with a checked checkbox and a 'Delay' input field set to '100000 us'.

To output measurement value or decision:

1 Navigate to the Analog panel.

2 Set Event to Measurement.

3 Select the value or decision source that should be used for output.

Only one value or decision can be used for analog output. Measurements shown here correspond to measurements that have been programmed using the Measurements Page.

4 Specify Data Scale values.

The values specified here determine how measurement values are scaled to the minimum and maximum current output. The Data Scale is specified in (μm) for dimensional measurement, (0.001 mm^2) for area, (mm^3) for volume and (0.001 degree) for angle results.

5 Specify Current Range and Invalid current values.

The values specified here determine the minimum and maximum current values in milliamperes. The invalid current value is used when a measurement value is not valid. If invalid is not checked, the output holds the last value when a measurement value is not valid.

6 Specify if the output is Immediate or Scheduled.

An analog output can become active immediately or scheduled. Check the Scheduled option if the output needs to be scheduled.

A scheduled output becomes active after a specified delay from the start of Gocator exposure. A scheduled output can be used to track the decisions for multiple objects as these objects travel from the sensor to the eject gates. The delay specifies the distance from the sensor to the eject gates

An Immediate output becomes active as soon as the measurement results are available. The output activates after the Gocator finishes processing the data. As a result, the time between the start of Gocator exposure and output activates depends on the processing latency. The latency is reported in the dashboard and in the health messages.

7 Specify a Delay.

The delay specifies the time or spatial location between the start of Gocator exposure and the output becomes active. The delay should be larger than the time needed to process the data inside the Gocator. It should be set to a value that is larger than the processing latency reported in the dashboard and in the health messages.

The unit of the delay is configured in the trigger panel. Refer to Trigger (page 51) for details.

 The analog output takes about 75 us to reach 90% of the target value for a maximum change, then another ~40 us to settle completely.

To respond to software scheduled commands:

1 Navigate to the Analog panel.

2 Set Event to Software.

3 Specify if the output is Immediate or Scheduled.

An analog output value becomes active immediately or scheduled. Immediate output becomes active as soon as a Scheduled Analog Output (page 143) is received.

Software scheduled command can schedule an analog value to output at a specified future time or encoder value, or changes its state immediately. The Delay setting in the panel is ignored. Commands that schedule event in the past will be ignored. An encoder value is in future if the value will be reached by moving in the forward direction (the direction that travel calibration was performed in).

Serial Output

The Gocator's web interface can be used to select measurement values and decisions to be transmitted via RS-485 serial output. Each sensor has one serial output channel.

Two protocols are supported: ASCII Protocol and Selcom Serial Protocol. The ASCII protocol outputs data asynchronously using a single serial port. The Selcom Serial Protocol outputs synchronized serial data using two serial ports. Refer to ASCII Protocol (page 175) for the ASCII Protocol parameters and data formats. Refer to for the Selcom serial protocol and data formats.

Refer to Serial Output (page 235) for information on wiring serial output to an external device.



The screenshot shows a web interface titled "Serial". At the top, there is a "Protocol:" dropdown menu set to "ASCII". Below this is a "Send:" section with a "Data Format:" dropdown menu set to "Standard". Under "Data Format:", there are two sections: "Value" and "Decision". Each section has a checkbox labeled "Strip Height #0". The "Value" checkbox is checked, and the "Decision" checkbox is also checked. Below these sections is a "Special Characters:" section with three input fields: "Delimiter:" (containing a comma), "Termination:" (containing "%r%n"), and "Invalid Value:" (containing "INVALID").

To exchange results using ASCII messages:

1 Navigate to the Ethernet panel.

2 Select ASCII in the Protocol Option.

3 Select the Data Format.

Select standard format to use the default result format of the ASCII protocol. Select value and decision to send by placing a check in the corresponding check box. Refer to Standard Result Format (page 176) for an explanation of the standard result mode.

Select custom format to customized the output result. The data format box will appear and users can type in the format string. Refer to Custom Result Format (page 177) for the syntax supported of the format string.

4 Set the Special Characters.

Select the delimiter, termination and invalid value characters. Special characters are used in commands and standard-format data results.



To configure Selcom serial output:

1 Navigate to the Serial panel.

2 Select Selcom in the Protocol Option.

3 Select the measurement value and decision items to send.

To select an item for transmission, place a check in the corresponding check box. Measurements shown here correspond to measurements that have been programmed using the Measurements Page.

4 Select the Output speed.

5 Specify Data Scale values.

The values specified here determine how measurement values are scaled to the minimum and maximum current output. The Data Scale is specified in (um) for dimensional measurement, (0.001 mm²) for area, (mm³) for volume and (0.001 degree) for angle results.

The results are scaled according to the number of serial bits used to cover the data scale range. For example, the 12-bit output would break a 200 mm data scale range into 4096 increments (0.0488 mm/bit), and the 14-bit output would break a 200 mm data scale range into 16384 increments (0.0122 mm/bit).

6 Specify the Data Format.

Refer to Selcom Serial Protocol (page 184) for definition of the formats.

Toolbar

The tool bar is the central place for performing common operations. This chapter explains how to use the toolbar to manage the sensor configurations and to operate the sensor.

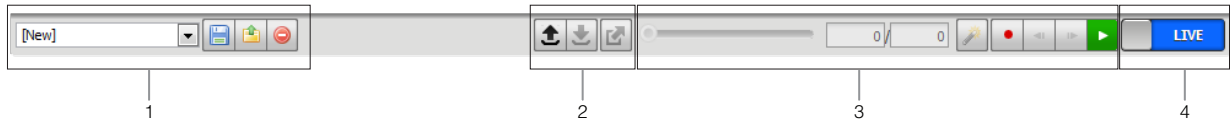

Element	Description
1	Configuration Controls Use the configuration controls to manage sensor settings.
2	Recorded Data Controls Use the recorded data controls to download, export and upload recorded data.
3	Sensor Operation / Replay Control Use the sensor operation controls to start sensors, enable recording and control recorded data.
4	Data Source Use the Data Source button to switch the sensor between live and replay mode.

Saving and Loading Settings

When you change sensor settings using the Gocator web interface, some changes are saved automatically, while other changes are temporary until you take action to save them. The following table summarizes the types of information that can be saved in a sensor.

Saved Information

Information Type	Behavior
Network Address	Network address changes are saved when you click the Save button in Main panel on the Connection Page. The sensor must be reset before changes take effect.
Configuration	Most of the settings that can be changed in the Gocator's web interface, such as those shown on Setup, Measurement, and Output pages, are temporary until saved in a <i>configuration</i> file. Each sensor can have multiple configuration files. If there is a configuration file that is designated as the <i>default</i> , it will be loaded automatically when the sensor is reset.
Calibration	<i>Calibration</i> files, described in Calibration (page 63), are saved automatically at the end of the calibration procedure. If a sensor contains a calibration file, it will automatically be loaded when the sensor is reset.

Each sensor can have, at most, one calibration record. But sensors can contain many configurations – the number of files is limited only by the sensor's flash storage capacity.

Because configuration is often used together to perform a particular task, the Gocator's web interface provides tool bar commands to load and save these files as a pair.

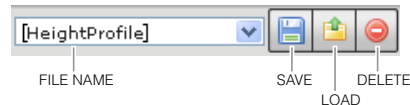

The File name drop down list shows the list of configuration stored in the sensor. The configuration that is currently loaded will be listed at the top. The name will be marked with an asterisk if the live configuration is different from the loaded configuration to indicate unsaved changes.

To save a new configuration file:

- 1 Select [New] in the File Name drop list.**
- 2 Enter a name for the file pair.**
- 3 Press the Enter key or click the Save button.**

The configuration will be saved to flash memory using the name provided. The saved files will be set as the defaults to be loaded automatically when the sensor is reset.

To overwrite an existing configuration file:

1 Select an existing file name in the File Name drop list.

2 Click the Save button.

A dialog will be prompted to confirm overwriting the existing files. The configuration will be saved to flash memory using the selected name. The saved files will be set as the defaults to be loaded automatically when the sensor is reset.

To load a configuration file:

1 Select an existing file name in the File Name drop list.

2 Click the Load button.

The configuration and the template are loaded from flash memory. Any unsaved changes to current settings will be overwritten when the files are loaded.

To delete a configuration file:

1 Select an existing file name in the File Name drop list.

2 Click the Delete button.

The configuration and the template are deleted from the flash memory.

Managing individual files are described in the File Management (page 110) section.

Managing Multiple Settings

A Gocator can store multiple sets of configurations and templates. This can be used when one set of equipment is used for different purposes or with different constraints during separate production runs. For example, width decision constraints might be loose during one production run and tight during another depending on the desired grade of the part.

To manage a system with multiple configurations:

1 Configure settings for the first target object.

Use the Setup, Measurement, and Output Pages to configure settings for the first target.

2 Save the first configuration.

Enter a file name and use the Save button to save the configuration.

3 Configure settings for the second target object.

Use the Setup, Measurement, and Output Pages to configure settings for the second target.

4 Save the second configuration.

Enter a file name (different from the one used for the first configuration) and use the Save button to save the configuration

5 When production changes, load the desired configuration.

Select the desired configuration and click the Load button. The configuration will be loaded and the sensors will ready for production.

Recording and Playback

Gocator sensors have the ability to record and replay data. This feature is most often used for troubleshooting measurements, but can also be helpful during setup.

Recording and playback are controlled by using commands in the tool bar.

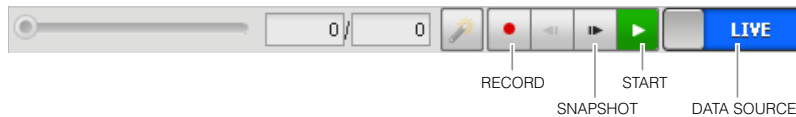

Recording and Playback commands when Data Source is Live



Recording and Playback commands when Data Source is Replay

To record live data:

1 Toggle the Data Source to Live.

2 Press the Record button.

When the Data Source is set to Live and recording is enabled, the sensor will store the most recent data as it runs. Remember to disable recording if you no longer wish to record live data (press the Record button again to disable).

3 Press the Snapshot button or Start button.

Snapshot will cause a single frame to be recorded. The Start button will run the sensor continuously and all frames will be recorded, up to available memory. When the memory limit is reached, the oldest data will be discarded. New data is appended to the record buffer unless the configuration has changed.

 New record data is appended to existing replay data unless the sensor configuration has been modified.

To replay recorded data:

1 Toggle the Data Source to Replay.

2 Use the Replay Slider, Step Forward, Step Back, or Play buttons to review data.

The Step buttons advance / reverse the current replay location by a single frame. The Play button advances the replay location continuously, animating the playback. The Pause button (replaces the Play button while playing) can be used to pause the replay at a particular location. The Replay slider (or Replay Position box) can be used to navigate to a specific replay frame.

To clear recorded data:

1 Toggle the Data Source to Replay.

2 Press the Clear Replay button.

Downloading, Exporting and Uploading Recorded Data

Recorded data can be downloaded or exported to the client computer or uploaded to the Gocator. Export is often used for processing the recorded data using 3rd party tools. Recorded data can also be downloaded in a binary format. It is used to backup the data for reviewing in the future.

 Recorded data is not saved or loaded along with other files when you use the Save or Load commands in the Gocator's tool bar.

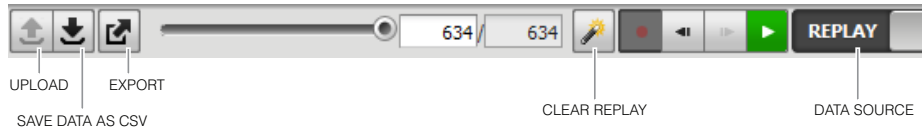

To download recorded data:

- 1 Toggle the Data Source to Replay.**
- 2 Press the Download button.**
- 3 Select the directory and file name to store on the client computer. Press OK.**

To upload recorded data:

- 1 Toggle the Data Source to Live.**
- 2 Press the Upload button.**
- 3 Select the directory and the file name to load from the client computer. Press OK.**

Recorded range and measurement data can be exported to CSV format. Recorded data can be exported by using the export command in the Gocator tool bar in replay mode.

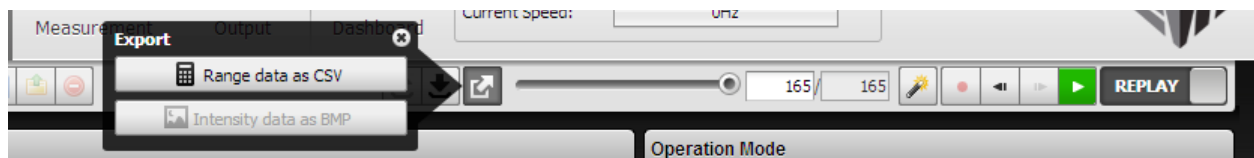

To export recorded data to CSV:

- 1 Toggle the Data Source to Replay.**
- 2 Press the Export button.**
Select Export Ranges as CSV. All data, including the intensity values, in the record buffer is exported.
- 3 Select the directory and file name to store on the client computer. Press OK.**

Dashboard

Dashboard Page

The Dashboard Page summarizes logged events, sensor health information, and measurement statistics.

The screenshot shows a dashboard interface with the following components:

- 3**: Metrics panel showing CPU Load (58%) and Current Speed (10039Hz).
- 4**: Event Log table with columns for Time and Log.
- 1**: Health section with a 'Live' tab and various system metrics.
- 2**: Statistics table with columns for Measurements, Value, Min, Max, Avg, Std Dev, Pass, Fail, and Invalid.

Measurements	Value	Min	Max	Avg	Std Dev	Pass	Fail	Invalid
Position Z #0	0	0	0	0	0	24904	0	0

System State	Running
Speed	10039 Hz
Firmware Version	3.4.1.111
Interface Version	3.4.1.111
Up Time	00:0H:0M:49S
Encoder Value	0 ticks
Encoder Frequency	0 Hz
CPU Usage	58 %
Memory Usage	88.36 MB
Memory Capacity	192.00 MB
Storage Usage	5.35 MB
Storage Capacity	39.88 MB
Temperature	34 C
Ethernet Traffic	1064 Bytes/s
Output Latency	238 us
Max Output Latency	1304 us

Element	Description	
1	State and Health Information	Displays sensor state and health information.
2	Measurement Statistics	Displays measurement statistics.
3	Metric Panel	Summarizes important performance statistics.
4	Event Log	Displays log data from the sensor.

State and Health Information

The following state and health information is available on the Dashboard:

Dashboard Health Values

Name	Description
System State	Current system state (Ready or Running).
Speed	Current laser/camera speed (Hz).
Firmware Version	Gocator firmware version.
Interface Version	Gocator interface version.
Up Time	Length of time since the sensor was power-cycled or reset.
Encoder Value	Current encoder value (ticks).
Encoder Frequency	Current encoder frequency (Hz).
Trigger Drops	Count of camera frames dropped due to excessive trigger speed.
CPU Usage	Sensor CPU utilization (%).
Memory Usage	Sensor memory utilization (MB).
Memory Capacity	Sensor memory capacity (MB).
Storage Usage	Sensor flash storage utilization (MB).
Storage Capacity	Sensor flash storage capacity (MB).
Temperature	Sensor internal temperature (C).
Laser Temperature	Laser temperature (C). Available only on sensors equipped with 3B-N lasers.
Ethernet Traffic	Network output utilization (Bytes/sec).
Camera Drops	Count of frame drops due to camera errors.
Processing Drops	Count of frame drops due to excessive CPU utilization.
Ethernet Drops	Count of frame drops due to slow Ethernet link.
Digital Output Drops	Count of digital output drops because last output has not been completed.
Analog Output Drops	Count of analog output drops because last output has not been completed.
Serial Output Drops	Count of serial output drops because last output has not been completed.
Processing Latency	Last delay from camera exposure to when results can be scheduled to.
Max Processing Latency	Latency Maximum delay from camera exposure to when results can be scheduled to Rich I/O. Reset on start.
Camera Frame Count	Count of camera frame captured since the sensor was started.

Measurement Statistics

Statistics are displayed for each measurement that has been configured on the Measurement Page. The following information is available for each measurement:

Dashboard Measurement Statistics

Name	Description
Value	The most recent measurement value.
Minimum/Maximum Value	The minimum and maximum measurement values that have been observed.
Average	The average of all measurement results collected since the sensor was started.
Standard Deviation	The standard deviation of all measurement results collected since the sensor was started.
Pass/Fail Count	The count of pass or fail decisions that have been generated.
Invalid Count	The count of frames that no feature points could be extracted from the live data.

Metric Panel

Metric panel displays two important performance statistics in real-time: CPU Load and Current Frame Rate (Speed).

The CPU Load bar in the Metric panel (at the top of the interface) displays how much of the CPU is being utilized. A warning will appear if the sensor drops ranges because CPU is over utilized.

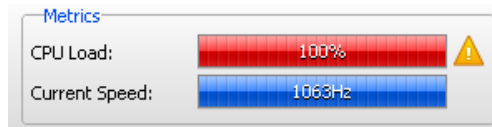

The Speed bar displays the frame rate of the sensor. A warning will appear if triggers (external input or encoder) are dropped because the external rate exceeds the maximum frame rate.

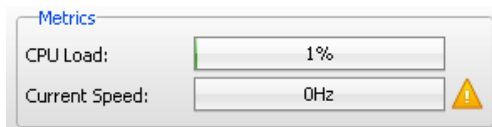

When a warning appears, click on the warning sign to reveal notifications that display more detailed information.

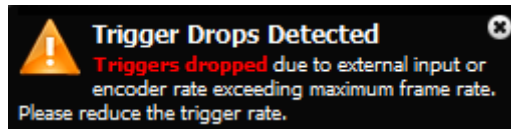

Connection and Maintenance

Connection Page

Gocator's security, file management and maintenance tasks are performed on the Connection Page.

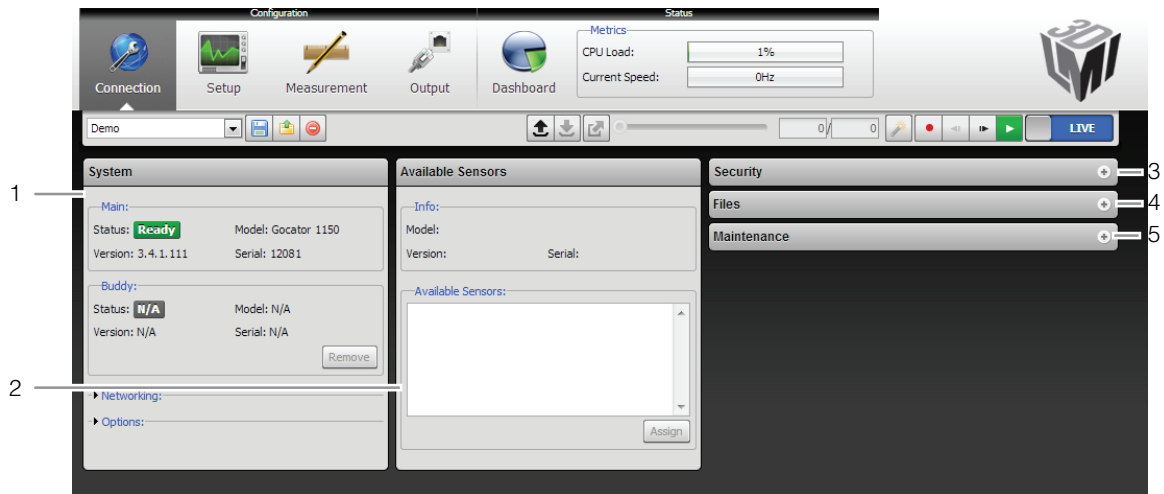

Element	Description
1	System Panel Use the System panel to configure sensor network and boot-up settings.
2	Available Sensor Panel Use the Available Sensor panel to assign or unassign Buddy sensors.
3	Security Panel Use the Security panel to change passwords.
4	Files Panel Use the Files panel to manage files stored on the main sensor.
5	Maintenance Panel Use the Maintenance panel to upgrade firmware, create/restore backups or reset sensors.

Network Settings

The network settings need to be configured to match the network to which the Gocator sensors are connected.

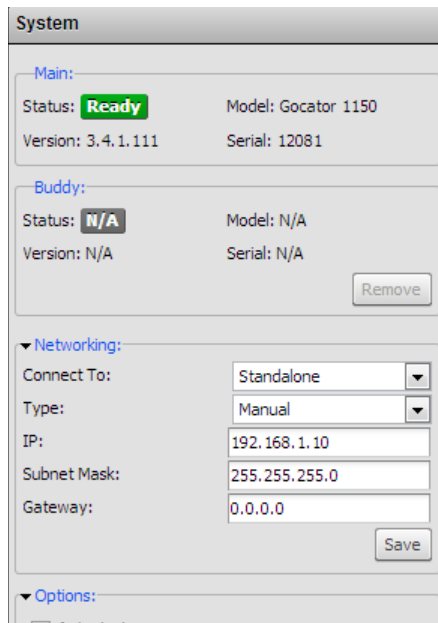

The screenshot shows a 'System' configuration window. It is divided into three main sections: 'Main', 'Buddy', and 'Networking'.
- The 'Main' section shows 'Status: Ready' (in a green box), 'Model: Gocator 1150', 'Version: 3.4.1.111', and 'Serial: 12081'.
- The 'Buddy' section shows 'Status: N/A' (in a grey box), 'Model: N/A', 'Version: N/A', and 'Serial: N/A'. There is a 'Remove' button at the bottom right of this section.
- The 'Networking' section is expanded and contains:
 - 'Connect To': A dropdown menu set to 'Standalone'.
 - 'Type': A dropdown menu set to 'Manual'.
 - 'IP': A text input field containing '192.168.1.10'.
 - 'Subnet Mask': A text input field containing '255.255.255.0'.
 - 'Gateway': A text input field containing '0.0.0.0'.
 - A 'Save' button is located at the bottom right of the Networking section.
- Below the Networking section, the 'Options' section is partially visible.

To configure the network settings:

1 Navigate to the System panel.

Click the arrow next to Networking to expand the panel.

2 Specify the Connect To setting.

The Connect To setting specifies whether the sensor system is standalone or connected to a Master.

3 Specify the Type, IP, Subnet Mask and Gateway settings.

The Gocator sensor can be configured to use DHCP, or assigned a static IP address.

4 Click Save.

When you click the Save button, you will be prompted to confirm your selection.

5 Reset or power-cycle the sensor.

After changing network settings, the sensor must be reset or power-cycled before the change will take effect.

The Reset Sensor button in the Maintenance (page 111) the can be used to perform a software reset.

Auto Starting Sensors

With the Autostart setting enabled, laser ranging and measurement functions will begin automatically when the sensor is powered on. This setting is necessary when the sensor will be used without a computer connected.

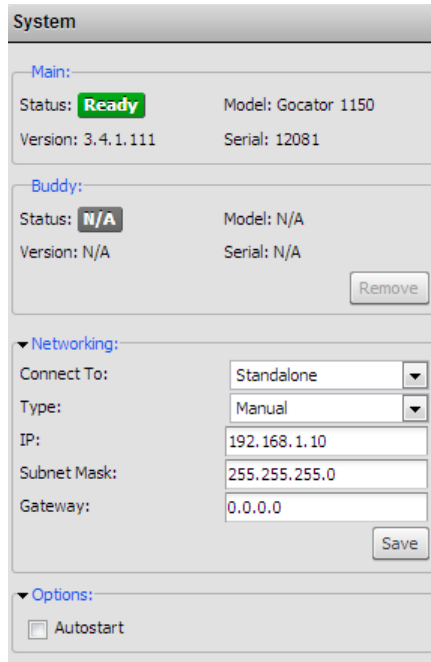

To enable/disable Autostart:

- 1 Check/Uncheck Autostart option box.
- 2 Save configuration.

Overheat Protection

Sensors with 3B-N laser by default will turn off the laser if the temperature exceeds the safe operating range. Users can override this behavior by disabling the overheat protection.

 Disabling the setting is not recommended. Disabling the overheat protection feature could lead to immature laser failure if the sensor operates outside the specified temperature range.

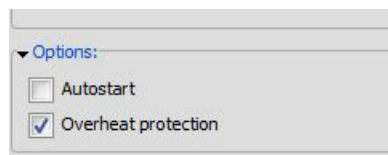

To enable/disable Overheat Temperature Protection:

- 1 **Check/Uncheck Overheat Protection option box.**
- 2 **Save configuration.**

Buddy Assignment

In a dual sensor system, the Main sensor assumes control of the Buddy sensor after the Buddy sensor is assigned to the Main sensor. Configuration for both sensors can be performed through the Main sensor's interface.

- Main and Buddy sensors must be assigned unique IP addresses before they can be used on the same network. Before proceeding, connect the Main and Buddy sensors one at a time (to avoid an address conflict) and use the steps outline in Running a Dual Sensor System (page 37) to assign each sensor a unique address.

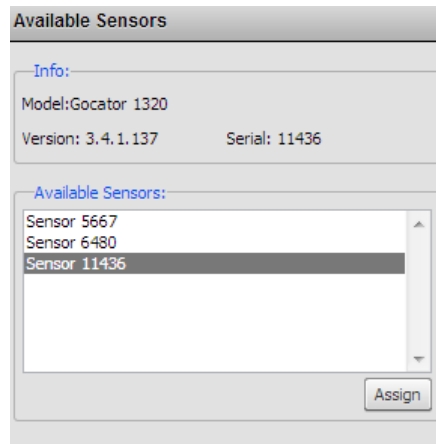

To assign a Buddy sensor:

1 Navigate to the Available Sensors panel.

2 Select a Buddy sensor.

The firmware on Main and Buddy sensors must be the same for Buddy assignment to be successful. If the firmware is different, connect the Main and Buddy sensor one at a time.

3 Click Assign.

The Buddy sensor will be assigned to the Main sensor and its status will be updated in the System panel.

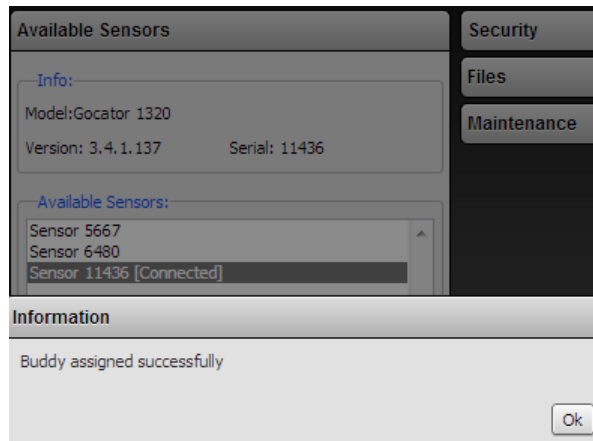

Security

Gocator sensors can be secured with passwords to prevent unauthorized access. Each sensor has two accounts: Administrator and Technician.

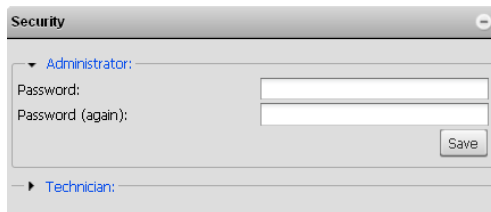

Gocator Account Types

Account	Description
Administrator	The Administrator account has privileges to view and edit all settings, and to perform setup procedures such as sensor calibration.
Technician	The Technician account has privileges to view the Dashboard Page and to Start or Stop the sensor.

The Administrator and Technician accounts can be assigned unique passwords. By default, passwords are blank (empty).

To set or change the password for the Administrator account:

1 Navigate to the Security panel.

Click the arrow next to Administrator to expand the panel.

2 Enter the new Administrator account password and password confirmation.

3 Click Save.

The new password will be required the next time that an administrator logs in to the sensor.

To set or change the password for the Technician account:

1 Navigate to the Security panel.

Click the arrow next to Technician to expand the panel.

2 Enter the new Technician account password and password confirmation.

3 Click Save.

The new password will be required the next time that a technician logs in to the sensor.

If the administrator or technician password is misplaced, the sensor can be recovered using a special software tool. Refer to Recovery (page 113) for more information.

File Management

The Files panel can be used to manage configurations and templates.

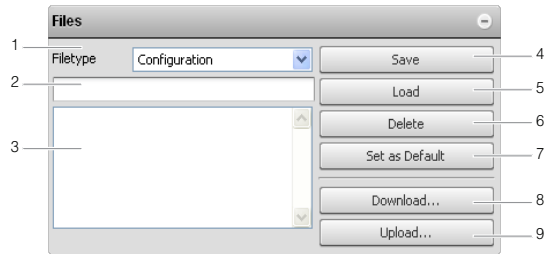

Element	Description	
1	File Type	Specifies the type of files to manage (Configuration).
2	File Name Field	Used to provide a file name when saving files.
3	File List	Displays the files that are currently saved in the sensor's flash storage.
4	Save Button	Saves currently loaded data to file using the name in the File Name Field.
5	Load Button	Loads the file that is selected in the File List.
6	Delete Button	Deletes the file that is selected in the File List.
7	Set as Default Button	Sets the selected file as the default to be loaded at boot time.
8	Download Button	Downloads the selected file to the client computer.
9	Upload Button	Uploads a file from the client computer.

The following types of files can be saved and loaded:

File types

File Type	Description
Configuration	Contains the settings specified in the Setup, Measurement, and Output Pages.

To manage a configuration or template file:

1 Navigate to Files panel.

2 Select the File Type.

3 Select the file in the File list.

To save the live configuration or template to a file, type in a new file name or select a file to replace with.

4 Select the action.

Maintenance

The Maintenance panel can be used to create sensor backups, restore from a backup, or restore to factory defaults.

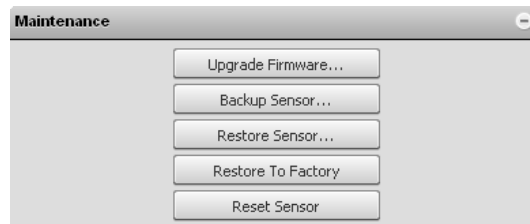

Backup files contain all of the information stored on board a sensor, including configuration and calibration.

 It is recommended that Administrators create a backup file in the unlikely event that a sensor fails and a replacement sensor is needed. In such an event, the new sensor can be restored with the backup file.

To create a backup:

- 1 Navigate to the Maintenance panel.**
- 2 Click the Backup Sensor... button.**
- 3 When prompted, specify a location to save the backup.**
The backup will be saved to the specified location on the client computer. Backups are saved as a single archive that contains all of the files from the sensor.

To restore from a backup:

- 1 Navigate to the Maintenance panel.**
- 2 Click the Restore Sensor... button.**
- 3 When prompted, select a backup file to restore.**
The backup file will be uploaded and then used to restore the sensor. Any files that were on the sensor before the restore operation will be lost.

To restore a sensor to its factory default settings:

- 1 Navigate to the Maintenance panel.**
- 2 Consider making a backup.**
Restoring factory defaults cannot be undone. It is recommended to make a backup before proceeding.
- 3 Click the Restore to Factory button.**
- 4 Reset the sensor.**
After restoring factory defaults, it is necessary to reset the sensor before the changes will take effect. Use the Reset Sensor button or cycle the power to affect a reset.

Firmware Upgrade

LMI recommends routinely updating firmware to ensure that Gocator sensors always have the latest features and fixes.

 In order for the Main and Buddy sensors to work together, they must be use the same firmware version. This can be achieved by performing an upgrade through the Main sensor, or upgrading each sensor individually.

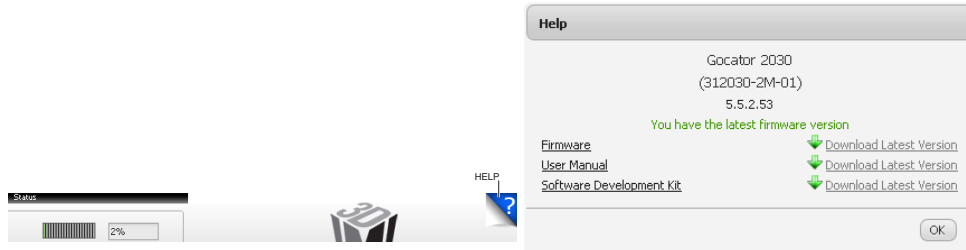

To download the latest firmware:

1 Click on the Help Link.

Ensure that the client computer is connected to the Internet.

2 Determine if an update is required.

The Help panel will check the LMI website to determine if the sensor's firmware is up to date.

3 Download the latest firmware.

If sensor firmware is not up to date, click the Firmware Link to visit the LMI website and then download the latest firmware.

If the client computer is not connected to the Internet, firmware can be downloaded and transferred to the client computer by using another computer to download the firmware from the LMI Technologies website: <http://www.lmi3d.com/support/downloads>

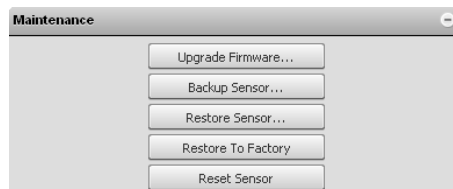

To upgrade the firmware

1 Navigate to the Maintenance panel.

2 Click the Update Firmware button.

3 Provide the location of the firmware file in the File dialog.

4 Wait for the upgrade to complete.

After the firmware upgrade is complete, the sensor will self-reset. If a buddy has been assigned, it will be automatically upgraded and reset along with the Main sensor.

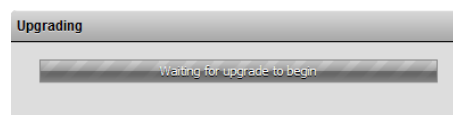

Recovery

Sensor Recovery Tool

If a sensor's network address or administrator password is forgotten, the sensor can be discovered on the network and/or restored to factory defaults by using a special software tool called the Sensor Discovery tool. This software tool can be obtained from the downloads area of LMI's website at <http://www.lmi3d.com>.

After downloading the tool package [14405-x.x.x.x_software_go2_tools.zip], unzip the file and run the Sensor Discovery Tool [bin>win32>kDiscovery.exe].

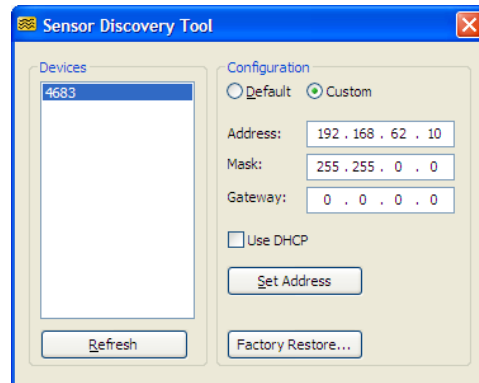

Any sensors that are discovered on the network will be displayed in the Devices list.

To change the network address of a sensor:

- 1 Select the sensor serial number in the Devices list.**
- 2 Select the Custom option.**
- 3 Enter the new network address information.**
- 4 Press the Set Address button.**

To restore a sensor to factory defaults:

- 1 Select the sensor serial number in the Devices list.**
- 2 Press the Factory Restore... button.**

Confirm when prompted.

 The Sensor Discovery tool uses UDP broadcast messages to reach sensors on different subnets. This enables the Sensor Discovery tool to locate and re-configure sensors even when the sensor IP address or subnet configuration is unknown.

Gocator Configuration File

Configuration files contain settings that govern system behavior in the Running state.

Configuration are saved in XML format. Elements contain three types of values: *settings*, *constraints*, and *properties*. Settings are input values that can be edited. Constraints are read-only limits that define the valid values for settings. Properties are read-only values that provide supplemental information related to sensor setup.

When a configuration file is received from a sensor, it will contain settings, constraints, and properties. When a configuration file is sent to a sensor, any constraints or properties in the file will be ignored.

Changing the value of a setting can potentially affect multiple constraints and properties. After uploading a configuration file, the configuration file can be downloaded again to access updated values.

All Gocator sensors share a common configuration XML structure. This section only describes the elements that are applicable to the Gocator 1100 & 1300 series.

When editing the configuration file manually, users should only edit the elements that are applicable and leave the other elements in the structure.

Setup

The Setup element contains settings related to system and sensor setup.

Setup Child Elements

Element	Type	Description
StartupState	32s	Setting for the default state of the system at boot time: 0 – Ready. 1 – Running.
StartupModeOptions	String	Constraint for startup modes – comma delimited list.
StartupMode	String	Setting for the default system mode at boot time.
IntensityEnable	32u	Setting to disable or enable intensity output: 0 – Disable 1 – Enable

TRIGGER

The Trigger element contains settings related trigger source, speed, and encoder resolution.

Trigger Child Elements

Element	Type	Description
TriggerSource	32s	Setting for trigger source: 0 – Time 1 – Encoder 2 – Input 3 – Software

Element	Type	Description
SystemDomain	32s	Setting for units for trigger delay and output scheduling (Ignored when TriggerSource is Time or Encoder): 0 – Microseconds 1 – Millimeters
FrameRate	64f	Setting for frame rate (Hz) (Applicable for time-based triggering).
FullFrameRateEnable	32u	Setting to enable or disable full frame rate operation: 0 – Use FrameRate setting 1 – Ignore FrameRate setting, run at maximum frame rate
EncoderTriggerMode	32s	Setting for the encoder behavior: 0 – Track Reverse 1 – Ignore Reverse 2 – Bi-directional
EncoderPeriod	64f	Setting for encoder period (mm). (Applicable for encoder-based triggering)
TriggerDelay	64f	Setting for trigger delay (us or mm).
GateEnable	32u	Setting to disable or enable the use of digital input to gate the time or encoder trigger source: 0 – Disable 1 – Enable
BatchCount	32u	Number of frames to batch into one bundle.
FrameRateMin	64f	Constraint for minimum frame rate (Hz).
FrameRateMax	64f	Constraint for maximum frame rate (Hz).
FrameRateMaxSource	32s	Source of maximum frame rate constraint: 0 – Imager
EncoderPeriodMin	64f	Constraint for minimum encoder period (ticks).
EncoderPeriodMax	64f	Constraint for maximum encoder period (ticks).
EncoderPeriodMinSource	32s	Source of minimum encoder period constraint: 0 – Encoder resolution
TriggerDelayMin	64f	Constraint for minimum trigger delay (us or ticks).
TriggerDelayMax	64f	Constraint for maximum trigger delay (us or ticks).

LAYOUT

The Layout element contains settings related to the layout/orientation of the system.

Layout Child Elements

Element	Type	Description
Orientation	32s	Setting for orientation type: 0 – Isolated 1 – Wide 3 – Opposite
CalibratedZ	64f	Property for system-calibrated active area Z position (mm).
CalibratedHeight	64f	Property for system-calibrated active area height (mm).

CALIBRATION

The Calibration element contains settings related to alignment and travel calibration.

Calibration Child Elements

Element	Type	Description
AlignmentTarget	32s	Setting for alignment calibration target type: 0 – None 2 – Bar
TravelTarget	32s	Setting for travel calibration target type: 2 – Bar
Bar/Height	64f	Setting for height of calibration bar (mm).
Bar/Width	64f	Setting for width of calibration bar (mm).

SENSORS / SENSOR

Each Sensor element contains settings related to an individual sensor. A Sensor element has an attribute that defines the role (0 – Main, 1 – Buddy) of the sensor:

```
<Sensor role="0">
```

SENSORS / SENSOR / PROFILING

Profiling Child Elements

Element	Type	Description
ExposureMode	32u	Setting for exposure mode: 0 – Single exposure 1 – Multiple exposures 2 – Dynamic exposure
ExposureDelay	32u	Setting for an optional delay (us) between triggering event and the actual start of the exposure. This is used for time multiplexing the sensors in a multi-sensor system.
Exposure	64f	Setting for exposure (us).
DynamicExposureMax	64f	Setting for maximum exposure (for dynamic exposure).
DynamicExposureMin	64f	Setting for minimum exposure (for dynamic exposure).
ActiveAreaZ	64f	Setting for active area clearance distance (mm).
ActiveAreaHeight	64f	Setting for active area measurement range (mm).
ZSubsampling	32u	Setting for Z resolution divider.
ExposureMin	64f	Constraint for minimum exposure (us).
ExposureMax	64f	Constraint for maximum exposure (us).
ActiveAreaZMax	64f	Constraint for maximum Z field of view boundary (mm).
ActiveAreaZMin	64f	Constraint for minimum Z field of view boundary (mm).
ActiveAreaHeightMin	64f	Constraint for minimum field of view height (mm).
ActiveAreaHeightMax	64f	Constraint for maximum field of view height (mm).
ZSubsamplingOptions	String	Constraint for z resolution divider options – comma delimited list (e.g. "1,2").
FrontCameraX	32u	Property for x position of image ROI (pixels).
FrontCameraY	32u	Property for y position of image ROI (pixels).
FrontCameraWidth	32u	Property for width of image ROI (pixels).
FrontCameraHeight	32u	Property for height of image ROI (pixels).
CalibratedZ	64f	Property for sensor calibrated active area Z position (mm).
CalibratedHeight	64f	Property for sensor calibrated active area height (mm).

Range

The Range element contains settings that affect range measurements. Simple child elements in Range are defined below:

Range Child Elements

Element	Type	Description
MeasurementOptions	String	Constraint for available measurement types - comma delimited list (e.g. "RangePositionZ, RangeDifference").

The Range element also contains the Measurement sub-element. The Measurements element contains one sub-element for each requested range measurement.

The id attribute associated with each measurement defines an identifier that must be unique among all measurements in the configuration file.

e.g. <width id="1001">

MEASUREMENTS / RANGEPOSITIONZ

A RangePositionZ element defines settings for a range position-z measurement.

RangePositionZ Child Elements

Element	Type	Description
Name	String	Setting for measurement name.
Source	32s	Setting for range source.
DecisionMin	64f	Setting for decision threshold minimum (mm).
DecisionMax	64f	Setting for decision threshold maximum (mm).
SmoothingEnabled	32u	Setting to enable or disable the smoothing filter: 0 – Disable 1 – Enable
SmoothingWindow	32u	Setting for the smoothing window (frames)
HoldEnabled	32u	Setting to enable or disable the hold filter: 0 – Disable 1 – Enable
SourceOptions	String	Constraint for eligible range sources (comma-delimited list).
SmoothingWindowMin	32u	Constraint for smoothing window minimum (frames)
SmoothingWindowMax	32u	Constraint for smoothing window maximum (frames)

MEASUREMENTS / RANGEDIFFERENCE

A RangeDifference element defines settings for a range difference measurement.

RangeDifference Child Elements

Element	Type	Description
Name	String	Setting for measurement name.
Source	32s	Setting for range source.
DecisionMin	64f	Setting for decision threshold minimum (mm).
DecisionMax	64f	Setting for decision threshold maximum (mm).
AbsoluteResult	32u	Setting for selecting absolute or signed result: 0 – Signed result 1 – Absolute result

Element	Type	Description
SmoothingEnabled	32u	Setting to enable or disable the smoothing filter: 0 – Disable 1 – Enable
SmoothingWindow	32u	Setting for the smoothing window (frames)
HoldEnabled	32u	Setting to enable or disable the hold filter: 0 – Disable 1 – Enable
SourceOptions	String	Constraint for eligible range sources (comma-delimited list).
SmoothingWindowMin	32u	Constraint for smoothing window minimum (frames)
SmoothingWindowMax	32u	Constraint for smoothing window maximum (frames)

MEASUREMENTS / SCRIPT

A Script element defines settings for a script measurement.

Script Child Elements

Element	Type	Description
Name	String	Setting for measurement name.
Code	String	Script code.

Output

The Outputs element has the following sub-element types: Ethernet, Serial, Analog, and Digital Output. Each of these subelements defines the output settings for a different type of Gocator output.

The *Source* identifiers that are used with *Video*, *range* and *intensity* outputs are *range source identifiers*. Refer to the Range Sources (page 127) for more information.

The *Source* identifiers that are used with *Value* and *Decision* outputs correspond to the measurement identifiers defined in the Measurements element. E.g.

```
<RangeMeasurement>
  ...
  <Measurements>
    <RangePositionZ id="1000">
      ...
    <RangeDifference id="2000">
      ...
  ...
</RangeMeasurement>
<Outputs>
  <Ethernet>
    ...
    <Decision>1000,2000</Decision>
    ...
  ...
</Outputs>
```

ETHERNET

The Ethernet element defines settings for Ethernet output.

Ethernet Child Elements

Element	Type	Description
Protocol	32s	Setting for selected protocol: 0 – Gocator 1 – Modbus TCP 2 – EtherNet/IP
Video	String	Setting for selected video sources (comma-delimited list).
Range	String	Setting for selected range sources (comma-delimited list).
RangeIntensity	String	Setting for selected range intensity sources (comma-delimited list).
Value	String	Setting for selected value sources (comma-delimited list).
Decision	String	Setting for selected decision sources (comma-delimited list).
AsciiOperation	32s	Setting for the ASCII protocol operation mode: 0 – Asynchronous 1 – Polling
AsciiControlPort	32u	Setting for the ASCII protocol control channel port number.
AsciiHealthPort	32u	Setting for the ASCII protocol health channel port number.
AsciiDataPort	32u	Setting for the ASCII protocol data channel port number.
AsciiDelimiter	String	Setting for the ASCII protocol delimiter character.
AsciiTerminator	String	Setting for the ASCII protocol terminator character.
AsciiInvalidValue	String	Setting for the ASCII protocol invalid value string
AsciiCustomFormatEnabled	32u	Setting for the ASCII custom format 0 – Disable 1 – Enable
AsciiCustomDataFormat	String	Setting for the format of ASCII custom data string.
RangeOptions	String	Constraint for eligible range sources (comma-delimited list).
RangeIntensityOptions	String	Constraint for eligible range intensity sources (comma-delimited list).
ValueOptions	String	Constraint for eligible value sources (comma-delimited list).
DecisionOptions	String	Constraint for eligible decision sources (comma-delimited list).

SERIAL

The Serial element defines settings for Serial output.

Serial Child Elements

Element	Type	Description
Value	String	Setting for selected value sources (comma-delimited list).
Decision	String	Setting for selected decision sources (comma-delimited list).
Protocol	32s	Setting for the serial protocol: 0 – Gocator 1 – Selcom Serial
SelcomRate	32u	Setting for Selcom Serial output rate (bits/s)
SelcomFormat	32s	Setting for Selcom Serial output format: 0 – 14-bit 1 – 14-bit with search/track information 2 – 12-bit 3 – 12-bit with search/track information
AsciiDelimiter	String	Setting for the ASCII protocol delimiter character.
AsciiTerminator	String	Setting for the ASCII protocol terminator character.
AsciiInvalidValue	String	Setting for the ASCII protocol invalid value string
AsciiCustomFormatEnabled	32u	Setting for the ASCII custom format 0 – Disable 1 – Enable
AsciiCustomDataFormat	String	Setting for the format of ASCII custom data string.
ValueOptions	String	Constraint for eligible value sources (comma-delimited list).
DecisionOptions	String	Constraint for eligible decision sources (comma-delimited list).
ProtocolOptions	String	Constraint for eligible protocol options (comma-delimited list)
SelcomRateOptions	String	Constraint for Selcom Serial rate options (comma-delimited list)
SelcomFormatOptions	String	Constraint for Selcom Serial format options (comma-delimited list)

ANALOG

The Analog element defines settings for Analog output.

The range of valid measurement values [DataScaleMin, DataScaleMax] is scaled linearly to the specified current range [CurrentMin, CurrentMax].

Only one Value or Decision source can be selected at a time.

Analog Child Elements

Element	Type	Description
CurrentMin	64f	Setting for minimum output current (mA).
CurrentMax	64f	Setting for maximum output current (mA).
CurrentInvalid	64f	Setting for invalid output current (mA).
CurrentInvalidEnable	32u	0 – Output keeps currently value if measurement is invalid. 1 – Outputs CurrentInvalid if measurement is invalid.
DataScaleMin	64f	Setting for measurement value associated with the minimum current.
DataScaleMax	64f	Setting for measurement value associated with the maximum current.
Value	32u	Setting for selected value source.
Decision	32u	Setting for selected decision source.
CurrentLimitMin	64f	Constraint for minimum output current (mA).
CurrentLimitMax	64f	Constraint for maximum output current (mA).
ValueOptions	String	Constraint for eligible value sources (comma-delimited list).

Element	Type	Description
DecisionOptions	String	Constraint for eligible decision sources (comma-delimited list).
Event	32s	Setting for which event control the output: 1 – Measurement 2 – Software
ScheduleEnable	32u	Setting for scheduled output mode. When unscheduled, output updates immediately. When scheduled, output updates according to a target value in software command, or a delay. 0 – Not scheduled 1 – Scheduled
Delay	64f	Setting for output delay. The delay is measured from exposure (first exposure for multiple exposure) to when output is scheduled. Ignored when ScheduleEnable is 0. The units depends on SystemDomain.

The delay specifies the time or position at which the analog output activates. Upon activation, there is an additional delay before the analog output settles at the correct value.

DIGITAL OUTPUT

A DigitalOutput element defines settings for a digital output. There are two DigitalOutput elements, each identified by a unique id attribute (0 and 1):

```
<DigitalOutput id="0">
```

DigitalOutput Child Elements

Element	Type	Description
PassMode	32u	Setting to specify how the state of the output is defined: 0 – Pass if decision is true 1 – Pass if decision is false 2 – Pass always
PulseWidth	32u	Setting for digital pulse width (us).
Decision	String	Setting for selected decision sources (comma-delimited list).
PulseWidthMin	32u	Constraint for minimum pulse width (us).
PulseWidthMax	32u	Constraint for maximum pulse width (us).
DecisionOptions	String	Constraint for eligible decision sources (comma-delimited list).
SignalType	32s	Setting for signal type: 0 – Pulsed output 1 – Continuous output
Event	32s	Setting for which event control the output: 1 – Measurement 2 – Software 4 – Exposure
ScheduleEnable	32u	Setting for scheduled output mode. When unscheduled, output updates immediately. When scheduled, output updates according to a target value in software command, or a delay. 0 - Not scheduled 1 - Scheduled
Delay	64f	Setting for output delay. The delay is measured from exposure (first exposure for multiple exposure) to when output is scheduled. Ignored when ScheduleEnable is 0. The units depends on SystemDomain.

Calibration File

The calibration file, transform.xml, contains settings that define the transformation from sensor coordinates to system coordinates, encoder resolution and distance (in direction of travel) between main and buddy sensor.

Use Read and Write File command to modify the calibration file.

Calibration Example:

```
<?xml version="1.0" ?>
<SysCal version="1">
  <YDomain>0</YDomain>
  <YResolution>0</YResolution>
  <YSpeed>0</YSpeed>
  <Entries>
    <Entry id="0">
      <X>-2.3650924829</X>
      <Y>0</Y>
      <Z>123.4966803469</Z>
      <Roll>5.7478302588</Roll>
      <Pitch>0</Roll>
      <Yaw>0</Yaw>
      <Orientation>0</Orientation>
    </Entry>
    <Entry id="1">
      <X>0</X>
      <Y>0</Y>
      <Z>123.4966803469</Z>
      <Roll>2.5</Roll>
      <Pitch>0</Roll>
      <Yaw>0</Yaw>
      <Orientation>0</Orientation>
    </Entry>
  </Entries>
</SysCal>
```

SysCal

The SysCal element contains the calibration record for both main and buddy sensor. The version attribute defines the version of the record format.

```
<SysCal version="1">
```

SysCal Child Elements

Element	Type	Description
YResolution	64f	Encoder Resolution (mm/tick).
YSpeed	64f	Travel Speed (mm/s).

ENTRIES

An Entry element defines the transformation for a sensor. There is one entry element per sensor, identified by a unique id attribute (0 for main and 1 for buddy):

```
<Entry id="0">
```

Entry Child Elements

Element	Type	Description
X	64f	Translation in the X axis (mm).
Y	64f	Translation in the Y axis (mm).
Z	64f	Translation in the Z axis (mm).
Roll	64f	Rotation about Y axis (degrees).
Pitch	64f	Rotation about X axis (degrees).
Yaw	64f	Rotation about Z axis (degrees).
Orientation	32u	Direction of X-axis: 0 – Normal 1 – Reverse

Gocator Protocol

This chapter describes TCP and UDP commands and data formats used by a client computer to communicate with Gocator sensors. Network communication enables the client to:

- Discover Main and Buddy sensors on an IP network and re-configure their network addresses.
- Configure Main and Buddy sensors.
- Send commands to run sensors, provide software triggers, read/write files, etc.
- Receive data, health, and diagnostic messages.
- Upgrade firmware.

The Concepts section in this chapter defines network connection types (Discovery, Control, Upgrade, Data, Health), common data types, and other terminologies. Subsequent sections provide details about network commands and data formats.

 The Gocator SDK provides open-source C language libraries that implement the network commands and data formats defined in this chapter. For more information, refer to Software Development Kit (page 186). .

Concepts

Discovery

Sensors ship with the following default network configuration:

Setting	Default
DHCP	0 (disabled)
IP Address	192.168.1.10
Subnet Mask	255.255.255.0
Gateway	0.0.0.0 (disabled)

The Get Address and Set Address discovery commands can be used to modify a sensor's network configuration. Discovery commands are UDP broadcast messages:

Destination Address	Destination Port
255.255.255.255	3220

When a sensor accepts a discovery command, it will send an UDP broadcast response:

Destination Address	Destination Port
255.255.255.255	Port of command sender.

The use of UDP broadcasts for discovery enables a client computer to locate a sensor when the sensor and client are configured for different subnets. All you need to know is the serial number of the sensor in order to locate it on an IP network.

Command Channels

A client can send commands and receive responses over the Control and Upgrade TCP channels.

Command Channels

Channel	Port	Description
Control	3190	Sensor accepts commands for most operations.
Upgrade	3192	Sensor accepts commands for firmware upgrades.

The Control and Upgrade channels can be connected simultaneously, but the sensor will accept only a single connection on each port. If an additional connection is attempted on a port that is already connected, the previous connection will be closed and the new connection will be accepted.

Result Channels

A client can receive data messages from a Gocator sensor by connecting to the Data or Health TCP channels.

Result Channels

Channel	Port	Description
Data	3196	Sensor sends data messages.
Health	3194	Sensor sends health messages.

The above ports can be connected simultaneously and the sensor will also accept multiple connections on each port.

Modes

A Gocator system can operate in the following modes.

System Modes

Mode	Description
Video	Sends raw video.
AlignCalibrate	Performs alignment calibration.
TravelCalibrate	Performs travel calibration.
ExpCalibrate	Performs automatic exposure adjustment.
RangeMeasure	Performs displacement measurements (default mode)

Buddy Communication Channels

The peer-to-peer control channels are used by Gocator sensors to communicate amongst each other.

Channel	Port	Description
Discovery	2002, 2005, 2008	Gocator peer discovery port. UDP broadcasts on the subnet is sent once every second.
Command	2002 to 2015	Gocator request and response ports. Gocator uses UDP communications on these ports for configuration and reporting.
Data	2500	Main Gocator listens on this port for TCP traffic from the Buddy sensor. Buddy sensor communicates using a free port available at the time.

States

A Gocator system can be in one of three states: Conflict, Ready, or Running. The Start and Stop commands are sent by the client to change the current state. The sensor can be configured to boot in either the Ready or Running state.

In the Ready state, a sensor can be configured. In the Running state, a sensor will respond to input signals, perform measurements, drive its outputs, and send data messages to the client. Disconnecting to command channel will change the sensor from the Running state to the Ready state.

The conflict state indicates that a sensor has been configured with a Buddy sensor but the Buddy sensor is not present on the network. The sensor will not accept some commands until the Change Buddy command is used to remove the configured Buddy.

Versions and Upgrades

Upon connection to a Gocator device, the *Get Protocol Version* and *Get System Info* commands can be used to establish protocol and firmware versions.

Versions

Version	Description
Protocol version	Sensor protocol version (major, minor).
Firmware version	Sensor firmware version (major, minor, release, build).

The *protocol version* refers to the version of the Gocator Protocol supported by the *connected sensor* (the sensor to which a command connection is established), and consists of major and minor parts. The minor part is updated when backward-compatible additions are made to the Gocator Protocol. The major part will be updated in the event that breaking changes are made to the Gocator Protocol.

The *firmware version* refers to the version of the Gocator's firmware installed on each individual sensor. The client can upgrade the Gocator's firmware by sending the Upgrade command. Firmware upgrade

files are available from the downloads section under the support tab on the LMI web site. Refer to Firmware Upgrade (page 112) for more information on obtaining the latest firmware.

Every Gocator sensor contains factory backup firmware. Should a firmware upgrade command fail (e.g. power is interrupted), the factory backup firmware will be loaded when the sensor is reset or re-powered. In this case, the sensors will fall back to the factory default IP address. To avoid IP address conflicts in a multi-sensor system, connect to one sensor at a time and re-attempt the firmware upgrade.

Data Types

The table below defines the data types and associated type identifiers used throughout this document. All values are transmitted in little endian format (least significant byte first) unless stated otherwise.

Data Types

Type	Id	Description
8u	1	8-bit unsigned integer.
8s	2	8-bit signed integer.
16u	3	16-bit unsigned integer.
16s	4	16-bit signed integer.
32u	5	32-bit unsigned integer.
32s	6	32-bit signed integer.
64u	7	64-bit unsigned integer.
64s	8	64-bit signed integer.
byte	9	1 Byte.
char	10	8-bit ASCII-encoded character.
64f	11	64-bit floating point value.
32f	12	32-bit floating point value.

 IP addresses are a notable exception to the little endian rule – the bytes in the address “a.b.c.d” will always be transmitted in the order a, b, c, d (big endian)..

Range Sources

Range data is always associated with a *range source*. The range source identifies the scope and nature of the laser range information.

Range Sources

Range Source	Id	Description
Main	0	Data from the Main sensor
Buddy	1	Data from the Buddy sensor
Combined	100	Combined data from the Main and Buddy sensor (for wide orientation)
Sensor	X	Data from an individual sensor, where X is the sensor serial number.

Status Codes

Each reply on the Discovery, Control, and Upgrade channels contains a status code indicating the result of the command. The following status codes are defined.

Status Codes

Label	Value	Description
OK	1	Command succeeded.

Label	Value	Description
Failed	0	Command failed.
Invalid State	-1000	Command is not valid in the current state.
Item Not Found	-999	A required item (e.g. file) was not found.
Invalid Command	-998	Command is not recognized.
Invalid Parameter	-997	One or more command parameters are incorrect.
Not Supported	-996	The operation is not supported.

Command and Reply Formats

Commands and replies that are sent and received on the Control and Upgrade channels each begin with a common header.

Command Header

Field	Type	Description
length	64s	Command size, in bytes.
id	64s	Command identifier.

Reply Header

Field	Type	Description
length	64s	Reply size, in bytes.
id	64s	Reply identifier (same as command identifier, unless otherwise noted).
status	64s	Reply status.

 Length fields prepended to the beginning of each message refer to the size of the entire message including the length field itself. For example, the value of the length field for a command that consists of only the header (no additional fields) would be 16.

Result Format

Result messages that are received on the Data and Health channels have a common structure. Each result message has a flexible number of attributes in its header followed by a variable number of data blocks after the header. The structure of result messages is defined below.

Result

Field	Type	Description
length	64s	Message length, in bytes.
id	64s	Message type identifier.
attributeCount	64s	Count of attributes in this message.
dataCount	64s	Count of data blocks in this message.
attributes[N]	64s	List of attributes specific to a particular message type.
descriptors[M]	Descriptor	List of data block descriptors (one per data block - format defined below).
blocks[M]	-	List of data blocks specific to a particular message type.

Block Descriptor

Field	Type	Description
length0	64s	Length of block dimension 0.
length1	64s	Length of block dimension 1.
length2	64s	Length of block dimension 2.
type	Type	Data type of block elements - refer to Data Types (page 127).

Each data block is an array of primitive values with 1, 2, or 3 dimensions and is described by an accompanying descriptor. The first *length* field that contains a zero determines the dimensionality of the block. For example, the length 2 field will contain zero for a 2 dimensional block. Items in the highest numbered dimension are transmitted sequentially.

Specific result messages, described later in this chapter, are defined by identifying the attributes and data block formats necessary to express the message content.

Discovery Commands

Get Address

The Get Address command is used to discover Gocator sensors across subnets.

Command

Field	Type	Description
length	64s	Command size, in bytes.
id	64s	Command identifier (0x0001)
signature	64s	Magic number (0x0000504455494D4C).
identifier	64s	Device identifier (serial number) or zero to discover unknown devices.

Reply

Field	Type	Description
length	64s	Reply size, in bytes.
id	64s	Reply identifier (0x1001).
status	64s	Reply status.
signature	64s	Magic number (0x0000504455494D4C).
deviceId	64s	Device identifier.
useDhcp	64s	1 if network interface uses DHCP, 0 otherwise.
reserved[4]	byte	Reserved.
address[4]	byte	IP address.
reserved[4]	byte	Reserved.
mask[4]	byte	Subnet mask.
reserved[4]	byte	Reserved.
gateway[4]	byte	Gateway.
reserved[4]	byte	Reserved.
reserved[4]	byte	Reserved.

Set Address

The Set Address command modifies the network configuration of a Gocator sensor. Upon receiving the command, the Gocator will perform a reset. User should wait for 30 seconds before re-connecting to the Gocator.

Command

Field	Type	Description
length	64s	Command size, in bytes.
id	64s	Command identifier (0x0002).
signature	64s	Magic number (0x0000504455494D4C).
deviceld	64s	Device identifier (serial number).
useDhcp	64s	1 if network interface uses DHCP, 0 otherwise.
reserved[4]	byte	Reserved. Set to 0.
address[4]	byte	IP address.
reserved[4]	byte	Reserved. Set to 0.
mask[4]	byte	Subnet mask.
reserved[4]	byte	Reserved. Set to 0.
gateway[4]	byte	Gateway.
reserved[4]	byte	Reserved. Set to 0.
reserved[4]	byte	Reserved. Set to 0.

Reply

Field	Type	Description
length	64s	Reply size – in bytes.
id	64s	Reply identifier (0x1002).
status	64s	Reply status.
signature	64s	Magic number (0x0000504455494D4C).
deviceld	64s	Device identifier.

Upgrade Commands

Get Protocol Version

The Get Protocol Version command reports the Upgrade protocol version of the connected sensor.

Command

Field	Type	Description
length	64s	Command size – in bytes.
id	64s	Command identifier (0x0100).

Reply

Field	Type	Description
length	64s	Reply size – in bytes.
id	64s	Reply identifier.
status	64s	Reply status.
majorVersion	64s	Major version.
minorVersion	64s	Minor version.

Start Upgrade

The Start Upgrade command begins a firmware upgrade for the main sensor and any Buddy sensors. All sensors will automatically reset 3 seconds after upgrade process is complete.

Command

Field	Type	Description
length	64s	Command size – in bytes.
id	64s	Command identifier (0x0000).
fileSize	64s	Upgrade file size – in bytes.
file[fileSize]	byte	Upgrade file.

Reply

Field	Type	Description
length	64s	Reply size – in bytes.
id	64s	Reply identifier.
status	64s	Reply status.

Get Upgrade Status

The Get Upgrade Status command determines the progress of a firmware upgrade.

Command

Field	Type	Description
length	64s	Command size – in bytes.
id	64s	Command identifier (0x0001).

Reply

Field	Type	Description
length	64s	Reply size – in bytes.
id	64s	Reply identifier.
status	64s	Reply status.

Field	Type	Description
stage	64s	Current upgrade stage: -1 – Upgrade Failed 0 – Upgrade Completed 1 – Upgrade in Progress
progress	64s	Percentage completed – valid when stage is Upgrade in Progress.

Get Upgrade Log

The Get Upgrade Log command can retrieve an upgrade log in the event of upgrade problems.

Command

Field	Type	Description
length	64s	Command size – in bytes.
id	64s	Command identifier (0x0002).

Reply

Field	Type	Description
length	64s	Reply size – in bytes.
id	64s	Reply identifier.
status	64s	Reply status.
fileSize	64s	Log file size – in bytes.
file[fileSize]	byte	Log file.

Control Commands

Get Protocol Version

The Get Protocol Version command reports the Control protocol version of the connected sensor.

Command

Field	Type	Description
length	64s	Command size – in bytes.
id	64s	Command identifier (0x4511).

Reply

Field	Type	Description
length	64s	Reply size – in bytes.
id	64s	Reply identifier.
status	64s	Reply status.
majorVersion	64s	Major version.
minorVersion	64s	Minor version.

Get System Info

The Get System Info command reports information for sensors that are visible in the system.

Command

Field	Type	Description
length	64s	Command size – in bytes.
id	64s	Command identifier (0x4002).

Reply

Field	Type	Description
length	64s	Reply size – in bytes.
id	64s	Reply identifier.
status	64s	Reply status.
deviceld	64s	Connected sensor device id (serial number).
firmwareVersion	64s	Connected sensor firmware version.
modelName[32]	char	Connected sensor model name (null-terminated).
role	64s	Connected sensor network role: 0 – Standalone 1 – Main (in a Buddy setup) 2 – Buddy
loginState	64s	Authenticated user: 0 – None 1 – Administrator 2 – Technician
systemState	64s	Current system state: 1 – Conflict 2 – Ready 3 – Running

Field	Type	Description
calibrationType	64s	Current calibration state: 0 – Not calibrated 1 – Auto calibrated 2 – Manual calibrated
hasBuddy	64s	Current buddy assignment state: 0 – No Buddy assigned 1 – Buddy assigned
BuddyInfo	BuddyInfo	Assigned Buddy information (not present if hasBuddy is 0).
sensorCount	64s	Count of visible sensors.
sensorInfo[sensorCount]	SensorInfo	Sensor Information (see format below).

BuddyInfo

Field	Type	Description
deviceId	64s	Buddy device id.
state	64s	Sensor Buddy state: 0 – Connected 1 – Missing 2 – Error
modelName[32]	char	Sensor model name.
firmwareVersion	64s	Buddy firmware version.

SensorInfo

Field	Type	Description
deviceId	64s	Sensor device id.
state	64s	Sensor state: 0 – Paired (not set for main sensor) 1 – Available 2 – Unavailable
modelName[32]	char	Sensor model name (null-terminated).
firmwareVersion	64s	Sensor firmware version.

Log In/Out

The Log In/Out command is used to log in or out of a sensor.

Command

Field	Type	Description
length	64s	Command size – in bytes.
id	64s	Command identifier (0x4003).
userType	64s	User account: 0 – None (log out) 1 – Administrator 2 – Technician
password[64]	char	Password (null-terminated; required for log-in only).

Reply

Field	Type	Description
length	64s	Reply size – in bytes.
id	64s	Reply identifier.
status	64s	Reply status.

Change Password

The Change Password command is used to change log-in credentials for a user.

Command

Field	Type	Description
length	64s	Command size – in bytes.
id	64s	Command identifier (0x4004).
user type	64s	User account: 1 – Administrator 2 – Technician
password[64]	char	New password (null-terminated).

Reply

Field	Type	Description
length	64s	Reply size – in bytes.
id	64s	Reply identifier.
status	64s	Reply status.

Change Buddy

The Change Buddy command is used to assign or unassign a Buddy sensor.

Command

Field	Type	Description
length	64s	Command size - in bytes.
id	64s	Command identifier (0x4005).
action	64s	Action to take: 0 – Unassign Buddy. 1 – Assign Buddy.
count	64s	Count of sensors affected by action (must be 1 at present).
deviceid[count]	64s	List of target sensors.

Reply

Field	Type	Description
length	64s	Reply size - in bytes.
id	64s	Reply identifier.
status	64s	Reply status.

Get File List

The Get File List command reports the list of available files on the connected sensor.

Command

Field	Type	Description
length	64s	Command size - in bytes.
id	64s	Command identifier (0x101A).
extension[64]	char	Null-terminated file extension filter, or empty: cfg – Configuration files rec – Record/Playback data files xml – XML file

Reply

Field	Type	Description
length	64s	Reply size – in bytes.
id	64s	Reply identifier.
status	64s	Reply status.
count	64s	Number of file names returned.
name[count][64]	char	List of file names.

Copy File

The Copy File command copies a file from a source to a destination within the connected sensor. Copy a saved configuration to "_live.cfg" to make the configuration live. Copy a saved template to "_live.prof" to make the template live.

Command

Field	Type	Description
length	64s	Command size – in bytes.
id	64s	Command identifier (0x101B).
source [64]	char	Source file name (null-terminated).
destination [64]	char	Destination file name (null-terminated).

Reply

Field	Type	Description
length	64s	Reply size – in bytes.
id	64s	Reply identifier.
status	64s	Reply status.

Read File

Downloads a file from the connected sensor. Read the file "_live.cfg" and "_live.prof" to down the live configuration and template.

Command

Field	Type	Description
length	64s	Command size – in bytes.
id	64s	Command identifier (0x1007).
fileName[64]	char	File name (null-terminated).

Reply

Field	Type	Description
length	64s	Reply size – in bytes.
id	64s	Reply identifier.
status	64s	Reply status.
fileSize	64s	File size – in bytes.
file[fileSize]	byte	File content.

Write File

The Write File command uploads a file to the connected sensor. Write to "_live.cfg" and "_live.prof" to write the make the configuration and template files live. Except for writing to the live files, the file is permanently stored on the sensor.

Command

Field	Type	Description
length	64s	Command size – in bytes.
id	64s	Command identifier (0x1006).
fileName[64]	char	File name (null-terminated).
fileSize	64s	File size – in bytes.
file[fileSize]	byte	File content.

Reply

Field	Type	Description
length	64s	Reply size – in bytes.
id	64s	Reply identifier.
status	64s	Reply status.

Delete File

The Delete File command removes a file from the connected sensor.

Command

Field	Type	Description
length	64s	Command size – in bytes.
id	64s	Command identifier (0x1008).
fileName[64]	char	File name (null-terminated).
fileSize	64s	File size – in bytes.
file[fileSize]	byte	File content.

Reply

Field	Type	Description
length	64s	Reply size – in bytes.
id	64s	Reply identifier.
status	64s	Reply status.

Get Default File

The Get Default File command gets the name of a default file that will be loaded at boot time. Default files can be defined for configuration and calibration (differentiated by extension).

Command

Field	Type	Description
length	64s	Command size – in bytes.
id	64s	Command identifier (0x4100).
extension[64]	char	Null-terminated file extension: cfg – Configuration files rec – Record/Playback data files

Reply

Field	Type	Description
length	64s	Reply size – in bytes.
id	64s	Reply identifier.
status	64s	Reply status.
fileName[64]	char	File name (null-terminated).

Set Default File

The Set Default File command sets the name of a default file that will be loaded at boot time. Default files can be defined for configuration and calibration.

Command

Field	Type	Description
length	64s	Command size – in bytes.
id	64s	Command identifier (0x4101).
fileName[64]	char	File name (null-terminated), including the extension. cfg – Configuration files rec – Record/Playback data files

Reply

Field	Type	Description
length	64s	Reply size – in bytes.
id	64s	Reply identifier.
status	64s	Reply status.

Get Loaded File

The Get Loaded File command returns the currently loaded (i.e. live) file name and modified status for a file type.

Command

Field	Type	Description
length	64s	Command size – in bytes.
id	64s	Command identifier (0x4512).
extension[64]	char	Extension for the file type: cfg – Configuration files

Reply

Field	Type	Description
length	64s	Reply size – in bytes.
id	64s	Reply identifier.
status	64s	Reply status.
fileName[64]	char	Name of the currently loaded file.
changed	64	Whether or not the currently loaded file has been changed (1: yes; 0: no).

Get Mode

The Get Mode command reports the name of the current system mode.

Command

Field	Type	Description
length	64s	Command size – in bytes.
id	64s	Command identifier (0x1005).

Reply

Field	Type	Description
length	64s	Reply size – in bytes.
id	64s	Reply identifier.

Field	Type	Description
status	64s	Reply status.
mode[16]	char	Mode name (null-terminated).

Set Mode

The Set Mode command sets the name of the current system mode.

Command

Field	Type	Description
length	64s	Command size – in bytes.
id	64s	Command identifier (0x1004).
mode[16]	char	Mode name (null-terminated).

Reply

Field	Type	Description
length	64s	Reply size – in bytes.
id	64s	Reply identifier.
status	64s	Reply status.

Get Time

This command retrieves the system clock, in microseconds. All devices in a system are synchronized with the system clock; this value can be used for diagnostic purposes, or used to synchronize the start time of the system.

Command

Field	Type	Description
length	64s	Command size – in bytes.
id	64s	Command identifier (0x100A).

Reply

Field	Type	Description
length	64s	Reply size – in bytes.
id	64s	Reply identifier (0x100A).
status	64s	Reply status.
time	64u	Current time, in microseconds.

Get Encoder

This command retrieves the current system encoder value.

Command

Field	Type	Description
length	64s	Command size – in bytes.
id	64s	Command identifier (0x101C).

Reply

Field	Type	Description
length	64s	Reply size – in bytes.
id	64s	Reply identifier (0x101C).
status	64s	Reply status.

Field	Type	Description
encoder	64s	Current encoder value, in ticks.

Start

The Start command starts the sensor system (system enters the Running state).

Command

Field	Type	Description
length	64s	Command size – in bytes.
id	64s	Command identifier (0x100D).
reserved	64s	Reserved field – set to 0.

Reply

Field	Type	Description
length	64s	Reply size – in bytes.
id	64s	Reply identifier.
status	64s	Reply status.

Scheduled Start

The scheduled start command starts the sensor system (system enters the Running state) at target time or encoder value (depending on the trigger mode).

The time and encoder targets value should be set by adding a delay to the time and/or encoder tick returned by Get Time and Get Encoder command. The delay should be set such that it covers the command response time of the Scheduled start command.

Command

Field	Type	Description
length	64s	Command size – in bytes.
id	64s	Command identifier (0x101D).
time target	64s	Specify start time target, in microseconds.
encoder target	64s	Specify start encoder target in ticks.

Reply

Field	Type	Description
length	64s	Reply size – in bytes.
id	64s	Reply identifier (0x101D).
status	64s	Reply status.

Stop

The Stop command stops the sensor system (system enters the Ready state).

Command

Field	Type	Description
length	64s	Command size – in bytes.
id	64s	Command identifier (0x1001).

Reply

Field	Type	Description
length	64s	Reply size – in bytes.
id	64s	Reply identifier.
status	64s	Reply status.

Trigger

The Trigger command applies a software trigger to the system. The system must be configured to accept software triggers and must be in the Running State.

Command

Field	Type	Description
length	64s	Command size – in bytes.
id	64s	Command identifier (0x4510).

Reply

Field	Type	Description
length	64s	Reply size – in bytes.
id	64s	Reply identifier.
status	64s	Reply status.

Scheduled Digital Output

The Scheduled Digital Output command schedules a digital output event. The digital output must be configured to accept software scheduled command and is in the Running State. Refer to Digital Outputs (page 87) on how to setup the digital output.

Command

Field	Type	Description
length	64s	Command size – in bytes.
id	64s	Command identifier (0x4518).
index	64s	Index of the output (starts from 0)
target	64s	Specifies the time (us) or position (encoder ticks) of when the event should happen.
value	64s	The target value is ignored if the Signal type in the Digital Output panel is not set to scheduled. The output will be triggered immediately. Refer to Digital Outputs (page 87) for how to set the Signal type. Specifies the target state: 0 – Set to low (continuous) 1 – Set to high (continuous) Ignored if output type is pulsed.

Reply

Field	Type	Description
length	64s	Reply size – in bytes.
id	64s	Reply identifier.
status	64s	Reply status.

Scheduled Analog Output

Scheduled Analog Output command schedules an analog output event. The analog output must be configured to accept software scheduled command and is in the Running State. Refer to Analog Output (page 90) on how to setup the digital output.

Command

Field	Type	Description
length	64s	Command size – in bytes.
id	64s	Command identifier (0x4519).
index	64s	Index of the output. Must be 0.
target	64s	Specifies the time (us) or position (encoder ticks) of when the event should happen. The target value is ignored if the Signal type in the Analog Output panel is not set to scheduled. The output will be triggered immediately. Refer to Analog Output (page 90) for how to set the Signal type.
value	64s	Output current (nano amperes).

Reply

Field	Type	Description
length	64s	Reply size – in bytes.
id	64s	Reply identifier.
status	64s	Reply status.

Note that the analog output takes about 75 us to reach 90% of the target value for a maximum change, then another ~40 us to settle completely.

Ping

The Ping command can be used to test the control connection. This command has no effect.

Command

Field	Type	Description
length	64s	Command size – in bytes.
id	64s	Command identifier (0x100E).
reserved	64s	Reserved – set to 0.

Reply

Field	Type	Description
length	64s	Reply size – in bytes.
id	64s	Reply identifier.
status	64s	Reply status.

Reset

The Reset command reboots the main sensor and any Buddy sensors. All sensors will automatically reset 3 seconds after the reply to this command is transmitted.

Command

Field	Type	Description
length	64s	Command size – in bytes.
id	64s	Command identifier (0x4300).

Reply

Field	Type	Description
length	64s	Reply size – in bytes.
id	64s	Reply identifier.
status	64s	Reply status.

Backup

The Backup command creates a backup of all files stored on the connected sensor and downloads the backup to the client.

Command

Field	Type	Description
length	64s	Command size – in bytes.
id	64s	Command identifier (0x1013).

Reply

Field	Type	Description
length	64s	Reply size – in bytes.
id	64s	Reply identifier.
status	64s	Reply status.
fileSize	64s	Size of backup file – in bytes.
file[fileSize]	byte	Backup file content.

Restore

The Restore command uploads a backup file to the connected sensor and then restores all sensor files from the backup.

Note that the sensor must be reset or power-cycled before the restore operation can be completed.

Command

Field	Type	Description
length	64s	Command size – in bytes.
id	64s	Command identifier (0x1014).
fileSize	64s	Size of backup file – in bytes.
file[fileSize]	byte	Backup file content.

Reply

Field	Type	Description
length	64s	Reply size – in bytes.
id	64s	Reply identifier.
status	64s	Reply status.

Restore Factory

The Restore Factory command restores the connected sensor to factory default settings. This command has no effect on connected Buddy sensors.

Note that the sensor must be reset or power-cycled before the factory restore operation can be completed.

Command

Field	Type	Description
length	64s	Command size – in bytes.
id	64s	Command identifier (0x4301).
resetAddress	64s	Specifies whether network address should be restored to default: 0 – Do not reset address 1 – Reset address

Reply

Field	Type	Description
length	64s	Reply size – in bytes.
id	64s	Reply identifier.
status	64s	Reply status.

Set Connection Type

The Set Connection Type command save the type of the master to the sensor's non-volatile storage.

Command

Field	Type	Description
length	64s	Command size – in bytes.
id	64s	Command identifier (0x4514).
type	64s	Connection type: 0 – None 1 – Master 100 2 – Master 200 3 – Master 400 4 – Master 800 5 – Master 1200 6 – Master 2400

Reply

Field	Type	Description
length	64s	Reply size – in bytes.
id	64s	Reply identifier.
status	64s	Reply status.

Get Connection Type

The Get Connection Type command returns to the set connection type.

Command

Field	Type	Description
length	64s	Command size – in bytes.
id	64s	Command identifier (0x4515).

Reply

Field	Type	Description
length	64s	Reply size – in bytes.
id	64s	Reply identifier.
status	64s	Reply status.
type	64s	Connection type (see Set Connection Type above).

Clear Calibration

The Clear calibration command deletes the calibration results.

Command

Field	Type	Description
length	64s	Command size – in bytes.
id	64s	Command identifier (0x4102).

Reply

Field	Type	Description
length	64s	Reply size – in bytes.
id	64s	Reply identifier.
status	64s	Reply status.

Data Results

A Data Result message adheres to the general structure for result messages as defined in Result Format (page 129)

A Data Result contains a variable number of blocks depending on the sources selected for Ethernet output. Each selected source contributes two data blocks (and accompanying data block descriptors): one block for attributes and one block for content such as video pixels or measurement results.

Data Result Header

Field	Type	Description
length	64s	Message length – in bytes.
id	64s	Message id (1).
attributeCount	64s	Count of attributes in this message header (7).
dataCount	64s	Count of data blocks in this message (variable).
reserved	64s	Reserved for internal use.
timestamp	64s	Timestamp (us).
encoder	64s	Encoder value (ticks).
frameCount	64s	Frame count.
digitalInputs	64s	Digital input states.
encoderIndex	64s	Encoder value when the last index is triggered.
reserved	64s	Reserved for internal use.
descriptors[dataCount]	Descriptor	List of data block descriptors.
data[dataCount]	-	List of data blocks.

The formats of the data blocks contributed from specific data sources are described in the following sections.

Video

Video Attributes

Field	Type	Description
dataType	64s	Data type (0x00).
source	64s	Video source.
width	64s	Image width (pixel).
height	64s	Image height (pixel).
type	64s	Pixel data type (0x00).
exposure	64s	Exposure (us).
reserved{N}	64s	A variable number of additional attributes may be included.

Video Data

Field	Type	Description
pixels[height][width]	Byte	Image pixels (dimensions and data type given by block descriptor).

Range

Range Attributes

Field	Type	Description
dataType	64s	Data type: 0xA – Range
source	64s	Range source.

Field	Type	Description
zResolution	64s	Z resolution (nm).
zOffset	64s	Z offset (nm).
exposure	64s	Exposure (us). Set to zero if multiple exposure mode is used.
reserved[N]	64s	A variable number of additional attributes may be included.

Data

Field	Type	Description
range	16s	Range values (unit is z-resolution, 0x8000 represents null range). Dimensions and data type given by block descriptor

Z system coordinate = zOffset + zResolution * range

Range Intensity

Range Intensity Attributes

Field	Type	Description
dataType	64s	Data type: 0xB – Range intensity
source	64s	Range source.
reserved[N]	64s	A variable number of additional attributes may be included.

Range Intensity Data (resampled or raw)

Field	Type	Description
intensityValue	8u	Range intensity values. A value of 0 indicates no spot.

Alignment Calibration

Alignment Calibration Attributes

Field	Type	Description
dataType	64s	Data type (0x04).
reserved[N]	64s	A variable number of additional attributes may be included.

Alignment Calibration Data

Field	Type	Description
status	64s	Calibration result.

Travel Calibration

Travel Calibration Attributes

Field	Type	Description
dataType	64s	Data type (0x05).
reserved[N]	64s	A variable number of additional attributes may be included.

Travel Calibration Data

Field	Type	Description
status	64s	Calibration result.

Exposure Calibration

Exposure Calibration Attributes

Field	Type	Description
dataType	64s	Data type (0x06).
reserved{N}	64s	A variable number of additional attributes may be included.

Exposure Calibration Data

Field	Type	Description
status	64s	Calibration result.
exposure	64s	Calibrated exposure (us).

Measurement

Measurement Attributes

Field	Type	Description
dataType	64s	Data type (0x21).
measurementType	64s	Measurement type: 0x80 – Position Z 0x81 – Difference 0x82 – Script
id	64s	Unique id of the measurement – as defined in the configuration.
reserved[N]	64s	A variable number of additional attributes may be included.

Measurement Data

Field	Type	Description
value	64s	Result value.
decision	64s	Result decision: 0 – Fail 1 – Pass

Health Results

A Health Result message adheres to the general structure for result messages as defined in Result Format (page 129)

A Health Result contains a single data block for health *indicators*. Each indicator reports the current status of some aspect of the sensor system, such as CPU utilization or network throughput.

Health Result Header

Field	Type	Description
length	64s	Message length, in bytes.
id	64s	Message id (1000).
attributeCount	64s	Count of attributes in this message header (1).
dataCount	64s	Count of data blocks in this message (1).
deviceId	64s	Sensor device id.
descriptors[dataCount]	Descriptor	List of data block descriptors.
data[dataCount]	-	List of data blocks.

The health data block contains a 2 dimensional array of indicator data. Each row in the array has the following format:

Health Indicator Format

Field	Type	Description
id	64s	Indicator identifier (indicators are defined below).
instance	64s	Indicator instance.
value	64s	Indicator value.

The following health indicators are defined for Gocator sensor systems:

Health Indicators

Indicator	Id	Instance	Value
Encoder Value	1003	-	Current system encoder tick.
Encoder Index	1004	-	Current system encoder index.
Encoder Frequency	1005	-	Current system encoder frequency (ticks/s).
Firmware Version	2000	-	Firmware application version.
Temperature	2002	-	Internal temperature (degrees Celsius).
Memory Used	2003	-	Amount of memory currently used (bytes).
Memory Capacity	2004	-	Total amount of memory available (bytes).
Storage Used	2005	-	Amount of non-volatile storage used (bytes).
Storage Capacity	2006	-	Total amount of non-volatile storage available (bytes).
CPU Used	2007	-	CPU usage (percentage of maximum).
Net Out Used	2008	-	Current outbound network throughput (bytes/s).
Net Out Capacity	2009	-	Total available outbound network throughput (bytes/s).
State	2010	-	Current system state.
Camera Errors	2011	-	Number of camera frame errors encountered.
Camera Drops	2012	-	Number of camera frames dropped.
Processing Drops	2015	-	Number of messages dropped before data processing.
Ethernet Drops	2016	-	Number of messages generated but not sent.
Uptime	2017	-	Time elapsed since boot-up or reset (seconds).
Speed	2018	-	Current speed (Hz).
Trigger Drops	2019	-	Number of dropped triggers.
Digital Output Drops	2020	Output index	Number of dropped digital outputs.

Indicator	Id	Instance	Value
Analog Output Drops	2021	Output Index	Number of dropped analog outputs.
Serial Output Drops	2022	Output index	Number of dropped serial outputs.
Laser Temperature	2023		Laser temperature (degrees Celsius). Only available on sensors equipped with 3B-N laser.
Digital Inputs	2024		Current status of digital input
Camera Frame Count	2025		Number of camera frames
Valid Frame Count	20000		Number of frames with valid range data.
Invalid Frame Count	20001		Number of frames without valid range data.
Digital Output Pass	20002	Output index	Number of pass digital output pulses.
Digital Output Fail	20003	Output Index	Number of fail digital output pulses.
Valid Spot Count	20006	–	Number of valid spots that are detected
Processing Latency	20007	–	Last delay from camera exposure to when results can be scheduled to Rich I/O.
Max Processing Latency	20008	–	Maximum delay from camera exposure to when results can be scheduled to Rich I/O. Reset on start.
Max Spot Count	20009	–	Maximum number of spots that can be detected.
Measurement	30000	Measurement id	Measurement value.
Measurement Pass	30001	Measurement id	Number of pass decisions.
Measurement Fail	30002	Measurement id	Number of fail decisions.
Measurement Minimum	30003	Measurement id	Minimum measurement value.
Measurement Maximum	30004	Measurement id	Maximum measurement value.
Measurement Average	30005	Measurement id	Average measurement value.
Measurement Stddev	30006	Measurement id	Standard deviation of measurement value.
Measurement Invalid Count	30007	Measurement id	Number of invalid values

 Additional undocumented indicator values may be included in addition to the indicators defined above.

Modbus TCP Protocol

Modbus TCP is designed to allow industrial equipment such as Programmable Logic Controllers (PLC), sensors and physical input/output devices to communicate over an Ethernet network.

Modbus/TCP embeds a Modbus frame into a TCP frame in a simple manner. This is a connection-oriented transaction and every query expects a response.

This chapter describes the Modbus TCP commands and data formats. Modbus TCP communication enables the client to:

- Switch to a different active configuration.
- Calibrate and run sensors.
- Receive sensor states, stamps and measurement results.

Modbus TCP is enabled in the Output panel. For more information, refer to Ethernet Control and Output (page 83).

Concepts

A PLC sends a command to start each Gocator. The PLC then periodically queries each Gocator for its latest measurement results. In Modbus terminology, the PLC is a Modbus Client. Each Gocator is a Modbus Server which serves the results to the PLC.

The Modbus TCP protocol uses TCP for connection and messaging. The PLC makes a TCP connection to the Gocator on port 502. Control and data messages are communicated on this TCP connection. Up to four clients can be connected to the Gocator simultaneously. A connection will be closed after 10 minutes of inactivity.

Messages

All Modbus TCP messages consist of a MBAP header (Modbus Application Protocol), a function code and a data payload.

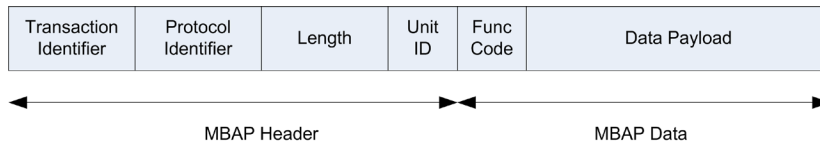

The MBAP header contains the following field:

Modbus Application Protocol Header

Fields	Length (Bytes)	Description
Transaction ID	2	Used for transaction pairing. The Modbus Client sets the value and the Server (Gocator) copies the value into its responses.
Protocol ID	1	Always set to 0.
Length	1	Byte count of the rest of the message, including the Unit identifier and data fields.
Unit ID	1	Used for intra-system routing purpose. The Modbus Client sets the value and the Server (Gocator) copies the value into its responses.

Modbus Application Protocol Specification describes the standard function codes in details. Gocator supports the following function codes:

Modbus Function Code

Function Code	Name	Data Size (bit)	Description
3	Read Holding Registers	16	Read multiple data values from the sensor.
4	Read Input Registers	16	Read multiple data values from the sensor.
6	Write Single Register	16	Send a command or parameter to the sensor.
16	Write Multiple Registers	16	Send a command and parameters to the sensor.

The Data payload contains the registers that can be accessed by Modbus TCP messages. If a message access registers that are invalid, a reply with an exception is returned. Modbus Application Protocol Specification defines the exceptions and describes the data payload format for each function code.

The Gocator data includes 16-bit, 32-bit and 64-bit data. All data are sent in big endian format, with the 32-bit and 64-bit data spread out into two and four consecutive registers.

32-bit Data Format

Register	Name	Bit Position
0	32-bit Word 1	31 .. 16
1	32-bit Word 0	15 .. 0

64-bit Data Format

Register	Name	Bit Position
0	64-bit Word 3	63 .. 48
1	64-bit Word 2	47 .. 32
2	64-bit Word 1	31 .. 16
3	64-bit Word 0	15 .. 0

Registers

Modbus registers are 16-bit wide and are either control registers or output registers.

Control registers are used to control the sensor states(e.g. start, stop or calibrate a sensor), and the output registers report the sensor states, stamps measurement values and decisions. User can read multiple output registers using a single Read Holding Registers or a single Read Input Registers command. Likewise, user can control the state of the sensor using a single Write Multiple Register command.

Control registers are write-only, and output registers are read-only.

Register Map Overview

Register Address	Name	Read/Write	Description
0 - 124	Control Registers	WO	Registers for Modbus commands. Refer to Control Registers (page 166) for detailed descriptions.
300 -371	Sensor States	RO	Report sensor states. Refer to Output Registers (page 167) for detailed descriptions.
900 - 999	Stamps	RO	Return stamps associated with each range data. Refer to Output Registers (page 167) for detailed descriptions.
1000 - 1060	Measurements & Decisions	RO	20 Measurement and decision pairs. Refer to Measurement Registers (page 168) for detailed descriptions.

Control Registers

Control registers are used to operate the sensor. Register 0 stores the command to be executed. Register 1-21 contain parameters for the commands. The Gocator executes a command when the value in Register 0 is changed. To set the parameters before a command is executed, user should setup the parameters and the command using a single Multiple Write register command.

Control Register Map

Register Address	Name	Read/Write	Description
0	Command Register	WO	Command register. Refer to the Command Register Values table below for more information.
1 – 21	Configuration Filename	WO	Null terminated File Name. Specifies the complete filename, including the file extension ".cfg": i.e. "test.cfg" (must be null terminated) Each 16-bit register holds a single character. Only used for Load Configuration Command.

The values used for the Command Register is described below.

Command Register Values

Value	Name	Description
0	Stop running	Stop the sensor. No effect if sensor is already stopped.
1	Start Running	Start the sensor. No effect if sensor is already started.
2	Alignment Calibrate	Start the alignment calibration process. State register 301 will be set to 1 (busy) until the calibration process is complete.
3	Travel Calibrate	Start the travel calibration process. State register 301 will be set to 1 (busy) until the calibration process is complete.

Value	Name	Description
4	Clear Calibration	Clear the calibration.
5	Load Configuration	Activate a configuration file. Registers 1 - 21 specifies the filename.

Output Registers

Output registers are used to output states, stamps and measurements results. Each register address holds a 16-bit data value.

State report the current sensor state.

State Register Map

Register Address	Name	Data Size (bit)	Description
300	Stopped / Running	8	Sensor State: 0 - Stopped 1 - Running
301	Busy	8	Busy State: 0 - Not busy 1 - busy Registers 302-> 363 below are only valid when the Busy State is not busy
302	Calibration State	8	Current Calibration State: 0 - Not calibrated 1- Calibrated
303 – 306	Encoder Value	64	Current Encoder value (ticks).
307 – 310	Time	64	Current time (us).
311 – 371	Live Configuration Name	8 bit for each character	Current Configuration Name. Name of currently loaded config file. does not include the ".cfg" extension. Each 16-bit register contains a single character.

Stamps contain trigger timing information used for synchronizing PLC's actions. PLC can also use this information to match up data from multiple Gocator sensors. Stamps are updated after each range data is processed.

Stamp Register Map

Register Address	Name	Data Size (bit)	Description
979	Inputs	8	Digital input state.
980 – 983	Encoder Index	64	Encoder value when the index is last triggered.
984 – 985	Exposure	32	Exposure (us).
986 – 987	Temperature	32	Sensor temperature (mC).
988 – 991	Encoder Value	64	Encoder value (ticks).
992 – 995	Timestamp	64	Time (us).
996 – 999	Frame Counter	64	Frame counter.

Measurement Registers

Measurement results are reported in pairs of value and decision. Measurement values are 32-bit wide and decisions are 8-bit wide.

The measurement ID defines the register address of each pair. The register address of the first word can be calculated as $(1000 + 3 * ID)$. For example, a measurement with ID set to 4 can be read from registers 1012 (high word), 1013 (low word) and the decision at 1015.

The measurement results are updated after each range data is processed.

Measurement Register Map

Register Address	Name	Data Size (bit)	Description
1000 – 1001	Measurement ID 0 Value	32	Measurement ID 0 Value
1002	Measurement ID 0 Decision	8	Measurement ID 0 Decision
1003 – 1004	Measurement ID 1 Value	32	Measurement ID 1 Value
1005	Measurement ID 1 Decision	8	Measurement ID 1 Decision
...

EtherNet/IP

Ethernet/IP is an industrial protocol that allows bidirectional data transfer with PLCs. It encapsulates the object oriented Common Industrial Protocol (CIP).

This chapter describes the EtherNet/IP messages and data formats. EtherNet/IP communication enables the client to:

- Switch to a different active configuration.
- Calibrate and run sensors.
- Receive sensor states, stamps and measurement results.

EtherNet/IP is enabled in the Output panel. For more information, refer to Ethernet Control and Output (page 83).

Concept

To Ethernet/IP enabled devices on the network, the sensor information is seen as a collection of objects, which have attributes that can be queried. For example, an “assembly object” is a type of object with a data attribute that can be accessed via GetAttribute and SetAttribute commands. The Gocator uses assembly objects to take commands and provide sensor state and measurement values.

The PLC sends a command to start a Gocator. The PLC then periodically queries the attributes of the assembly objects for its latest measurement results. In EtherNet/IP terminology, the PLC is a scanner and the Gocator is an adapter.

The Gocator supports unconnected or connected explicit messaging (with TCP). Implicit I/O messaging is not supported.

The default EtherNet/IP ports are used. Port 44818 is used for TCP connections and UDP queries (e.g. listIdentity requests). Port 2222 for UDP I/O Messaging is not supported

Basic Object

Identity Object (Class 0x01)

Attribute	Name	Type	Value	Description	Access
1	Vendor ID	UINT	1256	ODVA Provided Vendor ID	Get
2	Device Type	UINT	43	Device Type	Get
3	Product Code	UINT	2000	Product Code	Get
4	Revision	USINT USINT	x.x	Byte 0 - Major Revision Byte 1 - Minor Revision	Get
6	Serial number	UDINT	32-bit value	Sensor serial number.	Get
7	Product Name	SHORT STRING 32	"Gocator"	Gocator Product Name	Get

TCP/IP Object (Class 0xF5)

The TCP/IP Object contains read-only network configuration attributes such as IP Address. TCP/IP Configuration via Ethernet/IP is not supported. See Volume 2, Chapter 5-3 of the CIP Specification for a complete listing of TCP/IP object attributes.

Attribute	Name	Type	Value	Description	Access
1	Status	UDINT	0	TCP interface status	Get
2	Configuration Capability	UINT	0		Get
3	Configuration Control	UINT	0	Product Code	Get
4	Physical Link Object	Structure (See description)		See 5.3.3.2.4 of CIP Specification Volume 2: Path size (UINT) Path (Padded EPATH)	Get
5	Interface Configuration	Structure (See description)		See 5.3.3.2.5 of CIP Specification Volume 2" IP Address (UDINT) Network Mask (UDINT), Gateway Address (UDINT) Name Server (UDINT) Secondary Name (UDINT) Domain Name (UDINT)	Get

Ethernet Link Object (Class 0xF6)

The Ethernet Link Object contains read-only attributes such as MAC Address (Attr.3). See Volume 2, Chapter 5-4 of the CIP Specification for a complete listing of Ethernet Link object attributes.

Attribute	Name	Type	Value	Description	Access
1	Interface Speed	UDINT	1000g	Ethernet interface data rate (mbps)	Get
2	Interface Flags	UDINT		See 5.4.3.2.1 of CIP Specification Volume 2: Bit 0: Link Status 0 – Inactive 1 - Active Bit 1: Duplex 0 – Half Duplex 1 – Full Duplex	Get
3	Physical Address	Array of 6 USINTs		MAC Address (for example: 00 16 20 00 2E 42)	Get

Assembly Object (Class 0x04)

The Gocator Ethernet/IP object model includes 3 different assembly objects: Command, State and Sample.

All assembly object instances are static. Data in a data byte array in an assembly object are stored in the Big Endian format.

Command Object

The command object is used to start, stop, calibrate and switch configuration on the sensor.

Command Assembly

Information	Value
Class	0x4
Instance	0x310
Number of Attributes	3
Length	32 bytes
Supported Service	0x10 (Write Single Attribute)

Attributes 1 and 2 are not implemented. These are not required for static assembly object.

Attribute 3

Attribute	Name	Type	Value	Description	Access
3	Command	Byte Array	See Below	Commands parameters Byte 0 - Command. See table below for specification of the values. Byte 1-31 - Used for load configuration command	Get, Set

Command Definitions

Value	Name	Description
0	Stop running	Stop the sensor. No action if the sensor is already stopped
1	Start Running	Start the sensor. No action if the sensor is already started.
2	Alignment Calibrate	Start the calibration process: Byte 1 of the Sensor State Assembly will be set to 1 (busy) until the calibration process is complete, then back to zero.
3	Travel Calibrate	Start the travel calibration process: Byte 1 of the Sensor State Assembly will be set to 1 (busy) until the calibration process is complete, then back to zero
4	Clear Calibration	Clear the calibration
5	Load Configuration	Load a configuration file. Bytes 1 - 31 for the filename: one ASCII character per byte. File name must be NULL terminated. The extension ".cfg" should be included

Sensor State Assembly Object

The sensor state assembly object contains sensor's states such as the current sensor temperature, frame count and encoder values.

Sensor State Assembly

Information	Value
Class	0x4
Instance	0x320
Number of Attributes	3
Length	100 bytes
Supported Service	0x0E (Get Single Attribute)

Attributes 1 and 2 are not implemented. These are not required for static assembly object.

Attribute 3

Attribute	Name	Type	Value	Description	Access
3	Command	Byte Array		Sensor state information. See below for more details	Get

Sensor State Information

Byte	Name	Description
0	Sensor's state	Sensor state: 0 - Ready 1 - Running
1	Command in progress	Command busy status: 0 - Not busy 1 - Busy performing the last command.
2	Calibration state	Calibration status: 0 - Not calibrated 1 - Calibrated The value is only valid when the command in progress is set to 0..
3-10	Encoder	Current encoder position (64-bit signed integer)
11-18	Time	Current time (64-bit unsigned integer)
19	Current Configuration Filename Length	Number of characters in the current configuration filename. (e.g. 8 for "myconfig"). The length does NOT include the .cfg extension.
20-43	Current Configuration Filename	Name of currently loaded config file, does not include the ".cfg" extension. Each byte contains a single character (valid when byte 1 = 0).
44 - 99	Reserved	Reserved bytes

Sample State Assembly

The sample state object contains measurements and their associated stamp information.

Sample State Assembly

Information	Value
Class	0x4
Instance	0x321
Number of Attributes	3
Length	180 bytes
Supported Service	0x0E (Get Single Attribute)

Attribute 3

Attribute	Name	Type	Value	Description	Access
3	Command	Byte Array		Sample state information. See below for more details	Get

Sample State Information

Byte	Name	Description
0-1	Inputs	Digital input state
2-9	Z Index Position	Encoder position at time of last index pulse (64-bit signed integer)
10-13	Exposure	Laser exposure in us
14-17	Temperature	Sensor temperature in degrees celsius * 1000
18-25	Position	Encoder position 64-bit signed integer)
26-33	Time	Time (64-bit unsigned integer)
34-41	Frame Counter	Frame counter (64-bit unsigned integer)
42 - 79	Reserved	Reserved bytes
80-83	Measurement 0	Measurement ID 0 Value
84	Decision 0	Measurement ID 0 Decision
85-88	Measurement 1	Measurement ID 1 Value
89	Decision 1	Measurement ID 1 Decision
...	...	
175-178	Measurement 19	Measurement ID 19 Value
179	Decision 19	Measurement ID 19 Decision

Measurement results are reported in pairs of value and decision. Measurement values are 32-bit wide and decisions are 8-bit wide.

The measurement ID defines the byte position of each pair within the state information. The position of the first word can be calculated as $(80 + 5 * ID)$. For example, a measurement with ID set to 4 can be read from byte 100 (high word) to 103 (low word) and the decision at 104.

In Range mode, the measurement results are updated after each frame is processed.

ASCII Protocol

This chapter describes the ASCII protocol available over the Ethernet and serial outputs. The protocol communicates using ASCII strings and the output result format from the sensor is user-configurable.

Ethernet Communication

Gocator's Ethernet communication is bidirectional. Measurement results are sent on the Ethernet output in one of two modes: Polling or Asynchronous. The ASCII protocol over Ethernet enables the client to

- Switch to a different active configuration.
- Calibrate, run and trigger sensors.
- Receive sensor states, health indicators, stamps and measurement results

As with the Gocator Protocol there are separate channels for Control, Data and Health messages. The Control channel is used for commands. The Data channel is used to receive and poll for measurement results. The Health channel is used to receive health indicators.

The port number used for each channel is configurable. Each port can accept multiple connections, up to a total of 16 connections for all ports.

Channels can share the same port or operate on individual ports. The default port number is 8190 for all channels. The following port numbers are reserved for Gocator internal use: 80, 843, 2000 - 2100, 2500 - 2600, 3100 - 3250.

Asynchronous and Polling Operation

On the Ethernet output, the Data channel can operate asynchronously or by polling. Under asynchronous operation, measurement results are automatically sent on the Data channel when the sensor is in the running state and results become available. The result is sent on all connected data channels.

Under polling operation, when the sensor receives a Get Result command, it will send the latest measurement results on the same data channel that the request is received.

Serial Communication

Gocator's serial communication is unidirectional (output only). Measurement results are sent on the Serial output in Asynchronous mode. While measurement values and decisions can be transmitted to an RS-485 receiver, configuration and control operations must be performed through the Gocator's web interface or through communications on the Ethernet output.

Refer to Serial Output (page 341) for cable pinout information.

Gocator serial communication uses the following connection settings:

Serial Connection Settings

Parameter	Value
Start Bits	1

Parameter	Value
Stop Bits	1
Parity	None
Data Bits	8
Baud Rate (b/s)	115200
Format	ASCII

Command and Reply Format

Commands are sent from the client to the Gocator. Command strings are not case sensitive. The command format is:

<COMMAND><DELIMITER><PARAMETER><TERMINATION>

If a command has more than one parameter, each parameter is separated by the delimiter. Similarly, the reply has the following format:

<STATUS><DELIMITER><OPTIONAL RESULTS><DELIMITER>

The status can either be "OK" or "ERROR". The optional results can be relevant data for the command if successful, or a text based error message if the operation failed. If there is more than one data item, each item is separated by the delimiter.

The delimiter and termination characters are configured in the Special Character settings.

Special Characters

The ASCII Protocol has three special characters.

Special Characters

Special Character	Explanation
Delimiter	Separates input arguments in commands and replies, or data items in results. Default value is ",".
Terminator	Terminates both commands and result output. Default value is "%r%n".
Invalid	Represents invalid measurement results. Default value is "INVALID"

The values of the special characters are defined in the Special Character settings. In addition to normal ASCII characters, the special characters can also contain the following format values.

Format values for Special Characters

Format Value	Explanation
%t	Tab
%n	New line
%r	Carriage return
%%	Percentage (%) symbol

Standard Result Format

Measurement results can either be sent in the standard format, or in a custom format. In the standard format, the users select in the web interface which measurement values and decisions to send. For each measurement the following message is transmitted:

M t_n , i_n , V v_n , D d₁ CR

Standard Result Format:

Field	Shorthand	Length	Description
MeasurementStart	M	1	Start of measurement frame.
Type	t _n	n	Hexadecimal value that identifies the type of measurement. The measurement type is the same as defined in Data Results (page 276) section.
Id	i _n	n	Decimal value that represents the unique identifier of the measurement.
ValueStart	V	1	Start of measurement value. This field and the following Value field are optional – they will only be present if the measurement value has been selected for transmission.
Value	v _n	n	Measurement value, in decimal. The unit of the value is measurement-specific.
DecisionStart	D	1	Start of measurement decision. This field and the following Decision field are optional – they will only be present if the measurement decision has been selected for transmission.
Decision	d ₁	1	Measurement decision: 0 – Fail 1 – Pass

Custom Result Format

In the custom format, users enter a formatting string with place holders to create a custom message. The default formatting string is "%time, %value[0], %decision[0]".

Result Placeholders:

Format Value	Explanation
%time	Timestamp
%encoder	Encoder position
%frame	Frame number
%value[Measurement ID]	Measurement value of the specified measurement ID
%decision[Measurement ID]	Measurement decision of the specified measurement ID

Control Commands

Optional parameters are shown in *italic*. Placeholder for data is surrounded by brackets (<>). In the examples, the delimiter is set to ','.

Start

The Start command starts the sensor system (enters the Running state). This command is only valid when the system is in the Ready state. If a start target is specified, the sensor starts at the target time or encoder (depending on the trigger mode).

Formats

Message	Format
Command	Start, <i>start target</i>
Reply	OK or ERROR, <Error Message>

The start target (optional) is the time or encoder position at which the sensor will be started. The time and encoder target value should be set by adding a delay to the time or encoder position returned by the Stamp command. The delay should be set such that it covers the command response time of the Start command.

Examples:

```
Start
OK
Start,1000000
ok
Start
ERROR, Could not start the sensor
```

Stop

The stop command stops the sensor system (enters the Ready state). This command is valid when the system is in the Ready or Running state.

Formats

Message	Format
Command	Stop
Reply	OK or ERROR, <Error Message>

Examples:

```
Stop
OK
```

Trigger

The trigger command triggers a single frame capture. This command is only valid if the sensor is configured in the Software trigger mode and the sensor is in the Running state. If a start target is specified, the sensor starts at the target time or encoder (depending on the unit setting in the Trigger panel).

Formats

Message	Format
Command	Trigger, <i>start target</i> The start target (optional) is the time or encoder position at which the sensor will be started. The time and encoder target value should be set by adding a delay to the time or encoder position returned by the Stamp command. The delay should be set such that it covers the command response time of the Start command.
Reply	OK or ERROR, <Error Message>

Examples:

```
Trigger
OK
Trigger,1000000
OK
```

Load Configuration

The Load Configuration command switches the active sensor configuration.

Formats

Message	Format
Command	LoadConfig, <i>configuration file name</i> If the configuration file name is not specified, the command returns the current configuration name. An error message is generated if there is no configuration loaded. ".cfg" is appended if the filename does not have an extension.
Reply	OK or ERROR, <Error Message>

Examples:

```
LoadConfig,test.cfg
OK,test.cfg loaded successfully
LoadConfig
OK,test.cfg
LoadConfig,wrongname.cfg
ERROR, failed to load wrongname.cfg
OK
```

Stamp

The Stamp command retrieves the current time, encoder and/or the last frame count.

Formats

Message	Format
Command	Stamp, <i>time, encoder, frame</i> If no parameters are given, time, encoder and frame will be returned. There could be more than one selection.
Reply	If no arguments are specified OK, time, <time value>, encoder, <encoder position>, frame, <frame count> ERROR, <Error Message> If arguments are specified, only the selected stamps will be returned.

Examples:

```
Stamp
OK,Time, 9226989840, Encoder, 0, Frame 6
Stamp frame
```

OK, 6
OK, test.cfg
LoadConfig, wrongname.cfg

Alignment Calibration

The Alignment Calibration command performs an alignment calibration based on the calibration settings in the sensor's live configuration. A reply to the command is sent when the calibration has completed or failed. The command is timed out if there has been no progress after one minute.

Formats

Message	Format
Command	AlignCalibrate
Reply	OK or ERROR, <Error Message>

Examples:

```
AlignCalibrate  
OK  
AlignCalibrate  
ERROR, ALIGNMENT CALIBRATION FAILED
```

Travel Calibration

The Travel Calibration command performs a travel calibration based on the calibration settings in the sensor's live configuration. A reply to the command is sent when the calibration has completed or failed. The command is timed out if there has been no progress after one minute.

Formats

Message	Format
Command	TravelCalibrate
Reply	OK or ERROR, <Error Message>

Examples:

```
TravelCalibrate  
OK  
TravelCalibrate  
ERROR, TRAVEL CALIBRATION FAILED
```

Clear Calibration

The Clear Calibration command clears the calibration record generated by alignment or travel calibration.

Formats

Message	Format
Command	ClearCalibration
Reply	OK or ERROR, <Error Message>

Examples:

```
ClearCalibration  
OK
```

Data Commands

Optional parameters are shown in *italic*. Placeholder for data is surrounded by brackets (<>). In the examples, the delimiter is set to ','.

Get Result

The Get Result command retrieves measurement values and decisions.

Formats

Message	Format
Command	Result, <i>measurement ID</i> , <i>measurement ID</i> ...
Reply	If no arguments are specified, the custom format data string is used. OK, <custom data string> ERROR, <Error Message> If arguments are specified, OK, <data string in standard format> ERROR, <Error Message>

Examples:

Standard data string for measurements ID 0 and 1:

```
Result,0,1  
OK,M00,00,V151290,D0,M01,01,V18520,D0
```

Standard formatted measurement data with a non-existent measurement of ID 2:

```
Result,2  
ERROR,Specified measurement ID not found. Please verify your input
```

Custom formatted data string (%time, %value[0], %decision[0]):

```
Result  
OK,1420266101, 151290, 0
```

Get Value

The Get Value command retrieves measurement values.

Formats

Message	Format
Command	Value, <i>measurement ID</i> , <i>measurement ID</i> ...
Reply	If no arguments are specified, the custom format data string is used. OK, <custom data string> ERROR, <Error Message> If arguments are specified, OK, <data string in standard format, except that the decisions are not sent> ERROR, <Error Message>

Examples:

Standard data string for measurements ID 0 and 1:

```
Value,0,1  
OK,M00,00,V151290,M01,01,V18520
```

Standard formatted measurement data with a non-existent measurement of ID 2:

```
Value,2  
ERROR,Specified measurement ID not found. Please verify your input
```

Custom formatted data string (%time, %value[0]):

```
Value  
OK, 1420266101, 151290
```

Get Decision

The Get Decision command retrieves measurement decisions.

Formats

Message	Format
Command	Decision, <i>measurement ID</i> , <i>measurement ID</i> ..
Reply	If no arguments are specified, the custom format data string is used. OK, <custom data string> ERROR, <Error Message> If arguments are specified, OK, <data string in standard format, except that the values are not sent> ERROR, <Error Message>

Examples:

Standard data string for measurements ID 0 and 1:

```
Decision,0,1  
OK,M00,00,D0,M01,01,D0
```

Standard formatted measurement data with a non-existent measurement of ID 2:

```
Decision,2  
ERROR,Specified measurement ID not found. Please verify your input
```

Custom formatted data string (%time, %decision[0]):

```
Decision  
OK,1420266101, 0
```

Health Commands

Optional parameters are shown in *italic*. Placeholder for data is surrounded by brackets (<>). In the examples, the delimiter is set to ','.

Get Health

The Get Health command retrieves health indicators. Refer to (page 182) for details on health indicators

Formats

Message	Format
Command	Health, <i>health indicator ID</i> . <i>health indicator instance</i> ... More than one health indicator can be specified. Note that the health indicator instance is optionally attached to the indicator ID with a '.'. If the health indicator instance field is used the delimiter cannot be set to '.'.
Reply	OK, <health indicator of first ID>, <health indicator of second ID> ERROR, <Error Message>

Examples:

```
health,2002,2017
OK,46,1674
Health
ERROR,Insufficient parameters.
```

Selcom Serial Protocol

This chapter describes the Selcom Serial Protocol settings and message formats supported by Gocator sensors.

Data communication is synchronous using two unidirectional (output only) RS-485 serial channels: data (Serial_Out0) and clock (Serial_Out1). Refer to Serial Output (page 235) for cable pinout information.

Connection Settings

Selcom Serial Protocol uses the following connection settings:

Serial Connection Settings

Parameter	Value
Data Bits	16
Baud Rate (b/s)	96000, 512000, 1024000
Format	Binary

Message Format

The data channel is valid on the rising edge of the clock and data is output with the most significant bit first, followed by control bits for a total of 16-bit of information per frame. The time between the start of the camera exposure and the delivery of the corresponding range data is fixed to a deterministic value.

The sensor support can output data in either 12 or 14 bits, illustrated below:

MSB = most significant bit, LSB = least significant bit, C = data valid bit (high = invalid)

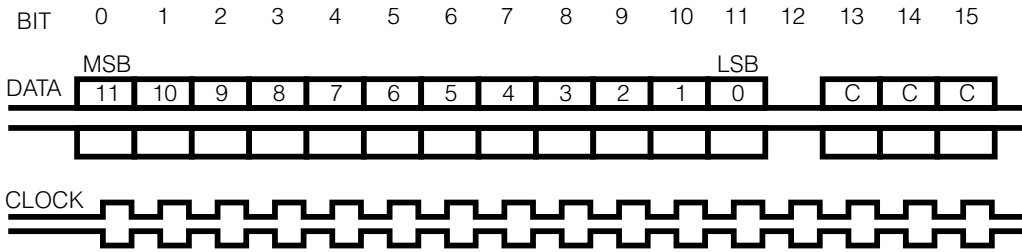

SELCOM SERIAL 12-BIT DATA FORMAT

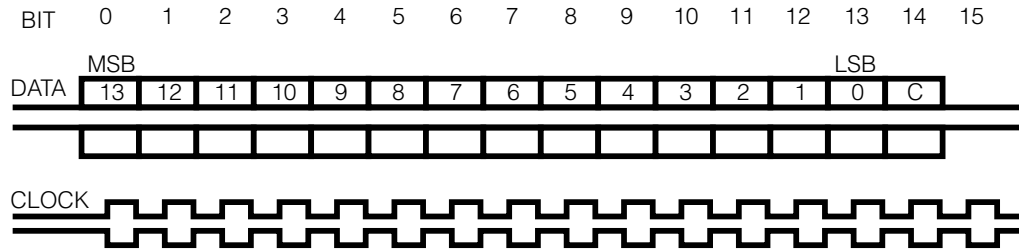

SELCOM SERIAL 14-BIT DATA FORMAT

The results are scaled according to the number of serial bits used to cover the data scale range. Refer to Serial Output (page 92) for information on how to configure the data scale range.

Software Development Kit

The Gocator Software Development Kit (SDK) includes open-source software libraries and documentation that can be used to programmatically access and control Gocator sensors.

The latest version of the SDK can be downloaded from the downloads section, under the support tab, on the LMI Technologies website <http://www.lmi3d.com>.

The following components are included in the SDK.

Component	Description
Gocator API	Gocator API is a C language library that provides support for the commands and data formats used with Gocator sensors.
Gocator Console	Gocator Console is a small console-based application that demonstrates the use of Gocator API.

A pre-built DLL is provided to support 32-bit Windows XP (SP3+) and 32-bit Windows 7. Projects and makefiles are included to support other editions of Windows and Linux.

Example: Configuring and starting a sensor with the Gocator API

```
#include <Go2.h>

void main()
{
    Go2System system = 0;

    //Open the Go2 library.
    Go2Api_Initialize();

    //Construct a Gocator 2000 system object.
    Go2System_Construct(&system);

    //Connect to default sensor IP address, with default password (blank).
    Go2System_Connect(system, GO2_DEFAULT_IP_ADDRESS, GO2_USER_ADMIN, "");

    //Reconfigure system to use time-based triggering.
    Go2System_SetTriggerSource(system, GO2_TRIGGER_SOURCE_TIME);

    //Send the system a "Start" command.
    Go2System_Start(system);

    //Free the system object.
    Go2System_Destroy(system);

    //Close the Go2 library.
    Go2Api_Terminate();
}
```

For more information about programming with the Gocator SDK, refer to the documentation and sample programs included in the Gocator SDK.

Troubleshooting

Review the guidance in this chapter if you are experiencing difficulty with a Gocator sensor system. If the problem that you are experiencing is not described in this chapter, please refer to Warranty and Return Policy (page 249) for further assistance.

Mechanical/Environmental

The sensor is warm.

- It is normal for a sensor to be warm when powered on. A Gocator sensor is typically 15° C warmer than the ambient temperature.

Connection

When attempting to connect to the sensor with a web browser, the sensor is not found (page does not load).

- Verify that the sensor is powered on and connected to the client computer network. The Power Indicator LED should illuminate when the sensor is powered.
- Check that the client computer's network settings are properly configured.
- Ensure that the latest version of Flash is loaded on the client computer.
- Use the LMI Discovery tool to verify that the sensor has the correct network settings. Refer to Recovery (page 113) for more information.

When attempting to log in, the password is not accepted.

- Refer to Recovery (page 113) for steps to reset the password.

Laser Ranging

When the Start button or the Snapshot button is pressed, the sensor does not emit laser light.

- Ensure that the sticker covering the laser emitter window (normally affixed to new sensors) has been removed.
- The laser safety input signal may not be correctly applied. Refer to Specification (page 189) for more information.
- The exposure setting may be too low. Refer to Exposure (page 58) for more information on configuring exposure time.
- Use the Snapshot button instead of the Start button to capture a laser range measurement. If the laser flashes when you use the Snapshot button, but not when you use the Start button, then the problem could be related to triggering. Review the Trigger (page 51) for information on configuring the trigger source.

The sensor emits laser light, but the Range Indicator LED does not illuminate and/or points are not displayed in the Data Viewer.

- Verify that the measurement target is within the sensor's field of view and measurement range. Refer to Specification (page 189) to review the measurement specifications for your sensor model.
- Check that the exposure time is set to a reasonable level. Refer to Exposure (page 58) for more information on configuring exposure time.

Performance

The sensor CPU level is near 100%.

- Consider reducing the speed. If you are using a time or encoder trigger source, refer to Trigger (page 51) for information on reducing the speed. If you are using an external input or software trigger, consider reducing the rate at which you apply triggers.
- Review the measurements that you have programmed and eliminate any unnecessary measurements.

Specification

Gocator 1100 Series

The Gocator 1100 series consists of the sensor models defined below.

MODEL	1120	1125	1150	1160	1165	1170	1190
Clearance Distance	40	182	200	238	562	250	500
Measurement Range (MR) (mm)	20	35	200	325	375	400	2000
Linearity Z (+/- % of MR)	0.05	0.05	0.05	0.05	0.05	0.05	0.10
Linearity Z (+/- mm)	0.010	0.018	0.100	0.163	0.19	0.200	2.0
Resolution Z (mm)	0.0004 - 0.0004	0.0005 - 0.0008	0.0015 - 0.0035	0.0015 - 0.0045	0.0035 - 0.0060	0.0025 - 0.0070	0.0250 - 0.0600
Standard Laser Class	2M	2M	2M	2M	3R	3R	3B
Available Laser Classes*	3R	3R, 3B	2M, 3B	2M, 3B	2M, 3B	2M, 3B	N/A
Standard Package Dimensions (mm)	Side Mount 30x120x149	Side Mount 30x120x149	Side Mount 30x120x149	Side Mount 30x120x149	Side Mount 30x120x220	Side Mount 30x120x149	Side Mount 30x120x277
Available Package Dimensions (mm)	Top Mount 49x75x162	Top Mount 49x75x162	Top Mount 49x75x162	Top Mount 49x75x162	Top Mount 49x75x232	Top Mount 49x75x162	Top Mount 49x75x289
Weight (kg)	0.80	0.80	0.80	0.80	1.1	0.80	1.4

ALL 1100 SERIES MODELS

Scan Rate	10kHz
Interface	Gigabit Ethernet
Inputs	Differential Encoder, Laser Safety Enable, Trigger
Outputs	2x Digital Output, RS-485 Serial, Selcom Serial, 1x Analog Output (4 - 20 mA)
Input Voltage (Power)	+24 to +48 VDC (10 Watts); Ripple +/- 10%
Housing	Gasketed Aluminum Enclosure, IP67
Operating Temp.	0 to 50°C
Storage Temp.	-30 to 70°C

Specifications are preliminary, final specifications may vary. Resolution Z based on 128 samples averaging.

Specifications stated reflect standard laser classes, values will vary for other laser classes.

Gocator 1300 Series

The Gocator 1300 series consists of the sensor models defined below.

MODEL	1320	1325	1350	1360	1365	1370	1390
Clearance Distance	40	182	200	238	562	250	500
Measurement Range (MR) (mm)	20	35	200	325	375	400	2000
Linearity Z (% of MR)	0.05	0.05	0.05	0.05	0.05	0.05	0.05
Linearity Z (+/- mm)	0.010	0.018	0.100	0.163	0.19	0.200	1.000
Resolution Z (mm)	0.0004 - 0.0004	0.0005 - 0.0008	0.0015 - 0.0035	0.0015 - 0.0045	0.0035 - 0.0060	0.0025 - 0.0070	0.0250 - 0.0600
Standard Laser Class	3R	3R	3B	3B	3B	3B	3B
Available Laser Classes*	2M, 3B	2M, 3B	2M, 3R	2M, 3R	2M, 3R	2M, 3R	N/A
Standard Package Dimensions (mm)	Side Mount 30x120x149	Side Mount 30x120x149	Side Mount 30x120x149	Side Mount 30x120x149	Side Mount 30x120x220	Side Mount 30x120x149	Side Mount 30x120x277
Available Package Dimensions (mm)	Top Mount 49x75x162	Top Mount 49x75x162	Top Mount 49x75x162	Top Mount 49x75x162	Top Mount 49x75x232	Top Mount 49x75x162	Top Mount 49x75x289
Weight (kg)	0.8	0.8	0.8	0.8	1.1	0.8	1.4

ALL 1300 SERIES MODELS

Scan Rate	32kHz
Interface	Gigabit Ethernet
Inputs	Differential Encoder, Laser Safety Enable, Trigger
Outputs	2x Digital Output, RS-485 Serial, Selcom Serial, 1x Analog Output (4 - 20 mA)
Input Voltage (Power)	+24 to +48 VDC (10 Watts); Ripple +/- 10%
Housing	Gasketed Aluminum Enclosure, IP67
Operating Temp.	0 to 50°C
Storage Temp.	-30 to 70°C

Specifications are preliminary, final specifications may vary. Resolution Z based on 128 samples averaging.

Specifications stated reflect standard laser classes, values will vary for other laser classes.

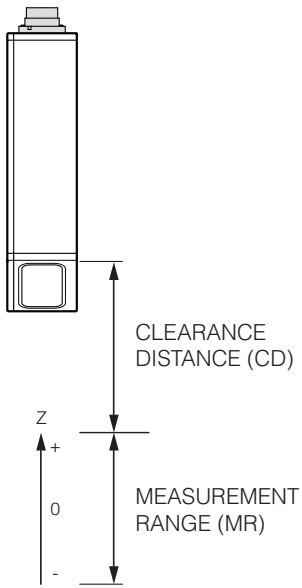

Mechanical dimensions for each sensor model are illustrated on the following pages.

Gocator 1120/1320 (Side Mount Package)

Field of View / Measurement Range

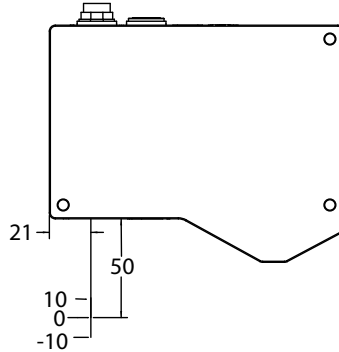

Dimensions

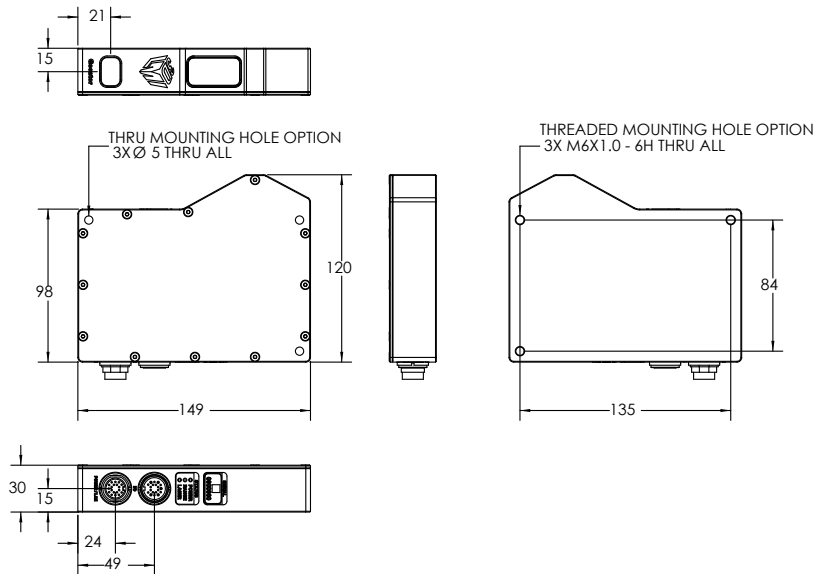

Envelope

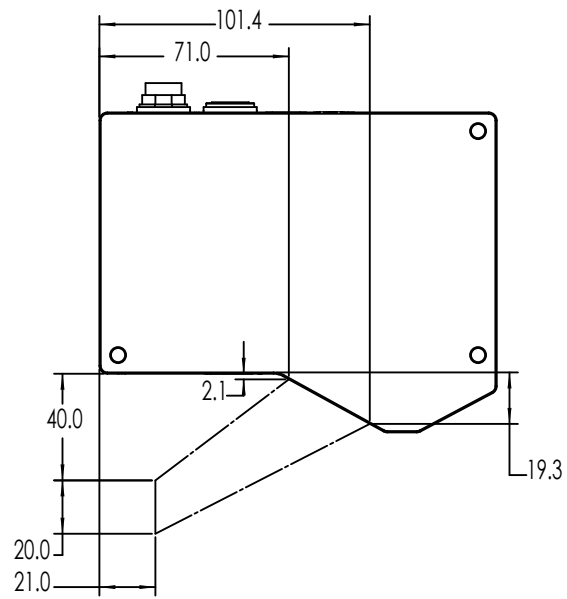

Gocator 1120/1320 (Top Mount Package)

Field of View / Measurement Range

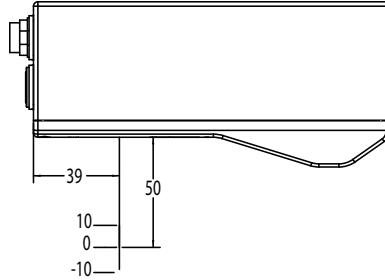

Dimensions

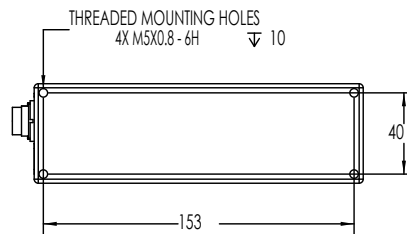
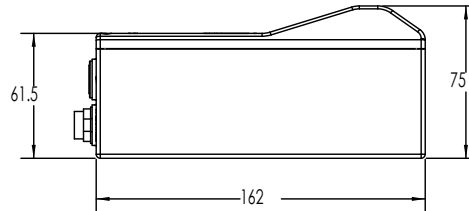
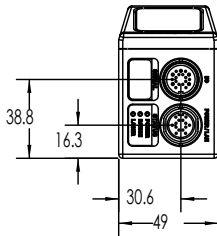
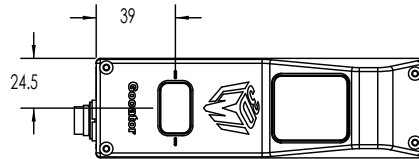

Envelope

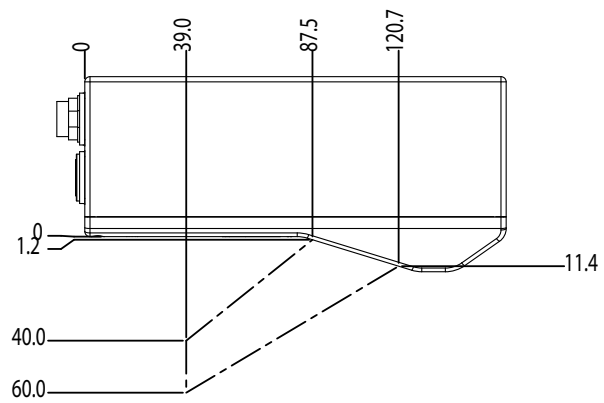

Gocator 1125/1325 (Side Mount Package)

Field of View / Measurement Range

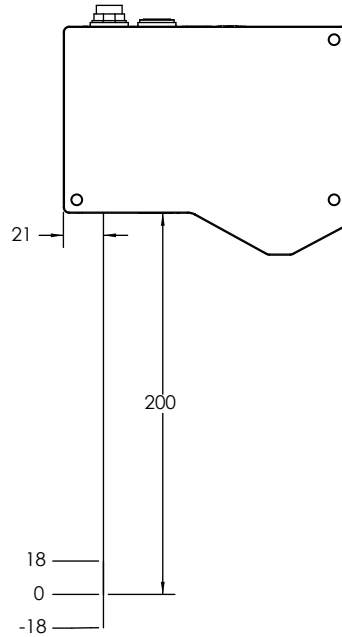

Dimensions

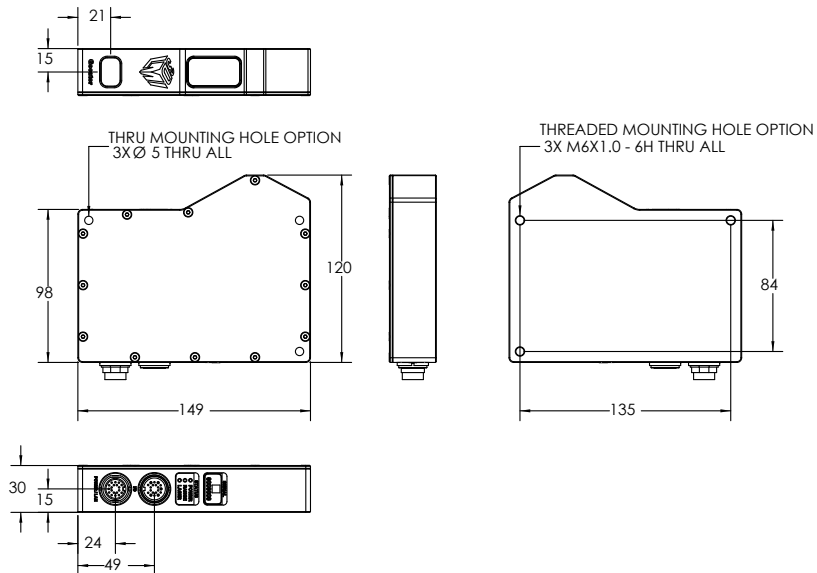

Envelope

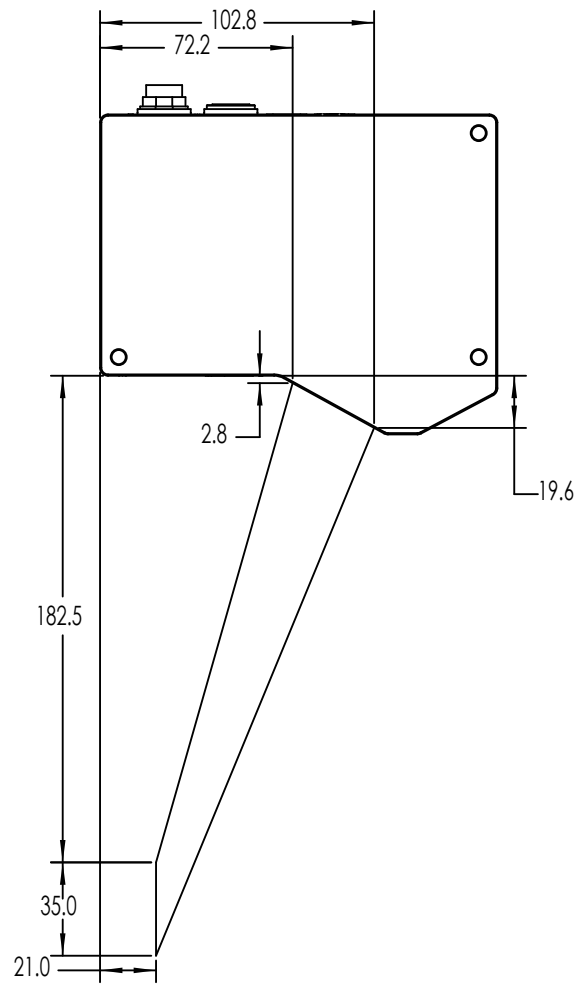

Gocator 1125/1325 (Top Mount Package)

Field of View / Measurement Range

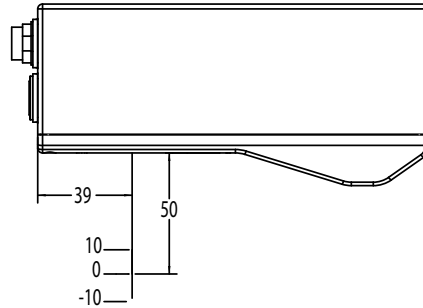

Dimensions

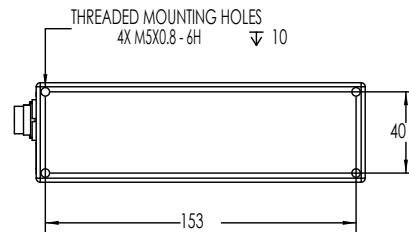
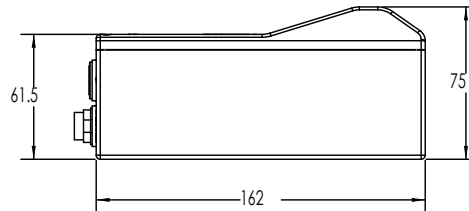
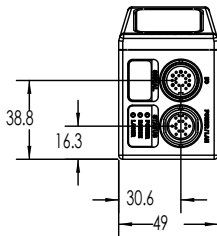
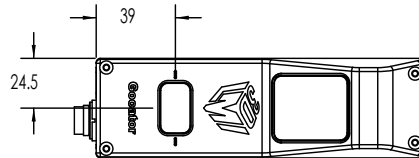

Envelope

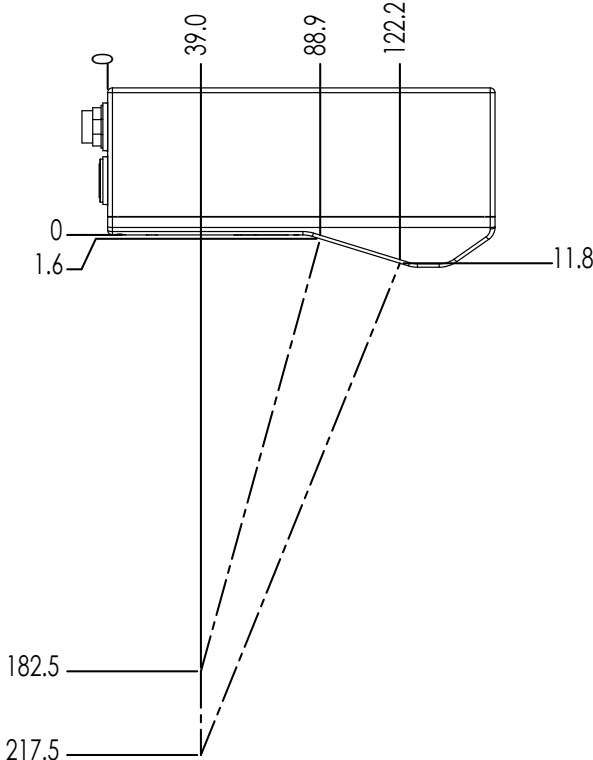

Gocator 1150/1350 (Side Mount Package)

Field of View / Measurement Range

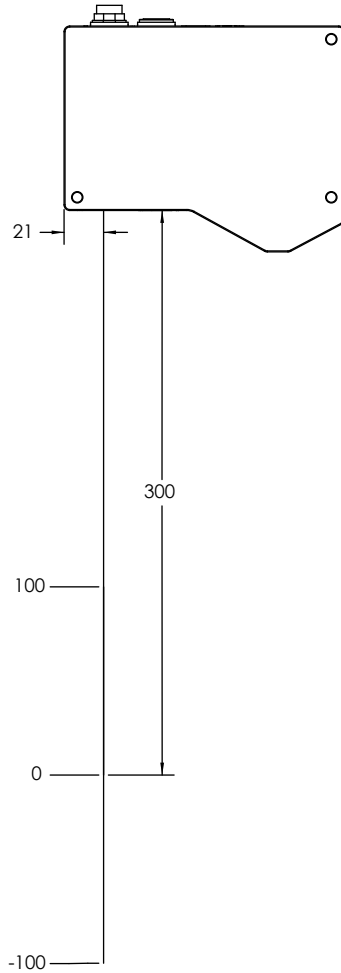

Dimensions

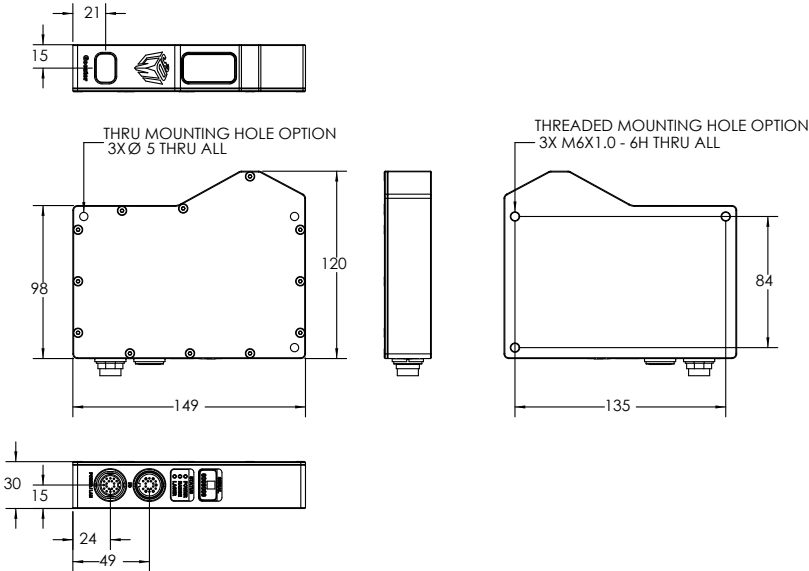

Envelope

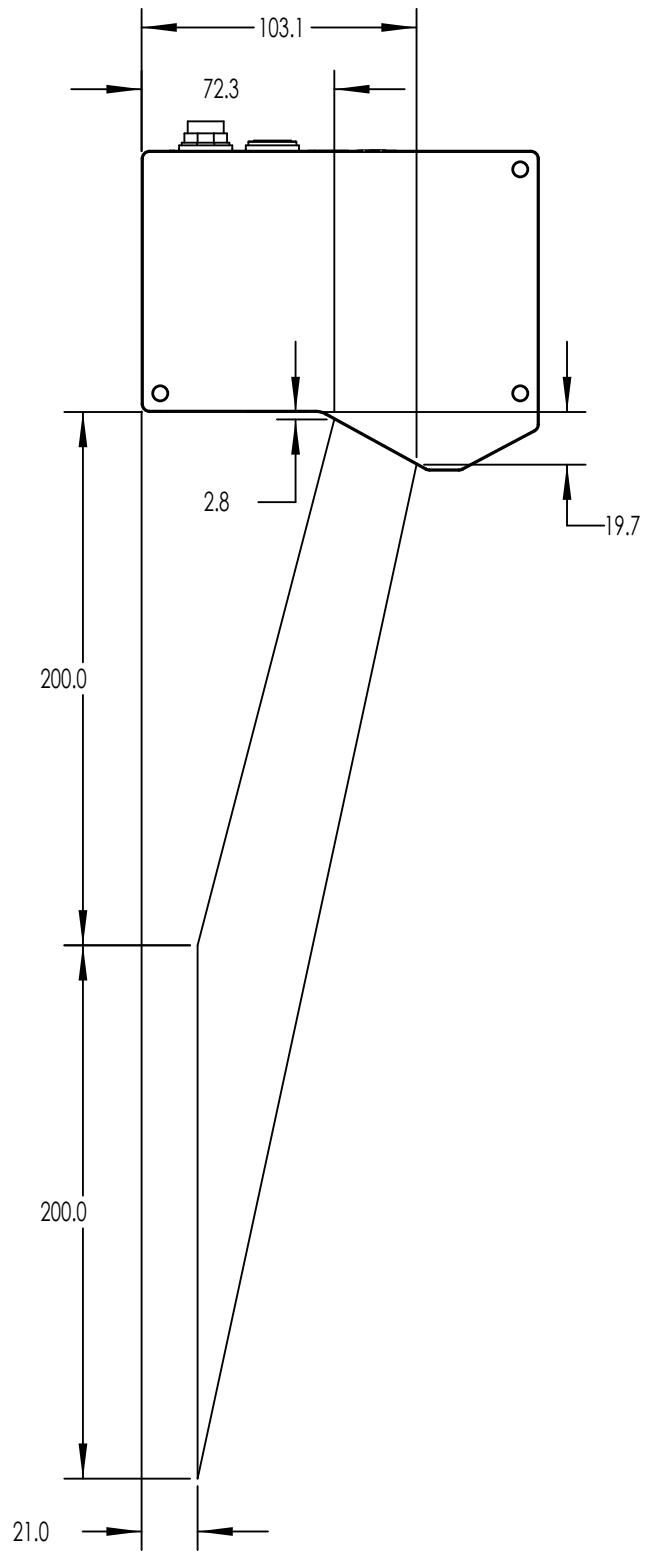

Gocator 1150/1350 (Top Mount Package)

Field of View / Measurement Range

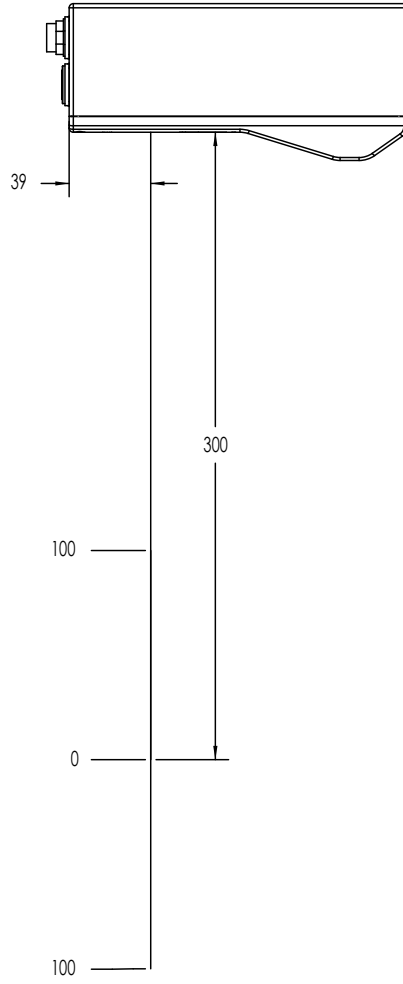

Dimensions

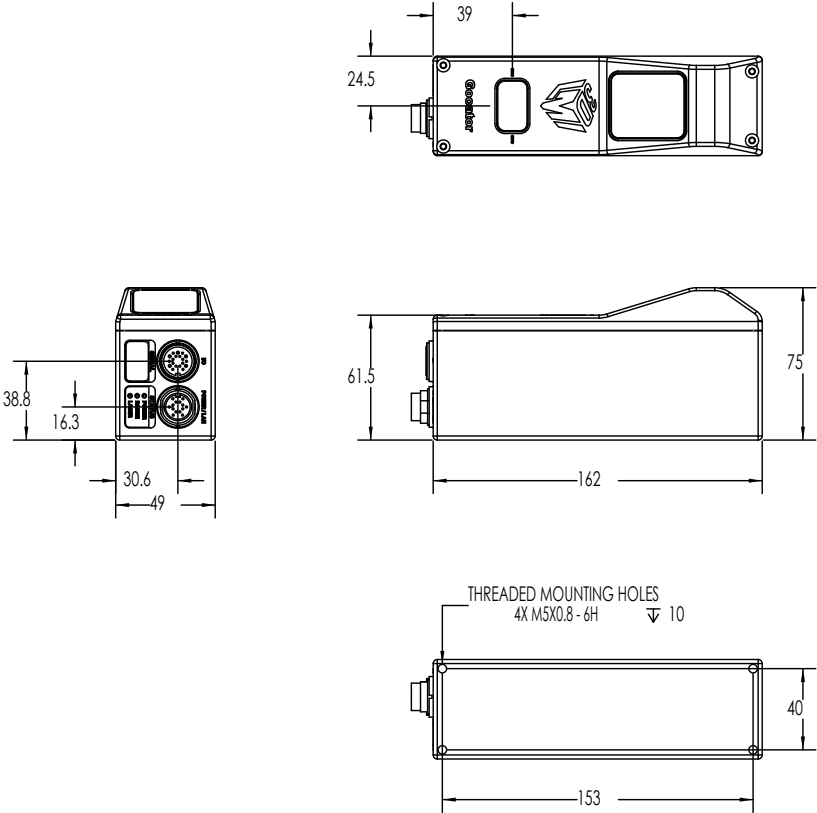

Envelope

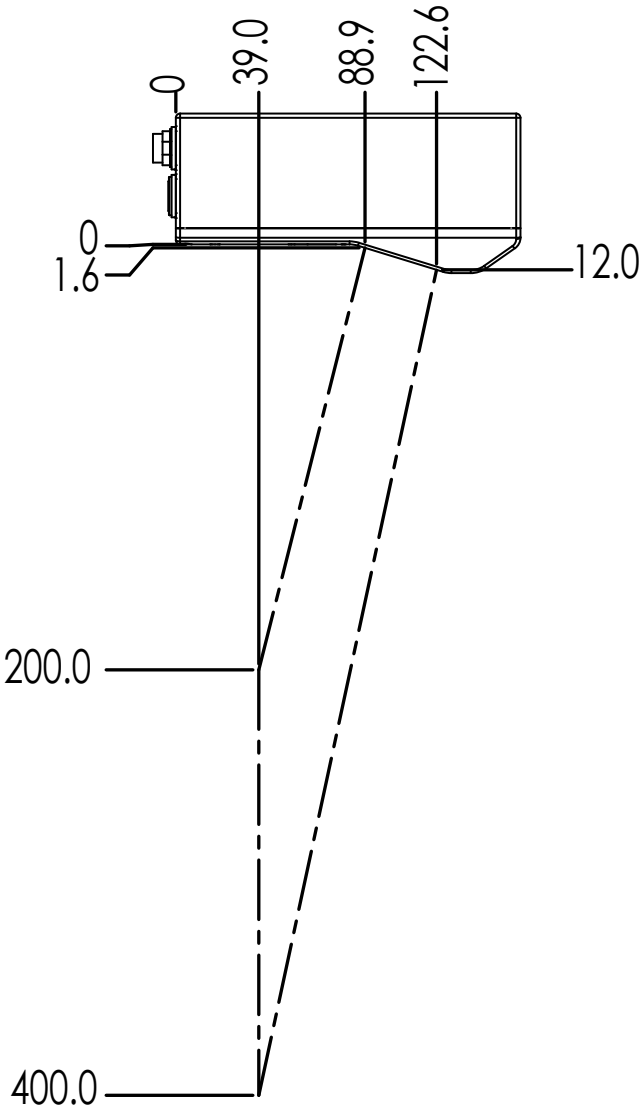

Gocator 1160/1360 (Side Mount Package)

Field of View / Measurement Range

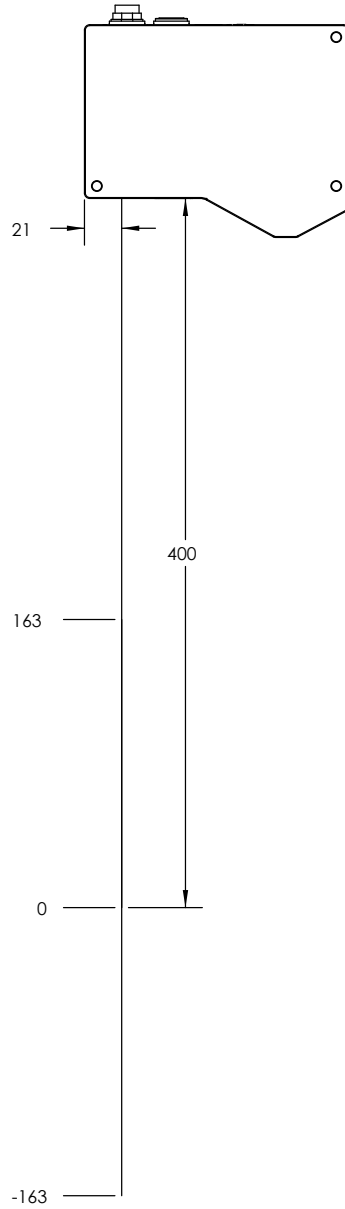

Dimensions

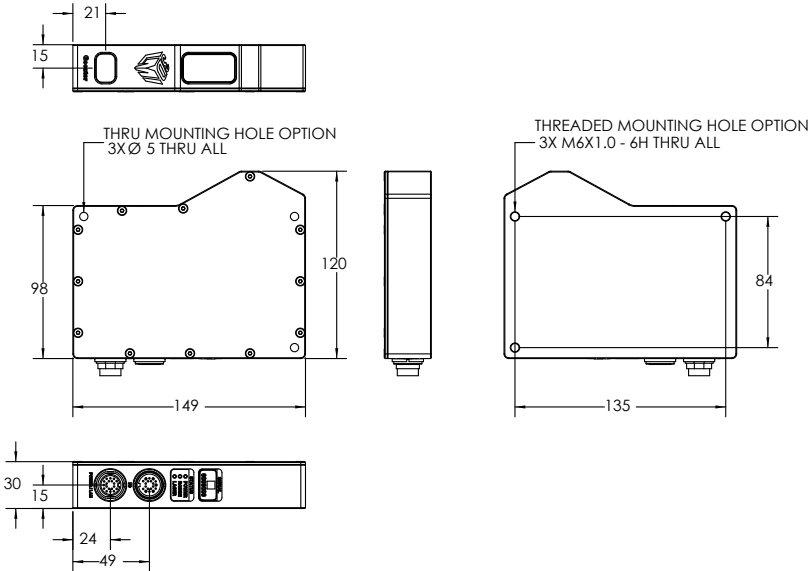

Envelope

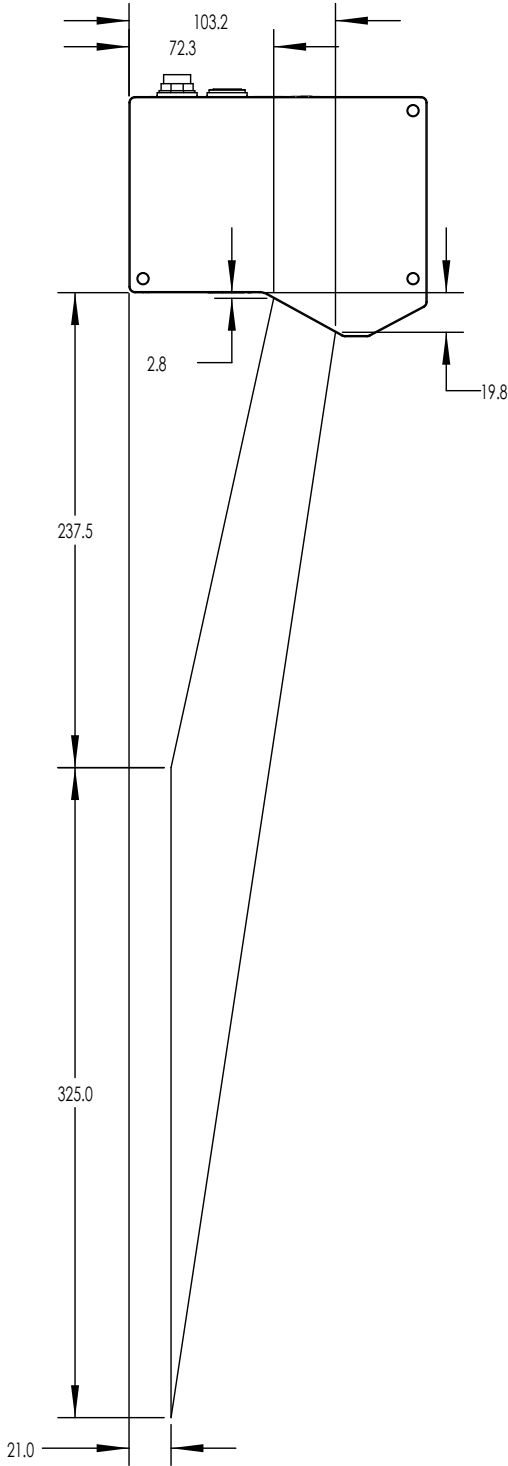

Gocator 1160/1360 (Top Mount Package)

Field of View / Measurement Range

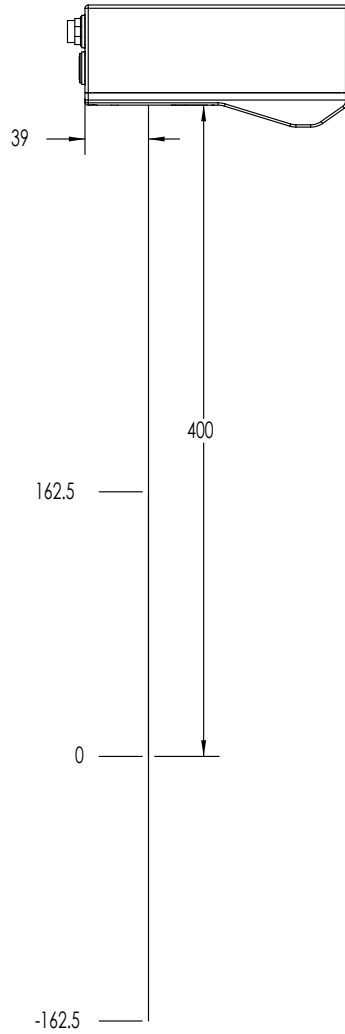

Dimensions

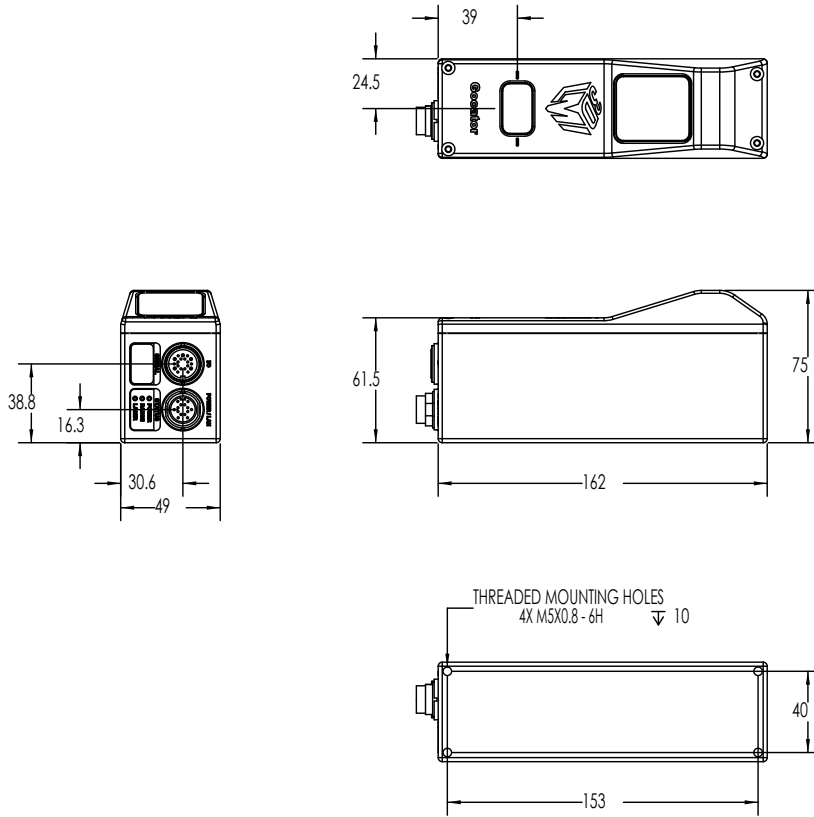

Envelope

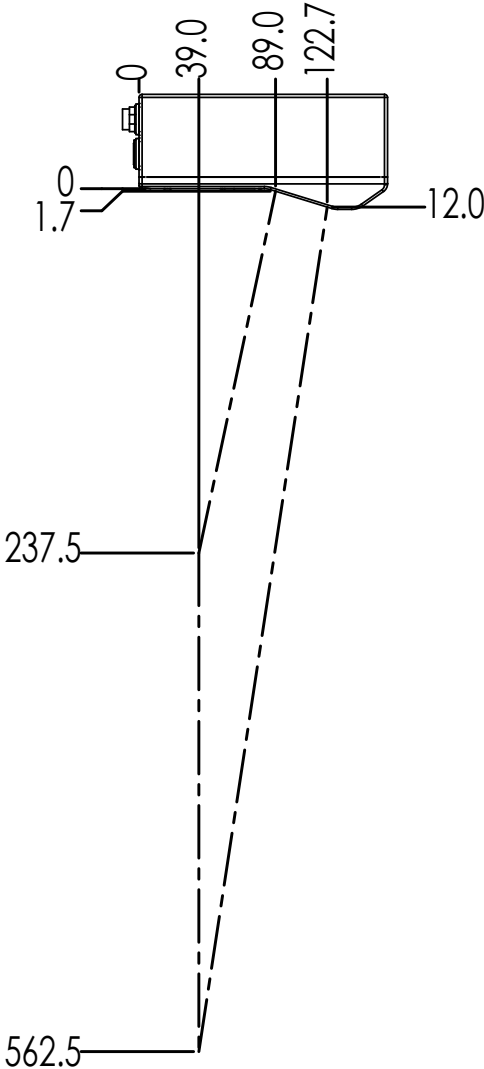

Gocator 1165/1365 (Side Mount Package)

Field of View / Measurement Range

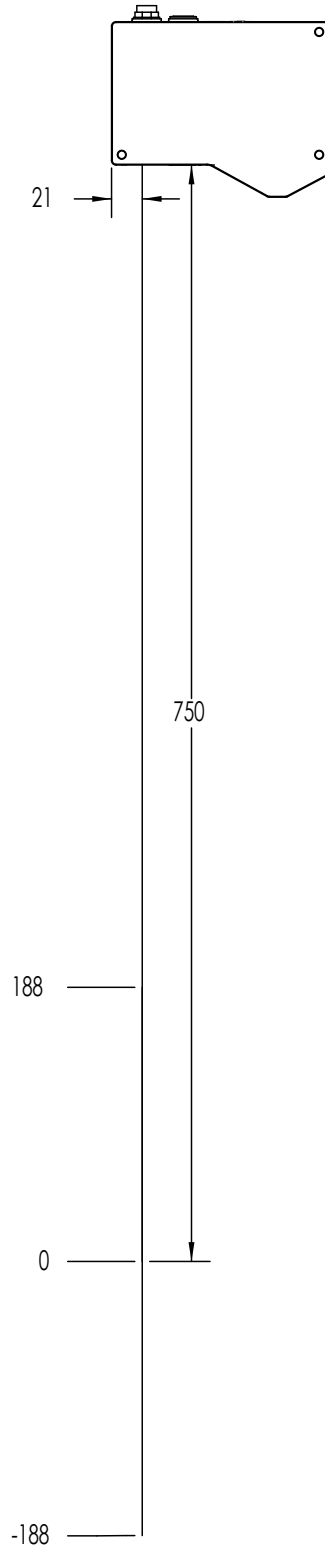

Dimensions

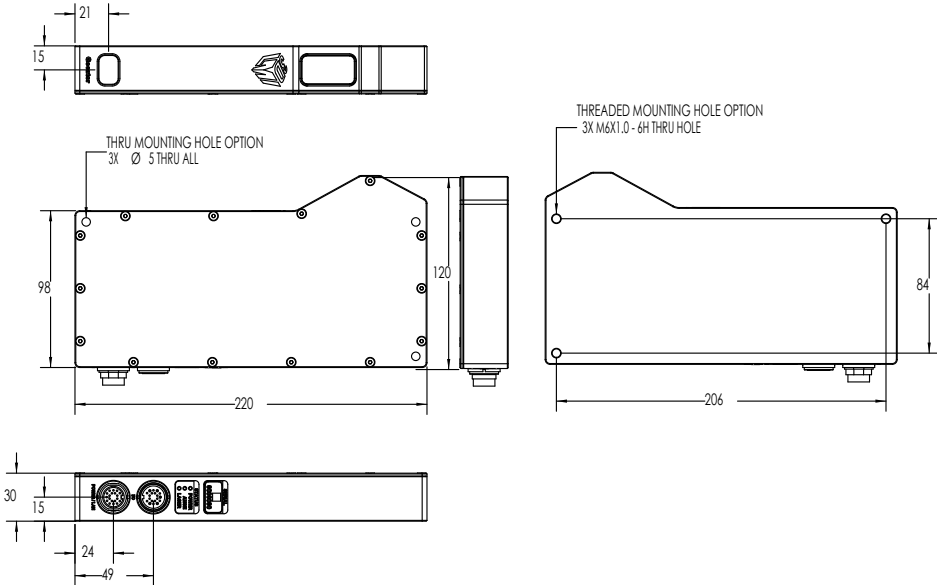

Envelope

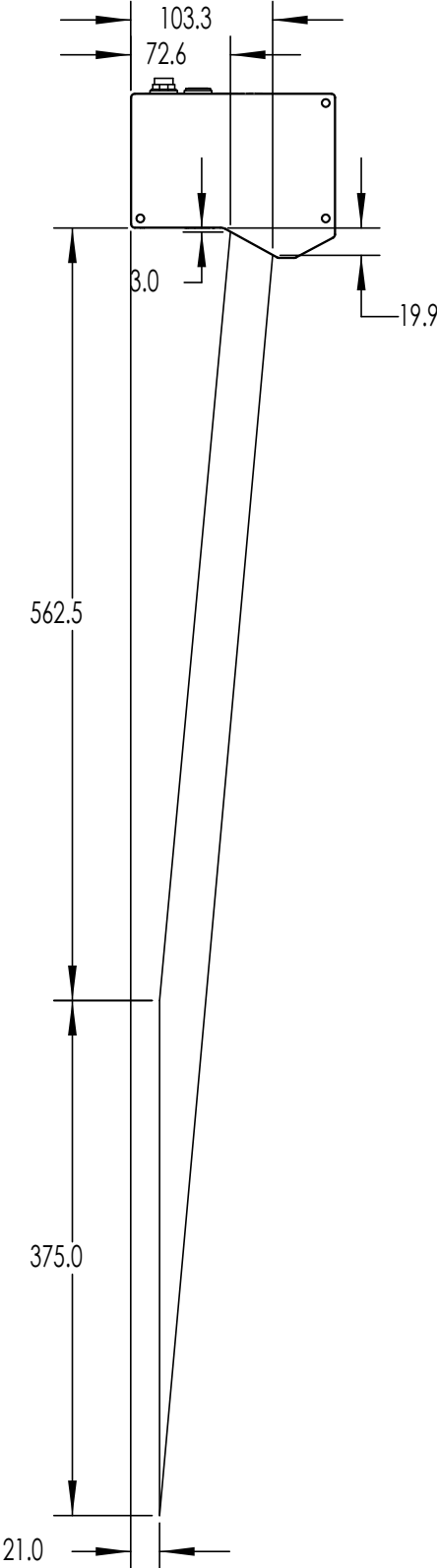

Gocator 1165/1365 (Top Mount Package)

Field of View / Measurement Range

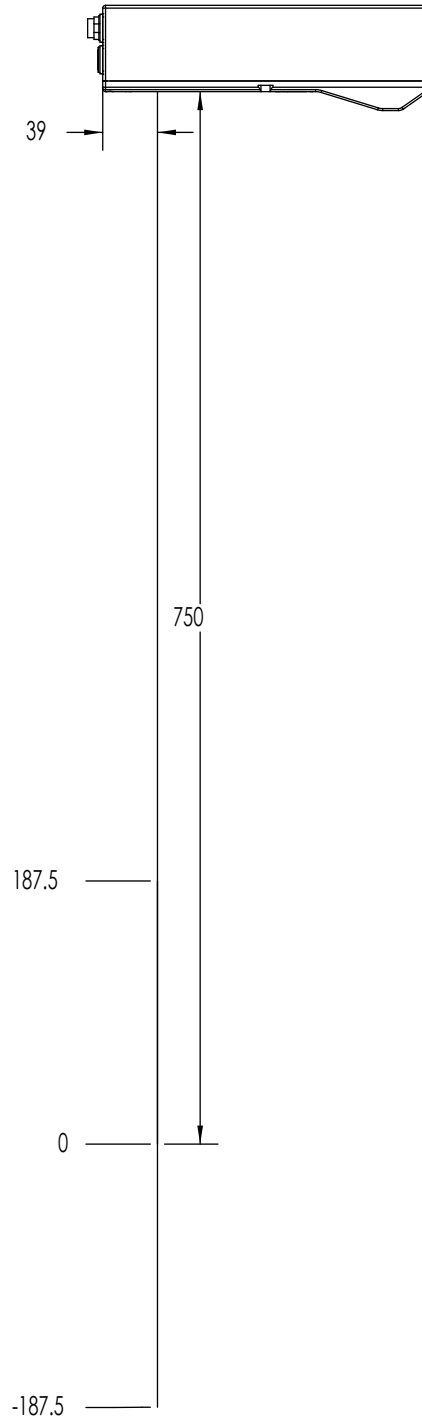

Dimensions

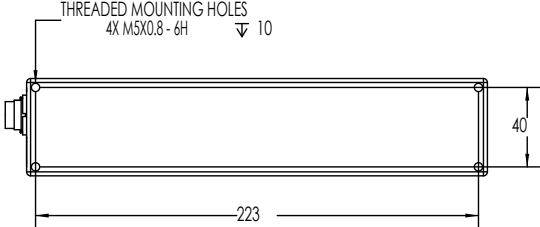
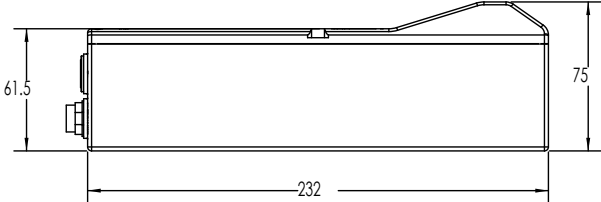
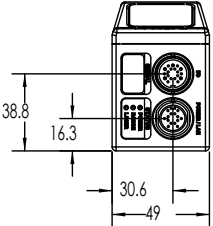
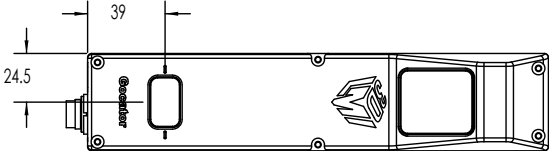

Envelope

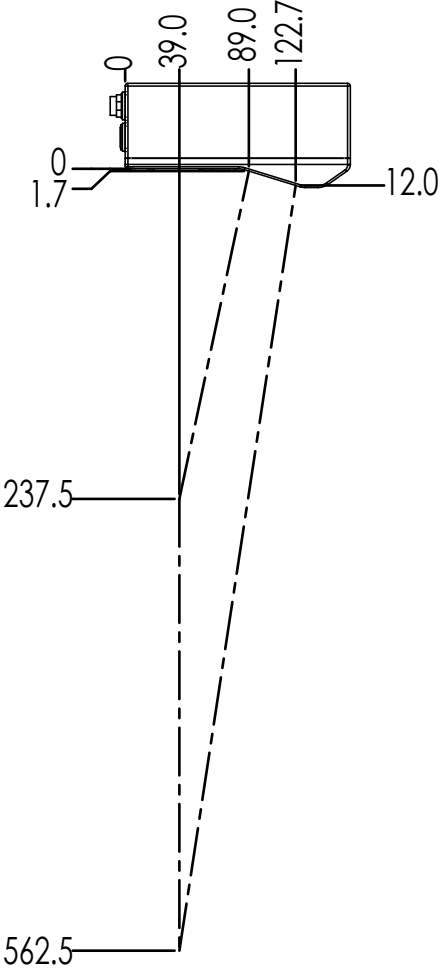

Gocator 1170/1370 (Side Mount Package)

Field of View / Measurement Range

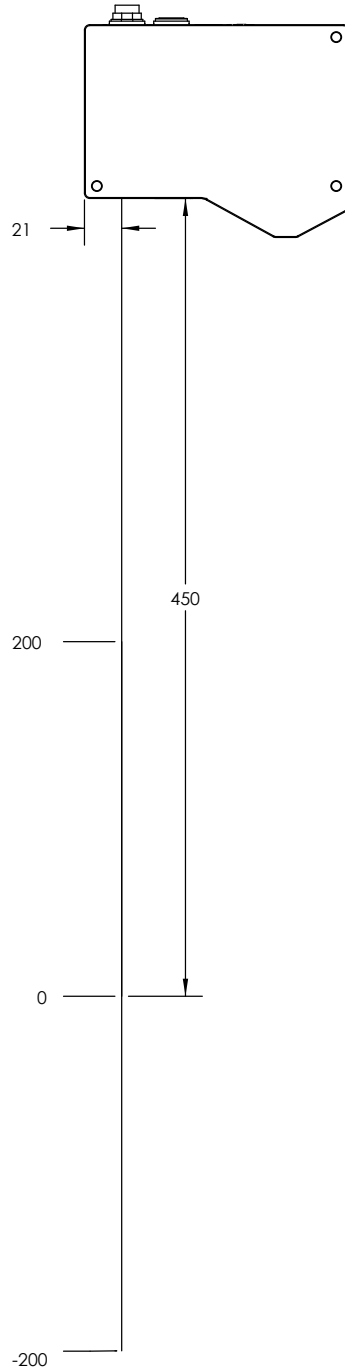

Dimensions

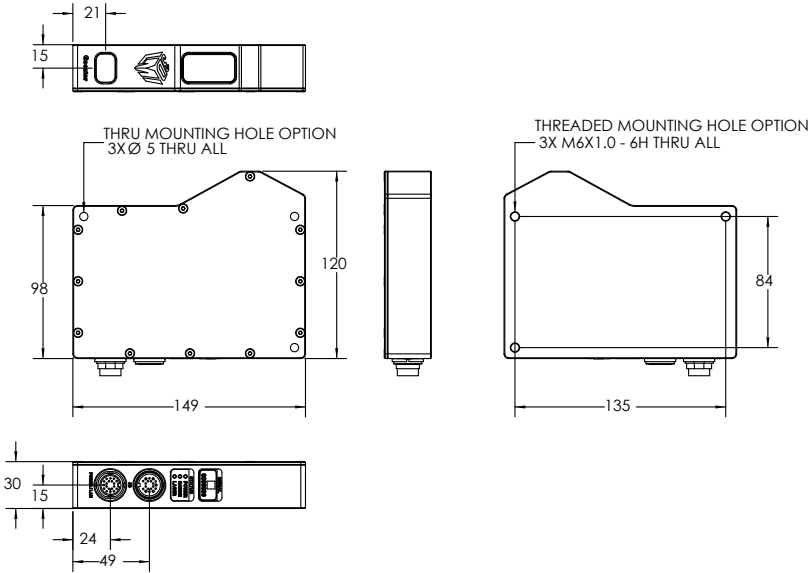

Envelope

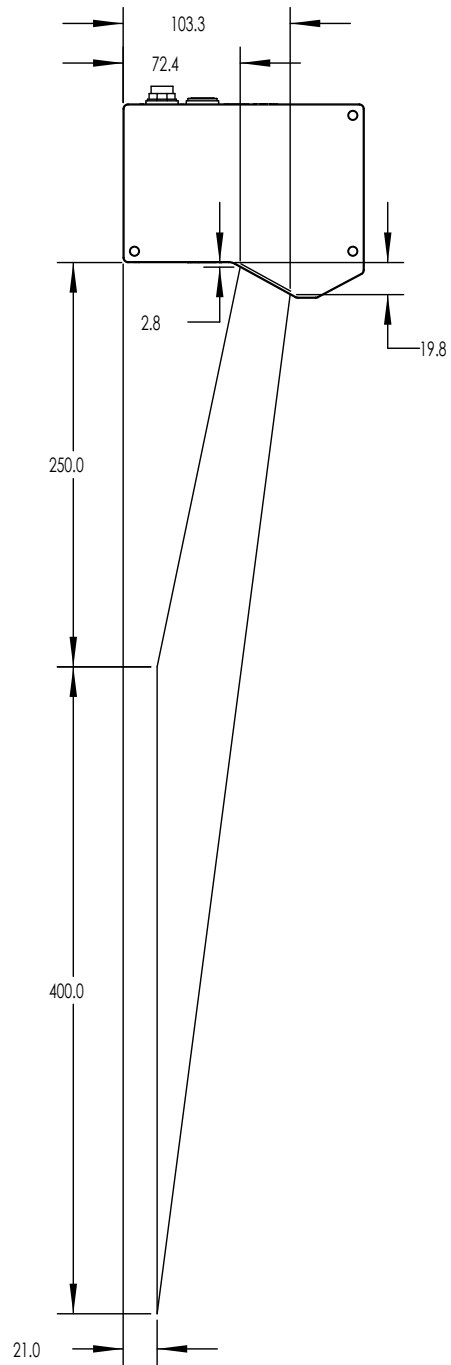

Gocator 1170/1370 (Top Mount Package)

Field of View / Measurement Range

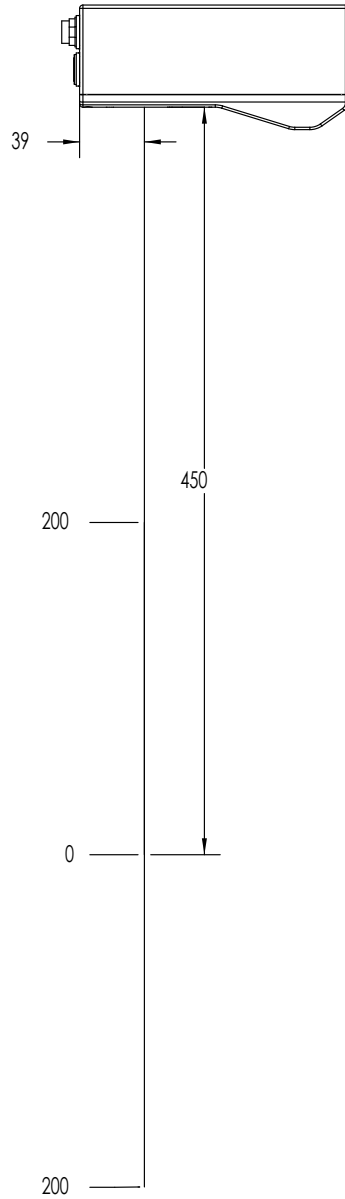

Dimensions

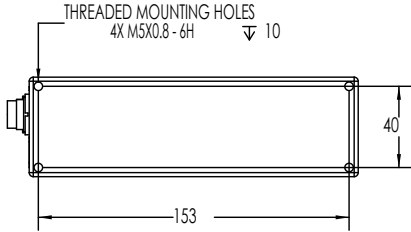
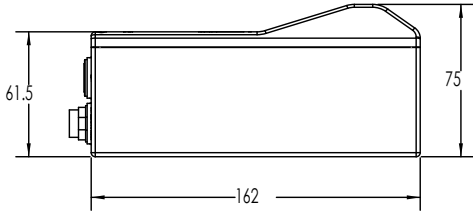
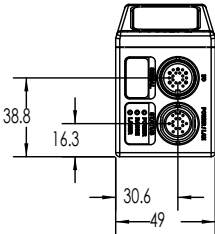
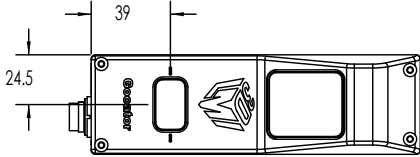

Envelope

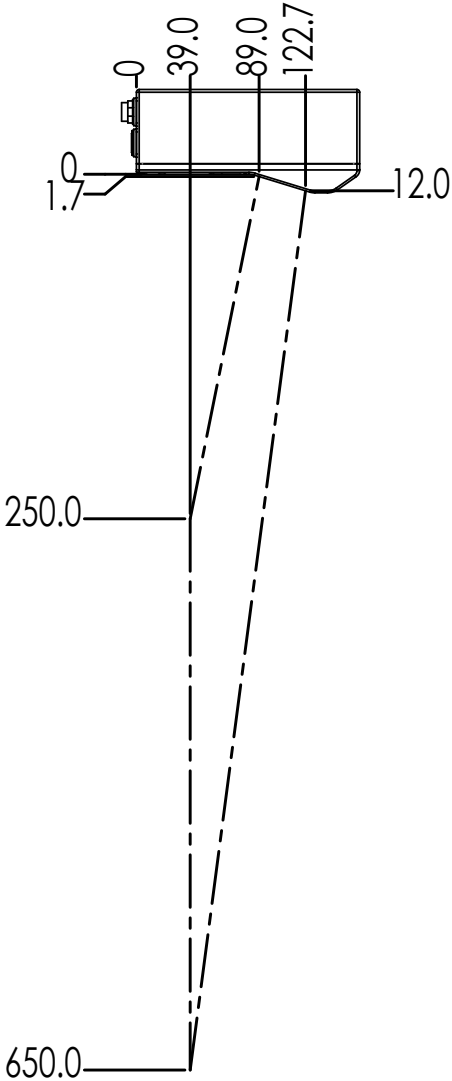

Gocator 1190/1390 (Side Mount Package)

Field of View / Measurement Range

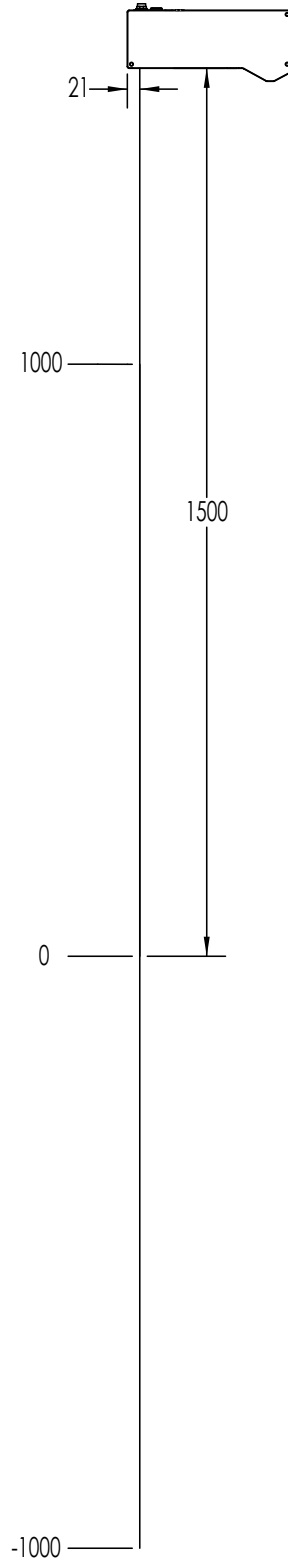

Dimensions

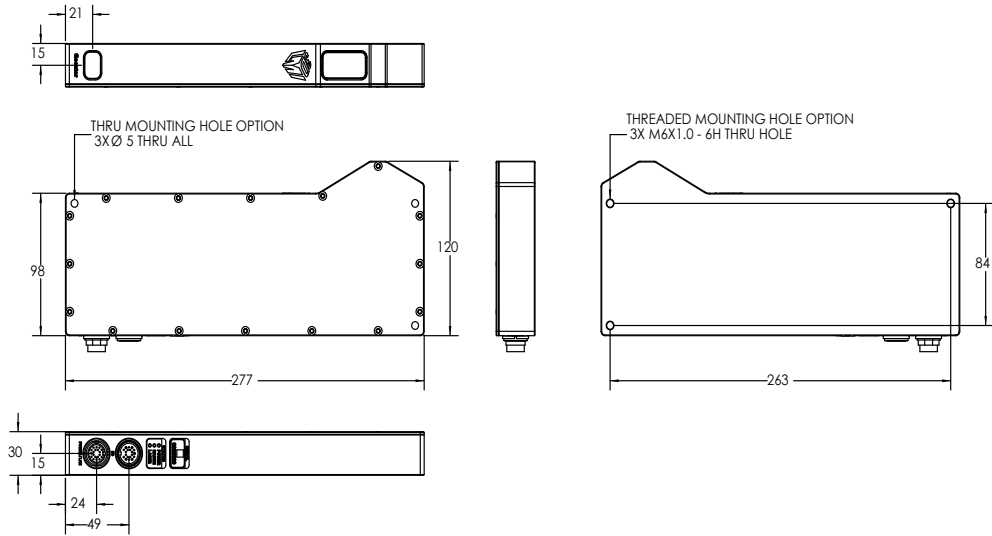

Envelope

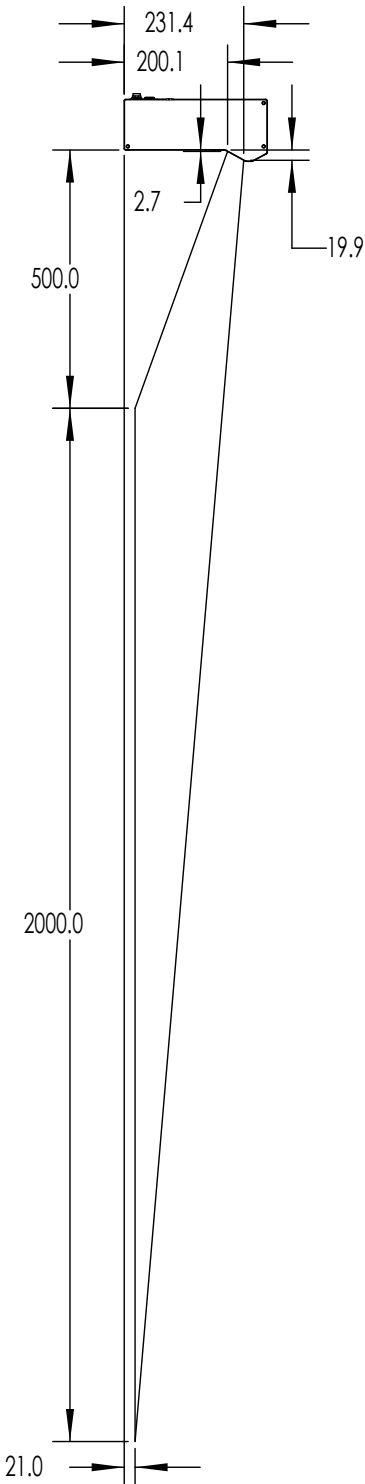

Gocator 1190/1390 (Top Mount Package)

Field of View / Measurement Range

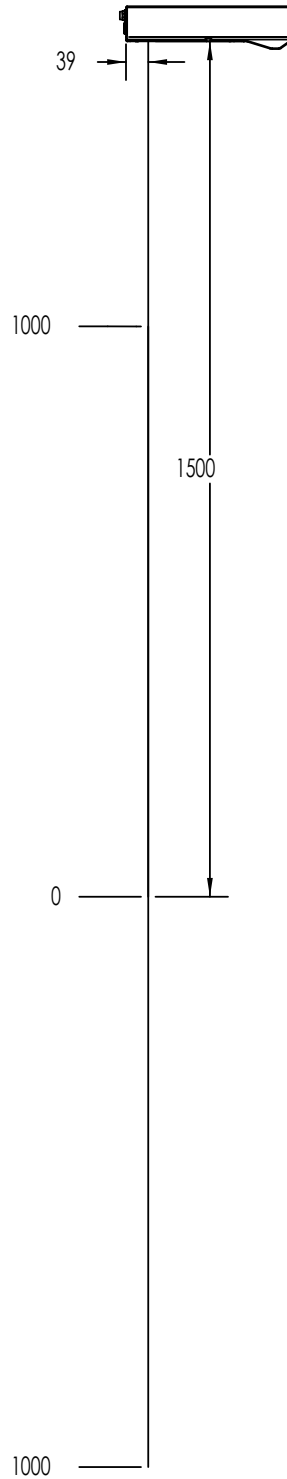

Dimensions

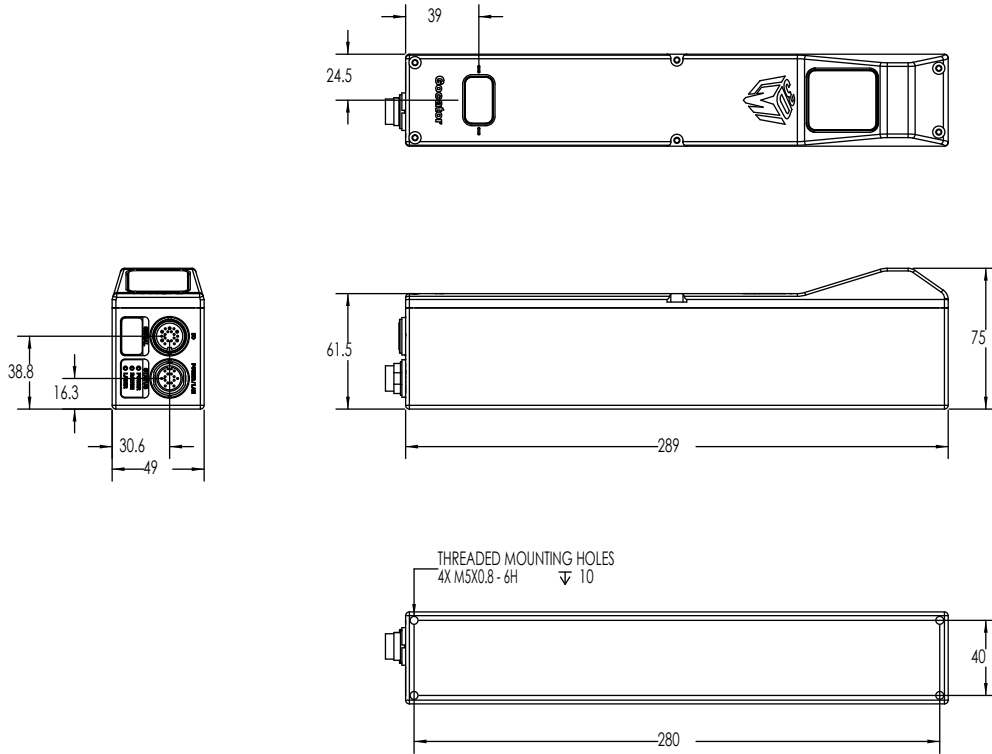

Envelope

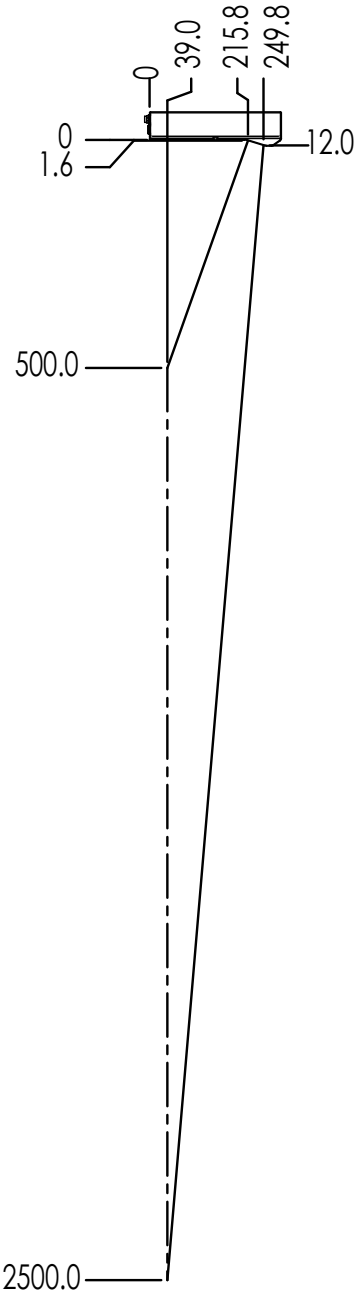

Gocator 1100/1300 Power/LAN Connector

The Gocator 1100 and 1300 Power/LAN connector is a 14 pin, M16 style connector that provides power input, laser safety input and Ethernet.

This section defines the electrical specifications for Gocator Power/LAN Connector pins, organized by function.

Gocator Power Connector Pins

Function	Pin	Color
GND_24-48V	1	White/ Orange & Black
GND_24-48V	1	Orange/ Black
DC_24-48V	2	White/ Green & Black
DC_24-48V	2	Green/ Black
Safety-	3	White/Blue & Black
Safety+	4	Blue/Black
Sync+	5	White/ Brown & Black
Sync-	6	Brown/ Black
Ethernet MX1+	7	White/ Orange
Ethernet MX1-	8	Orange
Ethernet MX2+	9	White/ Green
Ethernet MX2-	10	Green
Ethernet MX3-	11	White/Blue
Ethernet MX3+	12	Blue
Ethernet MX4+	13	White/ Brown
Ethernet MX4-	14	Brown

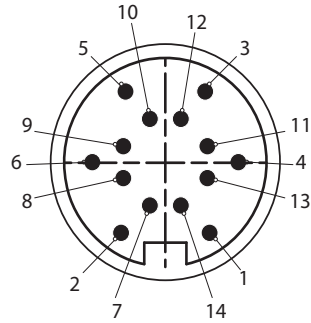

View: Looking into the connector

Two wires are connected to the ground and power pins.

Grounding Shield

The grounding shield should be mounted to the earth ground.

Power

Positive voltage is applied to DC_24-48V @ 10 Watts and Ground is applied to GND_24-48VDC.

Power requirements

Function	Pins	Min	Max
DC_24-48V	2	24 V	48 V
GND_24-48VDC	1	0 V	0 V

Laser Safety Input

The Safety_in+ signal should be connected to a voltage source in the range listed below. The Safety_in- signal should be connected to the ground/common of the source supplying the Safety_in+.

Laser safety requirements

Function	Pins	Min	Max
Safety_in+	4	24 V	48 V
Safety_in-	3	0 V	0 V



Confirm the wiring of Safety_in- before starting the sensor. Wiring DC_24-48V into Safety_in- may damage the sensor

Gocator 1100 and 1300 I/O Connector

The Gocator 1100 and 1300 I/O connector is a 19 pin, M16 style connector that provides encoder, digital input, digital outputs, serial output, and analog output signals.

This section defines the electrical specifications for Gocator I/O Connector pins, organized by function.

Gocator I/O Connector Pins

Function	Pins	Color
Trigger_in+	1	Grey
Trigger_in-	2	Pink
Out_1+ (Digital Output 0)	3	Red
Out_1- (Digital Output 0)	4	Blue
Out_2+ (Digital Output 1)	5	Tan
Out_2- (Digital Output 1)	6	Orange
Encoder_A+	7	White/Brown & Black
Encoder_A-	8	Brown / Black
Encoder_B+	9	Black
Encoder_B-	10	Violet
Encoder_Z+	11	White/Green & Black
Encoder_Z-	12	Green / Black
Serial_out+	13	White
Serial_out-	14	Brown
Serial_out2+	15	Blue / Black
Serial_out2-	16	White / Blue & Black
Analog_out+	17	Green
Analog_out-	18	Yellow & Maroon/White
Reserved	19	Maroon

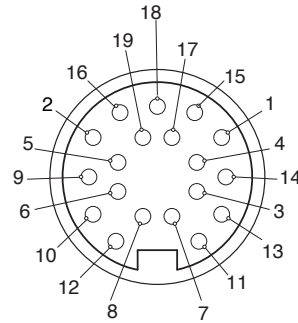

View: Looking into the connector

Grounding Shield

The grounding shield should be mounted to the earth ground.

Digital Outputs

Each Gocator sensor has two optically-isolated outputs. Both outputs are open collector and open emitter, this allows a variety of power sources to be connected and a variety of signal configurations.

Out_1 (Collector – Pin 6 and Emitter – Pin 4) and Out_2 (Collector – Pin 5 and Emitter Pin 8) are independent and therefore V+ and GND are not required to be the same.

Function	Pins	Max Collector Current	Max Collector –Emitter Voltage	Min Pulse Width
Out_1	3, 4	40 mA	70 V	20 us
Out_2	5, 6	40 mA	70 V	20 us

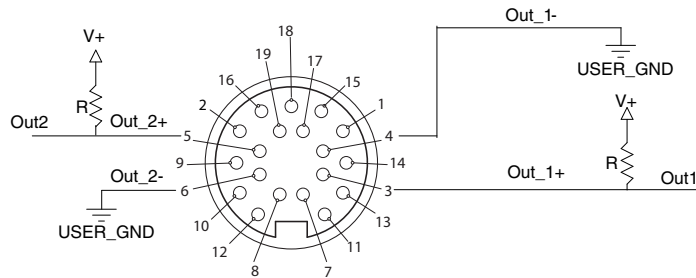

The resistors shown above are calculated by $R = (V+) / 2.5\text{mA}$.
The size of the resistors is determined by power = $(V+)^2 / R$.

Inverting Outputs

To invert an output, connect a resistor between ground and Out_1- or Out_2- and connect Out_1+ or Out_2+ to the supply voltage. Take the output at Out_1- or Out_2-. The resistor selection is the same as what is shown above.

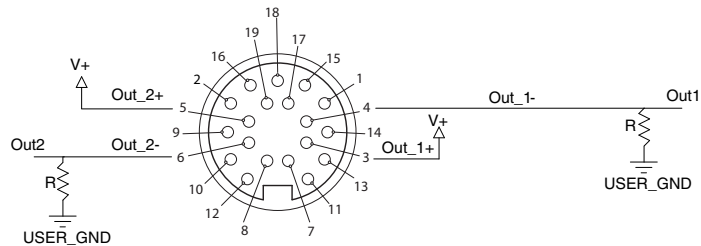

Digital Inputs

Every Gocator sensor has a single optically-isolated input. To use this input without external resistor, supply 3.3 - 12 V to Pin 1 and GND to Pin 2.

Active High

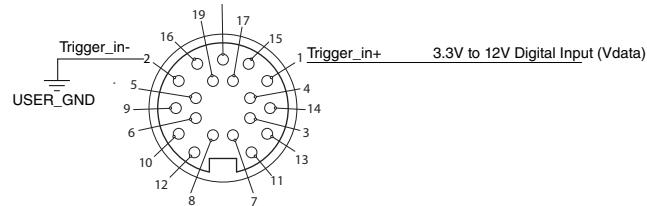

If the supplied voltage is greater than 12 V, connect an external resistor in series to Pin 1. The resistor value should be $R = [(V_{in} - 1.2V) / 10mA] - 680$.

Active Low

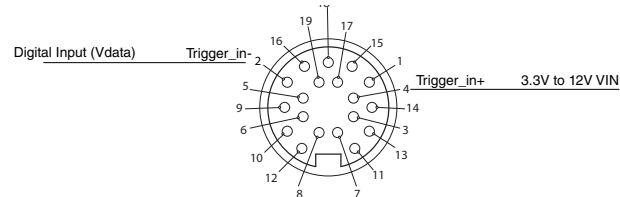

To assert the signal, the digital input voltage should be set to draw a current of 3 mA to 32mA from Trigger_In+. The current that passes through Trigger_In+ is $I = (V_{in} - 1.2 - V_{data}) / 680$. To reduce noise sensitivity, we recommend leaving a 20% margin for current variation (i.e. uses a digital input voltage that draws 4mA to 25mA).

Function	Pins	Min Voltage	Max Voltage	Min Current	Max Current	Min Pulse Width
Trigger_in	1, 2	3.3 V	24V	3 mA	32 mA	20 us

Encoder Input

Encoder input is provided by an external encoder and consists of 3 RS-485 signals. These signals are connected to Encoder_A, Encoder_B and Encoder_Z.

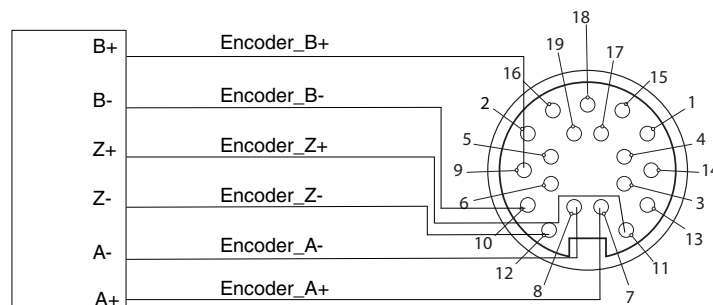

Function	Pins	Common Mode Voltage		Differential Threshold Voltage			Max Data Rate
		Min	Max	Min	Typ	Max	
Encoder_A	7, 8	-7 V	12 V	-200 mV	-125 mV	-50 mV	1 MHz
Encoder_B	9, 10	-7 V	12 V	-200 mV	-125 mV	-50 mV	1 MHz
Ecnoder_Z	11, 12	-7 V	12 V	-200 mV	-125 mV	-50 mV	1 MHz

 Gocator only supports differential RS485 signalling. Both + and - signals must be connected.

Serial Output

Serial RS-485 output is connected to Serial_out as shown below.

Function	Pins
Serial_out	13, 14

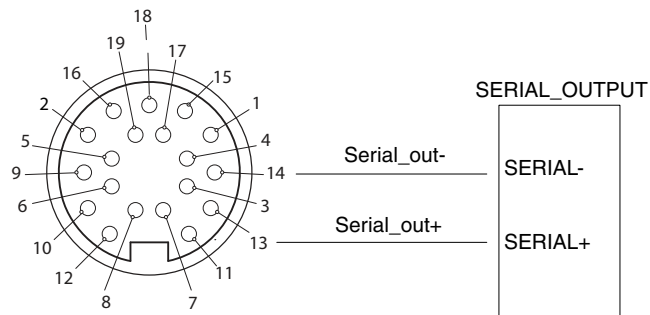

Selcom Serial Output

Serial RS-485 output is connected to Serial_out and Serial_out2 as shown below.

Function	Pins
Serial_out (data)	13, 14
Serial_out2 (clock)	15, 16

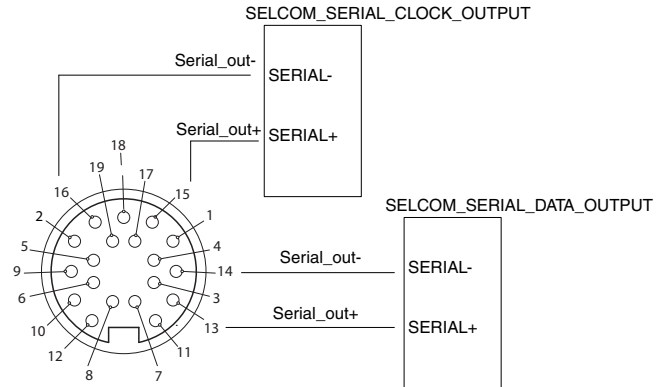

Analog Output

The Sensor I/O Connector defines one analog output interfaces: Analog_out.

Function	Pins	Current Range
Analog_out	17, 18	4 – 20 mA

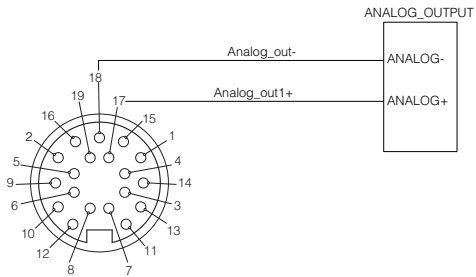

Current Mode

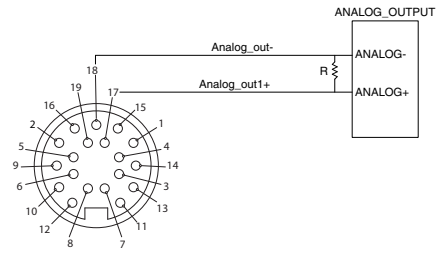

Voltage Mode

To configure for voltage output, connect a 500 Ohm ¼ Watt resistor between Analog_out+ and Analog_out- and measure the voltage across the resistor. To reduce the noise in the output, we recommend using a RC filter as shown below.

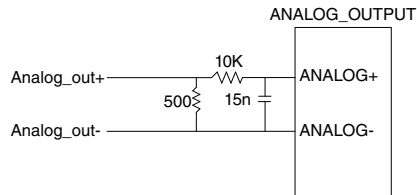

Master 100

The Master 100 accepts connections for power, safety, encoder, and provides digital output.

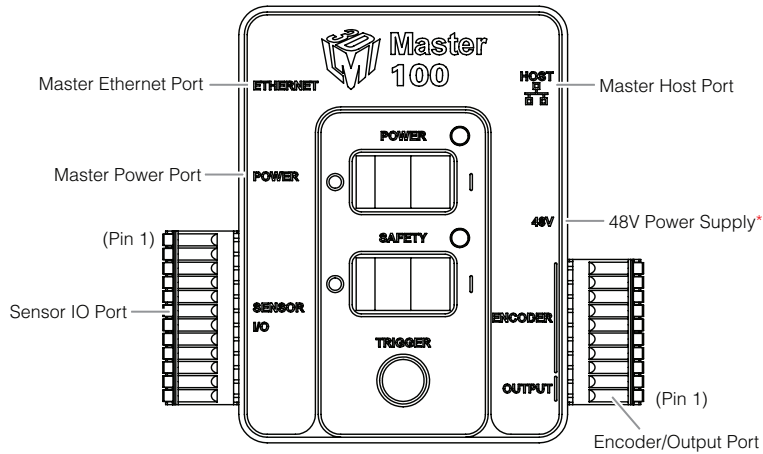

 *Contact LMI for information regarding this type of power supply.

Connect the Master Power port to the Gocator's Power/LAN connector using the Gocator Power/LAN to Master cordset. Connect power RJ45 end of the cordset to the Master Power port. The Ethernet RJ45 end of the cordset can be connected directly to the Ethernet switch, or connect to the Master Ethernet port. If the Master Ethernet port is used, connect the Master Host port to the Ethernet switch with a CAT5E Ethernet cable.

To use encoder and digital output, wire the Master's Gocator Sensor I/O port to the Gocator IO connector using the Gocator I/O cordset.

Sensor I/O Port Pins

Gocator I/O Pin	Master Pin	Conductor Color
Encoder_A+	1	White/Brown & Black
Encoder_A-	2	Brown/Black
Encoder_Z+	3	White/Green & Black
Encoder_Z-	4	Green/Black
Trigger_in+	5	Grey
Trigger_in-	6	Pink
Out_1-	7	Blue
Out_1+	8	Red
Encoder_B+	11	Black
Encoder_B-	12	Violet

The rest of the wires in the Gocator I/O cordset are not used.

Encoder/Output Port Pins

Function	Pin
Output_1+ (Digital Output 0)	1
Output_1- (Digital Output 0)	2
Encoder_Z+	3

Function	Pin
Encoder_Z-	4
Encoder_A+	5
Encoder_A-	6
Encoder_B+	7
Encoder_B-	8
Encoder_GND	9
Encoder_5V	10

Master 100 Dimensions

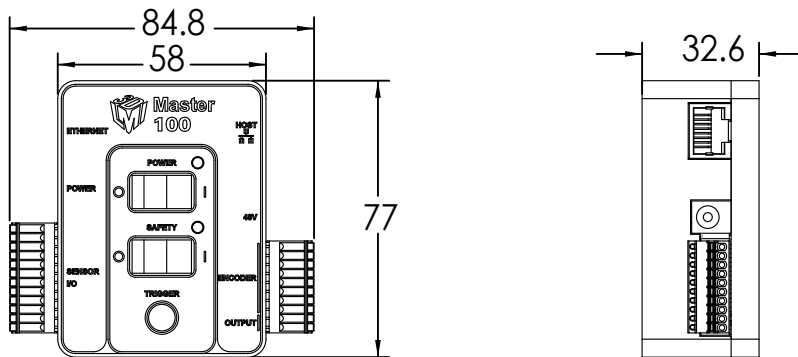

Master 400/800

The Master 400/800 provides sensor power, safety interlock and broadcasts system-wide synchronization information (ie. time, encoder count, encoder index and digital I/O states) to all devices on a sensor network.

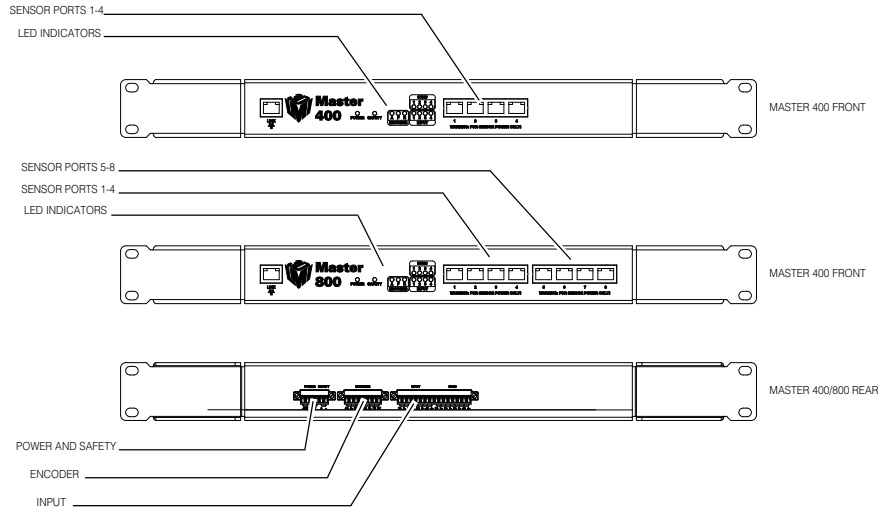

Power and Safety (6 pin connector)

Function	Pin
+48VDC	1
+48VDC	2
GND(48VDC)	3
GND(48VDC)	4
Safety Control+	5
Safety Control-	6

The +48VDC power supply must be isolated from AC ground. This means that AC ground and DC ground are not connected.

The Safety Control requires a voltage differential 12VDC to 48VDC across the pin to enable the laser.

Encoder (8 pin connector)

Function	Pin
Encoder_A+	1
Encoder_A-	2
Encoder_B+	3
Encoder_B-	4
Encoder_Z+	5
Encoder_Z-	6
GND	7
+5VDC	8

Digital Input (16 pin connector)

Function	Pin
Input 1	1
Input 1 GND	2
Reserved	3
Reserved	4
Reserved	5
Reserved	6
Reserved	7
Reserved	8
Reserved	9
Reserved	10
Reserved	11
Reserved	12
Reserved	13
Reserved	14
Reserved	15
Reserved	16

This connector does not need to be wired up for proper operation.

Master 400/800 Electrical Specifications

Electrical specifications for Master 400/800:

	Master 400	800
Power Supply Voltage		+48VDC
Power Supply current (Max.)		10A
Power Draw (Min.)		15W
Safety Voltage		+12 to +48VDC
Encoder signal voltage range		RS485 Differential
Digital input voltage range		Logical LOW: 0 VDC to +0.1VDC Logical HIGH: +11 VDC to +22.5VDC



When using a Master 400/800 it is crucial that its chassis be well grounded.



The +48VDC power supply must be isolated from AC ground. This means that AC ground and DC ground are not connected.



The Power Draw specification is based on a Master with no sensors attached. Every sensor has its own power requirements which need to be considered when calculating total system power requirements.

Master 400/800 Dimensions

Dimensions of Master 400 and Master 800 are the same.

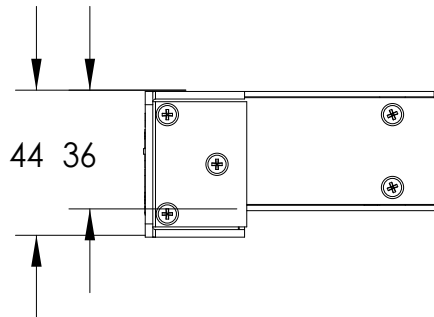
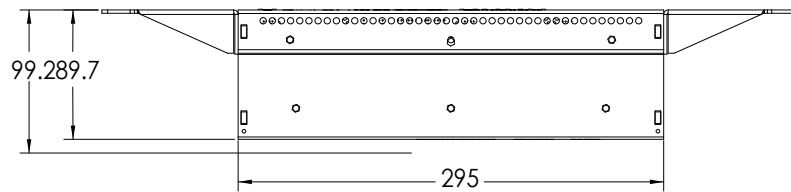
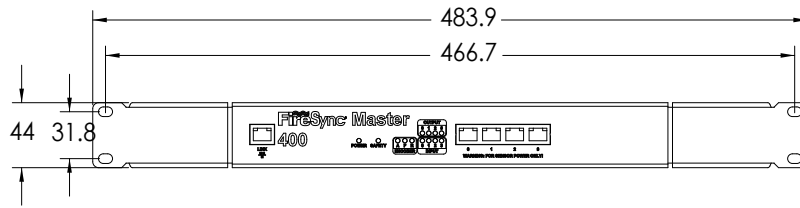

Master 1200/2400

The Master 1200/2400 provides sensor power, safety interlock and broadcasts system-wide synchronization information (i.e. time, encoder count, encoder index, and digital I/O states) to all devices on a sensor network.

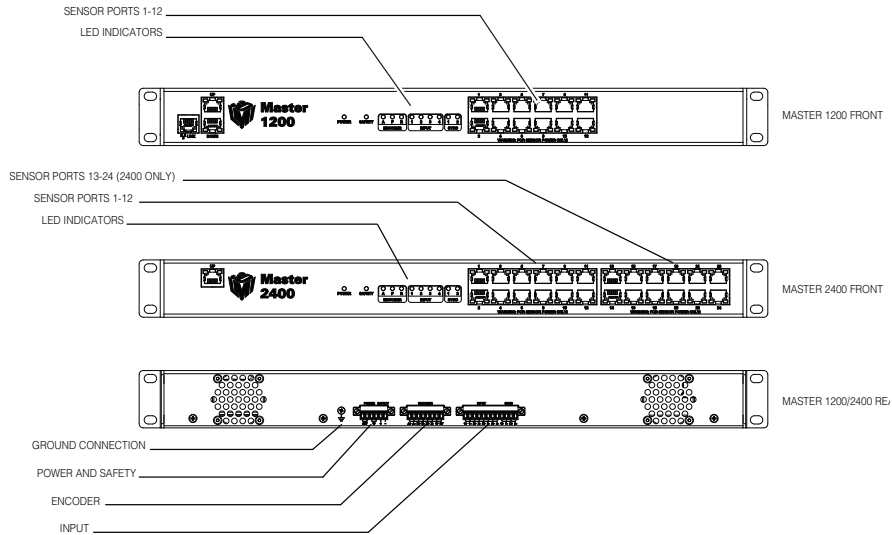

Power and Safety (6 pin connector)

Function	Pin
+48VDC	1
+48VDC	2
GND(48VDC)	3
GND(48VDC)	4
Safety Control+	5
Safety Control-	6

 The +48VDC power supply must be isolated from AC ground. This means that AC ground and DC ground are not connected.

 The Safety Control requires a voltage differential 12VDC to 48VDC across the pin to enable the laser.

Encoder (8 pin connector)

Function	Pin
Encoder_A+	1
Encoder_A-	2
Encoder_B+	3
Encoder_B-	4
Encoder_Z+	5
Encoder_Z-	6
GND	7
+5VDC	8

Digital Input (16 pin connector)

Function	Pin
Input 1	1
Input 1 GND	2
Reserved	3
Reserved	4
Reserved	5
Reserved	6
Reserved	7
Reserved	8
Reserved	9
Reserved	10
Reserved	11
Reserved	12

 This connector does not need to be wired up for proper operation.

Master 1200/2400 Electrical Specifications

Electrical specifications for Master 1200/2400:

	Master 1200	2400
Power Supply Voltage	+48VDC	
Power Supply current (Max.)	10A	
Power Draw (Min.)	15W	
Safety Voltage	+12 to +48VDC	
Encoder signal voltage range	RS485 Differential	
Digital input voltage range	Logical LOW: 0 VDC to +0.1VDC Logical HIGH: +3.5 VDC to +6.5VDC	

 When using a Master 1200/2400 it is crucial that its chassis be well grounded.

 The +48VDC power supply must be isolated from AC ground. This means that AC ground and DC ground are not connected.

 The Power Draw specification is based on a Master with no sensors attached. Every sensor has its own power requirements which need to be considered when calculating total system power requirements.

Master 1200/2400 Dimensions

Dimensions of Master 1200 and Master 2400 are the same.

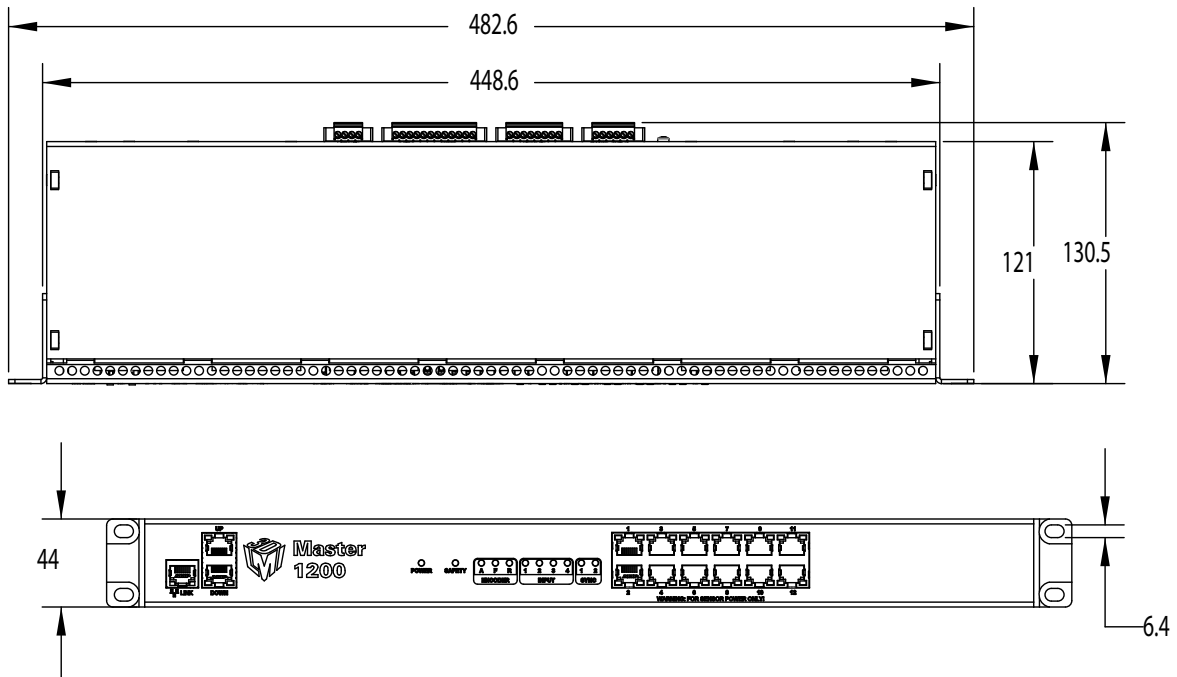

Parts and Accessories

Gocator Part Number Legend

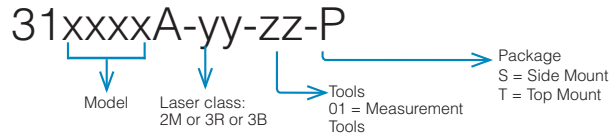

Gocator 1100 Sensors

Top Mount Package Description	Part Number
Gocator 1120 with Class 2M laser, Top Mount Package	311120A-2M-01-T
with Class 3R laser, Top Mount Package	311120A-3R-01-T
with Class 3B laser, Top Mount Package	311120A-3B-01-T
Gocator 1125 with Class 2M laser, Top Mount Package	311125A-2M-01-T
with Class 3R laser, Top Mount Package	311125A-3R-01-T
with Class 3B laser, Top Mount Package	311125A-3B-01-T
Gocator 1150 with Class 2M laser, Top Mount Package	311150A-2M-01-T
with Class 3R laser, Top Mount Package	311150A-3R-01-T
with Class 3B laser, Top Mount Package	311150A-3B-01-T
Gocator 1160 with Class 2M laser, Top Mount Package	311160A-2M-01-T
with Class 3R laser, Top Mount Package	311160A-3R-01-T
with Class 3B laser, Top Mount Package	311160A-3B-01-T
Gocator 1165 with Class 2M laser, Top Mount Package	311165A-2M-01-T
with Class 3R laser, Top Mount Package	311165A-3R-01-T
with Class 3B laser, Top Mount Package	311165A-3B-01-T
Gocator 1170 with Class 2M laser, Top Mount Package	311170A-2M-01-T
with Class 3R laser, Top Mount Package	311170A-3R-01-T
with Class 3B laser, Top Mount Package	311170A-3B-01-T
Gocator 1190 with Class 3B laser, Top Mount Package	311190A-3B-01-T
Side Mount Package Description	Part Number
Gocator 1120 with Class 2M laser, Side Mount Package	311120A-2M-01-S
with Class 3R laser, Side Mount Package	311120A-3R-01-S
with Class 3B laser, Side Mount Package	311120A-3B-01-S
Gocator 1125 with Class 2M laser, Side Mount Package	311125A-2M-01-S
with Class 3R laser, Side Mount Package	311125A-3R-01-S
with Class 3B laser, Side Mount Package	311125A-3B-01-S
Gocator 1150 with Class 2M laser, Side Mount Package	311150A-2M-01-S
with Class 3R laser, Side Mount Package	311150A-3R-01-S
with Class 3B laser, Side Mount Package	311150A-3B-01-S
Gocator 1160 with Class 2M laser, Side Mount Package	311160A-2M-01-S
with Class 3R laser, Side Mount Package	311160A-3R-01-S
with Class 3B laser, Side Mount Package	311160A-3B-01-S
Gocator 1165 with Class 2M laser, Side Mount Package	311165A-2M-01-S
with Class 3R laser, Side Mount Package	311165A-3R-01-S

Side Mount Package Description	Part Number
with Class 3B laser, Side Mount Package	311165A-3B-01-S
Gocator 1170 with Class 2M laser, Side Mount Package	311170A-2M-01-S
with Class 3R laser, Side Mount Package	311170A-3R-01-S
with Class 3B laser, Side Mount Package	311170A-3B-01-S
Gocator 1190 with Class 3B laser, Side Mount Package	311190A-3B-01-S

Gocator 1300 Sensors

Top Mount Package Description	Part Number
Gocator 1320 with Class 2M laser, Top Mount Package	311320A-2M-01-T
with Class 3R laser, Top Mount Package	311320A-3R-01-T
with Class 3B laser, Top Mount Package	311320A-3B-01-T
Gocator 1325 with Class 2M laser, Top Mount Package	311325A-2M-01-T
with Class 3R laser, Top Mount Package	311325A-3R-01-T
with Class 3B laser, Top Mount Package	311325A-3B-01-T
Gocator 1350 with Class 2M laser, Top Mount Package	311350A-2M-01-T
with Class 3R laser, Top Mount Package	311350A-3R-01-T
with Class 3B laser, Top Mount Package	311350A-3B-01-T
Gocator 1360 with Class 2M laser, Top Mount Package	311360A-2M-01-T
with Class 3R laser, Top Mount Package	311360A-3R-01-T
with Class 3B laser, Top Mount Package	311360A-3B-01-T
Gocator 1365 with Class 2M laser, Top Mount Package	311365A-2M-01-T
with Class 3R laser, Top Mount Package	311365A-3R-01-T
with Class 3B laser, Top Mount Package	311365A-3B-01-T
Gocator 1370 with Class 2M laser, Top Mount Package	311370A-2M-01-T
with Class 3R laser, Top Mount Package	311370A-3R-01-T
with Class 3B laser, Top Mount Package	311370A-3B-01-T
Gocator 1390 with Class 3B laser, Top Mount Package	311390A-3B-01-T

Side Mount Package Description	Part Number
Gocator 1320 with Class 2M laser, Side Mount Package	311320A-2M-01-S
with Class 3R laser, Side Mount Package	311320A-3R-01-S
with Class 3B laser, Side Mount Package	311320A-3B-01-S
Gocator 1325 with Class 2M laser, Side Mount Package	311325A-2M-01-S
with Class 3R laser, Side Mount Package	311325A-3R-01-S
with Class 3B laser, Side Mount Package	311325A-3B-01-S
Gocator 1350 with Class 2M laser, Side Mount Package	311350A-2M-01-S
with Class 3R laser, Side Mount Package	311350A-3R-01-S
with Class 3B laser, Side Mount Package	311350A-3B-01-S
Gocator 1360 with Class 2M laser, Side Mount Package	311360A-2M-01-S
with Class 3R laser, Side Mount Package	311360A-3R-01-S
with Class 3B laser, Side Mount Package	311360A-3B-01-S
Gocator 1365 with Class 2M laser, Side Mount Package	311365A-2M-01-S
with Class 3R laser, Side Mount Package	311365A-3R-01-S
with Class 3B laser, Side Mount Package	311365A-3B-01-S
Gocator 1370 with Class 2M laser, Side Mount Package	311370A-2M-01-S
with Class 3R laser, Side Mount Package	311370A-3R-01-S
with Class 3B laser, Side Mount Package	311370A-3B-01-S
Gocator 1390 with Class 3B laser, Side Mount Package	311390A-3B-01-S

Masters

Description	Part Number
Master 100 - for single sensor (development only)	30705
Master 400 - for networking up to 4 sensors	30680
Master 800 - for networking up to 8 sensors	30681
Master 1200 - for networking up to 12 sensors	30649
Master 2400 - for networking up to 24 sensors	30650

Cordsets

Description	Part Number
5m shielded Gocator I/O cordset, open wire end	30862
10m shielded Gocator I/O cordset, open wire end	30863
5m shielded Gocator power and Ethernet cordset, 1x open wire end, 1x RJ45 end	30859
10m shielded Gocator power and Ethernet cordset, 1x open wire end, 1x RJ45 end	30860
5m shielded Gocator power and Ethernet cordset to Master, 2x RJ45 end	30856
10m shielded Gocator power and Ethernet cordset to Master, 2x RJ45 end	30857

Contact LMI for information on creating cordsets with custom length or connector orientation. The maximum cordset length is 60m.

Warranty and Return Policy

Warranty Policy

The sensor is warranted for one year from the date of purchase from LMI Technologies Inc. Products that are found to be non-conforming during their warranty period are to be returned to LMI Technologies Inc.

The shipper is responsible for covering all duties and freight for returning the sensor to LMI. It is at LMI's discretion to repair or replace sensors that are returned for warranty work. LMI Technologies Inc. warranty covers parts, labor and return shipping charges.

If the warranty stickers on the sensors are removed or appear to be tampered with, LMI will void the warranty of the sensor.

Return Policy

Before returning the product for repair (warranty or non-warranty) a Return Material Authorization (RMA) number must be obtained from LMI. Please call LMI to obtain this RMA number.

Carefully package the sensor in its original shipping materials (or equivalent) and ship the sensor prepaid to your designated LMI location. Please ensure that the RMA number is clearly written on the outside of the package. Inside the return shipment, include the address you wish the shipment returned to, the name, email and telephone number of a technical contact (should we need to discuss this repair), and details of the nature of the malfunction. For non-warranty repairs, a purchase order for the repair charges must accompany the returning sensor.

LMI Technologies Inc. is not responsible for damages to a sensor that are the result of improper packaging or damage during transit by the courier.

Software Licenses

Pico-C

Website:

<http://code.google.com/p/picoc/>

License:

picoc is published under the "New BSD License".

<http://www.opensource.org/licenses/bsd-license.php>

*Copyright (c) 2009-2011, Zik Saleeba
All rights reserved.*

Redistribution and use in source and binary forms, with or without modification, are permitted provided that the following conditions are met:

- * Redistributions of source code must retain the above copyright notice, this list of conditions and the following disclaimer.
- * Redistributions in binary form must reproduce the above copyright notice, this list of conditions and the following disclaimer in the documentation and/or other materials provided with the distribution.
- * Neither the name of the Zik Saleeba nor the names of its contributors may be used to endorse or promote products derived from this software without specific prior written permission.

THIS SOFTWARE IS PROVIDED BY THE COPYRIGHT HOLDERS AND CONTRIBUTORS "AS IS" AND ANY EXPRESS OR IMPLIED WARRANTIES, INCLUDING, BUT NOT LIMITED TO, THE IMPLIED WARRANTIES OF MERCHANTABILITY AND FITNESS FOR A PARTICULAR PURPOSE ARE DISCLAIMED. IN NO EVENT SHALL THE COPYRIGHT OWNER OR CONTRIBUTORS BE LIABLE FOR ANY DIRECT, INDIRECT, INCIDENTAL, SPECIAL, EXEMPLARY, OR CONSEQUENTIAL DAMAGES (INCLUDING, BUT NOT LIMITED TO, PROCUREMENT OF SUBSTITUTE GOODS OR SERVICES; LOSS OF USE, DATA, OR PROFITS; OR BUSINESS INTERRUPTION) HOWEVER CAUSED AND ON ANY THEORY OF LIABILITY, WHETHER IN CONTRACT, STRICT LIABILITY, OR TORT (INCLUDING NEGLIGENCE OR OTHERWISE) ARISING IN ANY WAY OUT OF THE USE OF THIS SOFTWARE, EVEN IF ADVISED OF THE POSSIBILITY OF SUCH DAMAGE.

BlowFish

Website:

<http://www.chiark.greenend.org.uk/~sgtatham/putty/licence.html>

License:

PuTTY is copyright 1997-2011 Simon Tatham.

Portions copyright Robert de Bath, Joris van Rantwijk, Delian Delchev, Andreas Schultz, Jeroen Massar, Wez Furlong, Nicolas Barry, Justin Bradford, Ben Harris, Malcolm Smith, Ahmad Khalifa, Markus Kuhn, Colin Watson, and CORE SDI S.A.

Permission is hereby granted, free of charge, to any person obtaining a copy of this software and associated documentation files (the "Software"), to deal in the Software without restriction, including without limitation the rights to use, copy, modify, merge, publish, distribute, sublicense, and/or sell copies of the Software, and to permit persons to whom the Software is furnished to do so, subject to the following conditions:

The above copyright notice and this permission notice shall be included in all copies or substantial portions of the Software.

THE SOFTWARE IS PROVIDED "AS IS", WITHOUT WARRANTY OF ANY KIND, EXPRESS OR IMPLIED, INCLUDING BUT NOT LIMITED TO THE WARRANTIES OF MERCHANTABILITY, FITNESS FOR A PARTICULAR PURPOSE AND NONINFRINGEMENT. IN NO EVENT SHALL SIMON TATHAM BE LIABLE FOR ANY CLAIM, DAMAGES OR OTHER LIABILITY, WHETHER IN AN ACTION OF CONTRACT, TORT OR OTHERWISE, ARISING FROM, OUT OF OR IN CONNECTION WITH THE SOFTWARE OR THE USE OR OTHER DEALINGS IN THE SOFTWARE.

CodeMirror

Website:

<http://codemirror.net>

License:

Copyright (C) 2011 by Marijn Haverbeke <marijnh@gmail.com>

Permission is hereby granted, free of charge, to any person obtaining a copy of this software and associated documentation files (the "Software"), to deal in the Software without restriction, including without limitation the rights to use, copy, modify, merge, publish, distribute, sublicense, and/or sell copies of the Software, and to permit persons to whom the Software is furnished to do so, subject to the following conditions:

The above copyright notice and this permission notice shall be included in all copies or substantial portions of the Software.

THE SOFTWARE IS PROVIDED "AS IS", WITHOUT WARRANTY OF ANY KIND, EXPRESS OR IMPLIED, INCLUDING BUT NOT LIMITED TO THE WARRANTIES OF MERCHANTABILITY, FITNESS FOR A PARTICULAR PURPOSE AND NONINFRINGEMENT. IN NO EVENT SHALL THE AUTHORS OR COPYRIGHT HOLDERS BE LIABLE FOR ANY CLAIM, DAMAGES OR OTHER LIABILITY, WHETHER IN AN ACTION OF CONTRACT, TORT OR OTHERWISE, ARISING FROM, OUT OF OR IN CONNECTION WITH THE SOFTWARE OR THE USE OR OTHER DEALINGS IN THE SOFTWARE.

jQuery

Website:

<http://jquery.com/>

License:

Copyright (c) 2011 John Resig, <http://jquery.com/>

Permission is hereby granted, free of charge, to any person obtaining a copy of this software and associated documentation files (the "Software"), to deal in the Software without restriction, including without limitation the rights to use, copy, modify, merge, publish, distribute, sublicense, and/or sell copies of the Software, and to permit persons to whom the Software is furnished to do so, subject to the following conditions:

The above copyright notice and this permission notice shall be included in all copies or substantial portions of the Software.

THE SOFTWARE IS PROVIDED "AS IS", WITHOUT WARRANTY OF ANY KIND, EXPRESS OR IMPLIED, INCLUDING BUT NOT LIMITED TO THE WARRANTIES OF MERCHANTABILITY, FITNESS FOR A PARTICULAR PURPOSE AND NONINFRINGEMENT. IN NO EVENT SHALL THE AUTHORS OR COPYRIGHT HOLDERS BE LIABLE FOR ANY CLAIM, DAMAGES OR OTHER LIABILITY, WHETHER IN AN ACTION OF CONTRACT, TORT OR OTHERWISE, ARISING FROM, OUT OF OR IN CONNECTION WITH THE SOFTWARE OR THE USE OR OTHER DEALINGS IN THE SOFTWARE.

Closure Library

Website:

<http://code.google.com/closure/library/index.html>

License:

Copyright 2006 The Closure Library Authors. All Rights Reserved.

Licensed under the Apache License, Version 2.0 (the "License"); you may not use this file except in compliance with the License.

You may obtain a copy of the License at <http://www.apache.org/licenses/LICENSE-2.0>

Unless required by applicable law or agreed to in writing, software distributed under the License is distributed on an "AS-IS" BASIS, WITHOUT WARRANTIES OR CONDITIONS OF ANY KIND, either express or implied. See the License for the specific language governing permissions and limitations under the License.

jQuery.CopyEvents

Website:

<http://brandonaaron.net>

License:

Copyright (c) 2006 Brandon Aaron

Licensed under the MIT License (<http://www.opensource.org/licenses/mit-license.php>)

jQuery.history

License:

jQuery history plugin

Copyright (c) 2006 Taku Sano (Mikage Sawatari)

Licensed under the MIT License (<http://www.opensource.org/licenses/mit-license.php>)

Modified by Lincoln Cooper to add Safari support and only call the callback once during initialization for msie when no initial hash supplied. API rewrite by Lauris Bukis-Haberkorns

jQuery.mouseWheel

Website:

<http://brandonaaron.net>

License:

Copyright (c) 2010 Brandon Aaron

Licensed under the MIT License (<http://www.opensource.org/licenses/mit-license.php>)

jQuery.scaling

Website:

<http://eric.garside.name>

License:

Scaling 1.0 - Scale any page element

Copyright (c) 2009 Eric Garside

Licensed under the MIT License (<http://www.opensource.org/licenses/mit-license.php>)

jQuery.scrollFollow

Website:

<http://kitchen.net-perspective.com/>

License:

Copyright (c) 2008 Net Perspective

Licensed under the MIT License (<http://www.opensource.org/licenses/mit-license.php>)

Flex SDK

Website:

<http://opensource.adobe.com/wiki/display/flexsdk/Flex+SDK>

License:

Copyright (c) 2010 Adobe Systems Incorporated

The contents of this file are subject to the Mozilla Public License Version 1.1 (the "License"); you may not use this file except in compliance with the License. You may obtain a copy of the License at <http://www.mozilla.org/MPL/>

Software distributed under the License is distributed on an "AS IS" basis, WITHOUT WARRANTY OF ANY KIND, either express or implied. See the License for the specific language governing rights and limitations under the License.

EtherNet/IP Communication Stack

Website:

sourceforge.net/projects/opener

License:

SOFTWARE DISTRIBUTION LICENSE FOR THE
ETHERNET/IP(TM) COMMUNICATION STACK (ADAPTED BSD STYLE LICENSE)

Copyright (c) 2009, Rockwell Automation, Inc. ALL RIGHTS RESERVED.

EtherNet/IP is a trademark of ODVA, Inc.

Support

For assistance regarding a component or product, please contact LMI Technologies.

World

Email support@lmi3d.com

Web <http://www.lmi3d.com>

North America

Phone +1 604 636 1011

Fax +1 604 516 8368

Europe

Phone +31 45 850 7000

Fax +31 45 574 2500

For more information on safety and laser classifications, please contact:

*U.S. Food and Drug Administration
Center for Devices and Radiological Health
WO66-G609
10903 New Hampshire Avenue
Silver Spring, MD 20993-0002
USA*

**North America**

LMI Technologies Inc.
1673 Cliveden Avenue
Delta BC V3M 6V5
Canada
Phone: +1 604 636 1011
Fax: +1 604 516 8368

Europe

LMI Technologies BV
Valkenburgerweg 223
NL-6419AT Heerlen
The Netherlands
Phone: +31 45 850 7000
Fax: +31 45 574 2500