



USER MANUAL

# Gocator 2000 & 2300 Series

Document revision: A

# Copyright

Copyright © 2015 by LMI Technologies, Inc. All rights reserved.

## **Proprietary**

This document, submitted in confidence, contains proprietary information which shall not be reproduced or transferred to other documents or disclosed to others or used for manufacturing or any other purpose without prior written permission of LMI Technologies Inc.

No part of this publication may be copied, photocopied, reproduced, transmitted, transcribed, or reduced to any electronic medium or machine readable form without prior written consent of LMI Technologies, Inc.

## **Trademarks and Restrictions**

Gocator™ is a registered trademark of LMI Technologies, Inc. Any other company or product names mentioned herein may be trademarks of their respective owners.

Information contained within this manual is subject to change.

This product is designated for use solely as a component and as such it does not comply with the standards relating to laser products specified in U.S. FDA CFR Title 21 Part 1040.

## **Contact Information**

For more information, please contact LMI Technologies.

LMI Technologies, Inc. 1673 Cliveden Ave.

Delta, BC V3M 6V5

Canada

Telephone: +1 604 636 1011

Facsimile: +1 604 516 8368

[www.lmi3d.com](http://www.lmi3d.com)

# Table of Contents

<b>Copyright</b> .....	<b>2</b>
<b>Table of Contents</b> .....	<b>3</b>
<b>Introduction</b> .....	<b>9</b>
<b>Safety and Maintenance</b> .....	<b>10</b>
Laser Safety .....	10
Laser Classes .....	11
Precautions and Responsibilities .....	11
Class 3B Responsibilities .....	12
Nominal Ocular Hazard Distance (NOHD) .....	13
Systems Sold or Used in the USA .....	14
Electrical Safety .....	14
Environment and Lighting .....	15
Sensor Maintenance .....	16
<b>Getting Started</b> .....	<b>17</b>
System Overview .....	17
Standalone System .....	17
Dual-Sensor System .....	17
Multi-Sensor System .....	19
Hardware Overview .....	21
Gocator 2000 Sensor .....	21
Gocator 2300 & 2880 Sensor .....	21
Gocator 2000 Cordsets .....	22
Gocator 2300 & 2880 Cordsets .....	22
Master 100 .....	23
Master 200 .....	24
Master 400/800 .....	24
Master 1200/2400 .....	25
Calibration Targets .....	26
Installation .....	28
Grounding - Gocator .....	28
Recommended Grounding Practices - Cordsets .....	28
Grounding - Master 400/800/1200/2400 .....	29
Mounting .....	29
Orientations .....	30
Network Setup .....	33
Client Setup .....	33
Gocator Setup .....	35
Running a Standalone Sensor System .....	35
Running a Dual-Sensor System .....	37
Next Steps .....	40

<b>Theory of Operation</b> .....	<b>41</b>
3D Acquisition .....	41
Principle of 3D Acquisition .....	41
Resolution and Accuracy .....	42
X Resolution .....	42
Z Resolution .....	42
Z Linearity .....	43
Profile Output .....	44
Coordinate Systems .....	44
Sensor Coordinates .....	44
System Coordinates .....	44
Resampled and Raw Profile Format .....	45
<b>Gocator Web Interface</b> .....	<b>46</b>
User Interface Overview .....	46
Common Elements .....	47
Toolbar .....	47
Saving and Loading Settings .....	47
Managing Multiple Settings .....	49
Recording, Playback, and Measurement Simulation .....	50
Downloading, Exporting, and Uploading Recorded Data .....	51
Metrics Panel .....	52
Data Viewer .....	53
Connection and Maintenance .....	54
Connection Page Overview .....	54
System Panel .....	54
Network Settings .....	54
Sensor Autostart .....	55
Overheat Temperature Protection .....	55
Available Sensors .....	56
Buddy Assignment .....	56
Security Panel .....	57
Files Panel .....	58
Maintenance Panel .....	58
Sensor Backups and Factory Reset .....	59
Firmware Upgrade .....	60
Setup and Calibration .....	62
Setup Page Overview .....	62
Operation Mode Panel .....	64
Trigger Panel .....	64
Trigger Examples .....	66
Trigger Settings .....	67

Sensor Panel .....	69	Measurement Management .....	97
Active Area .....	69	Measurement Name .....	97
Tracking Window .....	70	Measurement ID .....	98
Exposure .....	71	Profile Sources .....	98
Single Exposure .....	72	Measurement Tool Linking .....	99
Dynamic Exposure .....	73	Common Measurement Parameters .....	99
Multiple Exposures .....	74	Profile Sources .....	100
Resolutions .....	75	Decisions .....	100
X Resolution .....	76	Regions .....	101
Z Resolution .....	76	Output Filters .....	102
Transformations .....	76	Profile Measurement .....	103
Layout Panel .....	77	Feature Points .....	103
Dual-Sensor System Layout .....	77	Fit Lines .....	105
Overlap .....	78	Tools and Measurements .....	105
Reverse .....	78	Width .....	105
Calibration .....	78	Height .....	106
Calibration States .....	79	Distance .....	107
Transformation Sources .....	79	Position .....	108
Alignment vs. Travel Calibration .....	80	Center .....	109
Alignment Calibration .....	80	Angle .....	110
Travel Calibration .....	81	Intersect .....	111
Clearing Calibration .....	82	Area .....	112
Filters Panel .....	82	Difference .....	114
Smoothing .....	83	Circle .....	115
Gap Filling .....	83	Line .....	116
X Resampling Interval .....	84	Gap and Flush .....	117
Detection Panel .....	85	Gap .....	117
Data Viewer .....	86	Flush .....	119
Video Mode .....	86	Groove .....	120
Exposure Mode View .....	87	Strip .....	123
Profile and Raw Mode .....	88	Tilt .....	126
Whole Part Mode .....	89	Script .....	127
Region Definition .....	91	Whole Part Measurement .....	128
Data Viewer Controls .....	91	Tools and Measurements .....	128
Height Map Color Scale .....	92	Volume .....	128
Intensity Output .....	92	Area .....	130
Measurement .....	94	Ellipse .....	131
Measurement Page Overview .....	94	Height .....	132
Tools Panel .....	95	Bounding Box .....	133
Adding and Removing Measurements .....	95	Hole .....	136
Profile Fixturing .....	95	Measurement Region .....	139
Data Viewer .....	97	Stud .....	140

Measurement Region .....	142	Measurements / IntersectZ .....	186
Opening .....	142	Measurements / IntersectAngle .....	187
Measurement Region .....	147	Measurements / IntersectArea .....	187
Plane .....	147	Measurements / BoxArea .....	188
Position .....	148	Measurements / Difference Area .....	189
Texture .....	150	Measurements / Difference Peak .....	190
Script .....	151	Measurements / Circle Radius .....	190
Script Measurement .....	152	Measurements / Circle X .....	191
Built-in Functions .....	153	Measurements / Circle Z .....	192
Output .....	157	Measurements / Line Standard Deviation ..	193
Output Page Overview .....	157	Measurements / Line Error Min .....	193
Ethernet Output .....	157	Measurements / Line Error Max .....	194
Digital Outputs .....	161	Measurements / Line Percentile .....	195
Analog Output .....	164	Measurements / Gap .....	196
Serial Output .....	166	Measurements / Flush .....	197
Dashboard .....	168	Measurements / Groove Width .....	198
Dashboard Page Overview .....	168	Measurements / Groove X .....	199
State and Health Information .....	168	Measurements / Groove Z .....	200
Measurement Statistics .....	169	Measurements / Groove Depth .....	201
<b>Gocator Device Files .....</b>	<b>171</b>	Measurements / Strip X .....	202
Configuration Files .....	171	Measurements / Strip Z .....	204
Setup .....	171	Measurements / Strip Width .....	205
Trigger .....	172	Measurements / Strip Height .....	207
Layout .....	173	Measurements / Script .....	208
Calibration .....	173	Part .....	209
Filters .....	174	Detection .....	209
Sensors / Sensor .....	175	PartRegion .....	210
Sensors / Sensor / Profiling .....	175	PartRegion3D .....	210
Profile .....	177	SurfaceCircleRegion .....	210
Area .....	177	SurfaceFeature3d .....	210
Feature .....	178	Measurements / PartArea .....	211
Line .....	178	Measurements / PartVolume .....	212
Anchor .....	178	Measurements / PartHeight .....	212
Measurements / Width .....	179	Measurements / PartEllipseMajor .....	213
Measurements / Height .....	180	Measurements / PartEllipseMinor .....	214
Measurements / Distance .....	181	Measurements / PartEllipseAngle .....	215
Measurements / PositionX .....	181	Measurements / PartEllipseRatio .....	216
Measurements / PositionZ .....	182	Measurements / PartBoundingBoxX .....	216
Measurements / CenterX .....	183	Measurements / PartBoundingBoxY .....	217
Measurements / CenterZ .....	184	Measurements / PartBoundingBoxWidth ..	218
Measurements / AngleX .....	184	Measurements / PartBoundingBoxLength ..	219
Measurements / IntersectX .....	185	Measurements / PartBoundingBoxAngle ..	220

Measurements / PartHoleX .....	221	States .....	255
Measurements / PartHoleY .....	222	Versions and Upgrades .....	255
Measurements / PartHoleZ .....	223	Data Types .....	256
Measurements / PartHoleRadius .....	224	Profile Sources .....	256
Measurements / PartOpeningX .....	225	Status Codes .....	256
Measurements / PartOpeningY .....	226	Command and Reply Formats .....	257
Measurements / PartOpeningZ .....	228	Result Format .....	257
Measurements / PartOpeningLength .....	229	Discovery Commands .....	258
Measurements / PartOpeningAngle .....	231	Get Address .....	258
Measurements / PartStudTipX .....	232	Set Address .....	259
Measurements / PartStudTipY .....	233	Upgrade Commands .....	259
Measurements / PartStudTipZ .....	234	Get Protocol Version .....	259
Measurements / PartStudBaseX .....	236	Start Upgrade .....	260
Measurements / PartStudBaseY .....	237	Get Upgrade Status .....	260
Measurements / PartStudBaseZ .....	238	Get Upgrade Log .....	261
Measurements / PartStudBaseRadius .....	239	Control Commands .....	261
Measurements / SurfacePlaneXAngle .....	240	Get Protocol Version .....	261
Measurements / SurfacePlaneYAngle .....	241	Get System Info .....	262
Measurements / SurfacePlaneZOffset .....	242	Log In/Out .....	263
Measurements / PartPositionX .....	243	Change Password .....	263
Measurements / PartPositionY .....	243	Change Buddy .....	264
Measurements / PartPositionZ .....	244	Get File List .....	264
Measurements / SurfaceTextureRoughness .....	245	Copy File .....	265
Measurements /		Read File .....	265
SurfaceTextureInvalidCount .....	246	Write File .....	266
Measurements / Script .....	246	Delete File .....	266
Outputs .....	246	Get Default File .....	267
Ethernet .....	247	Set Default File .....	267
Serial .....	248	Get Loaded File .....	268
Analog .....	249	Get Mode .....	268
DigitalOutput .....	250	Set Mode .....	268
Calibration File .....	251	Get Time .....	269
SysCal .....	251	Get Encoder .....	269
Entries .....	252	Start .....	269
<b>Protocols .....</b>	<b>253</b>	Scheduled Start .....	270
Gocator Protocol .....	253	Stop .....	270
Concepts .....	253	Trigger .....	271
Discovery .....	253	Scheduled Digital Output .....	271
Command Channels .....	254	Scheduled Analog Output .....	272
Result Channels .....	254	Ping .....	272
Modes .....	254	Reset .....	273
Buddy Communication Channels .....	255	Backup .....	273

Restore .....	273	Control Commands .....	301
Restore Factory .....	274	Start .....	301
Get Connection Type .....	274	Stop .....	301
Set Connection Type .....	275	Trigger .....	302
Clear Calibration .....	275	Load Configuration .....	302
Data Results .....	276	Stamp .....	303
Video .....	276	Alignment Calibration .....	303
Profile .....	277	Travel Calibration .....	304
Profile Intensity .....	277	Clear Calibration .....	304
Part Profile .....	278	Data Commands .....	304
Part Intensity .....	278	Get Result .....	305
Alignment Calibration .....	279	Get Value .....	305
Travel Calibration .....	279	Get Decision .....	306
Exposure Calibration .....	279	Health Commands .....	307
Measurement .....	279	Get Health .....	307
Health Results .....	281	<b>Software Development Kit .....</b>	<b>308</b>
Modbus TCP Protocol .....	285	Limiting Flash Memory Write Operations .....	309
Concepts .....	285	<b>Tools and Native Drivers .....</b>	<b>311</b>
Messages .....	285	Sensor Recovery Tool .....	311
Registers .....	286	GenTL Driver .....	313
Control Registers .....	287	16-bit RGB Image .....	314
Output Registers .....	288	16-bit Grey Scale Image .....	315
Measurement Registers .....	289	Registers .....	316
EtherNet/IP Protocol .....	291	XML Settings File .....	318
Concepts .....	291	CSV Converter Tool .....	318
Basic Object .....	291	<b>Troubleshooting .....</b>	<b>320</b>
Identity Object (Class 0x01) .....	291	<b>Specifications .....</b>	<b>322</b>
TCP/IP Object (Class 0xF5) .....	292	Gocator 2000 Series .....	322
Ethernet Link Object (Class 0xF6) .....	292	Gocator 2020 .....	323
Assembly Object (Class 0x04) .....	293	Gocator 2030 .....	324
Command Assembly .....	293	Gocator 2040 .....	325
Sensor State Assembly .....	294	Gocator 2050 .....	326
Sample State Assembly .....	295	Gocator 2070 .....	329
Extended Sample State Assembly .....	296	Gocator 2075 .....	331
ASCII Protocol .....	298	Gocator 2080 .....	334
Ethernet Communication .....	298	Gocator 2300 Series .....	336
Asynchronous and Polling Operation .....	298	Gocator 2330 .....	337
Serial Communication .....	298	Gocator 2340 .....	339
Command and Reply Format .....	299	Gocator 2350 .....	340
Special Characters .....	299	Gocator 2370 .....	342
Standard Result Format .....	300	Gocator 2375 .....	345
Custom Result Format .....	300	Gocator 2380 .....	347

---

Gocator 2000 I/O Connector .....	350
Grounding Shield .....	351
Power .....	351
Laser Safety Input .....	351
Digital Outputs .....	351
Inverting Outputs .....	352
Digital Inputs .....	352
Encoder Input .....	353
Serial Output .....	354
Analog Output .....	354
Gocator Power/LAN Connector .....	356
Grounding Shield .....	356
Power .....	357
Laser Safety Input .....	357
Gocator 2300 I/O Connector .....	358
Grounding Shield .....	359
Digital Outputs .....	359
Inverting Outputs .....	359
Digital Inputs .....	359
Encoder Input .....	360
Serial Output .....	361
Analog Output .....	361
Master 100 .....	363
Master 100 Dimensions .....	364
Master 200 .....	365
Master 200 Dimensions .....	367
Master 400/800 .....	368
Master 400/800 Electrical Specifications .....	369
Master 400/800 Dimensions .....	370
Master 1200/2400 .....	371
Master 1200/2400 Electrical Specifications .....	372
Master 1200/2400 Dimensions .....	373
<b>Parts and Accessories .....</b>	<b>374</b>
<b>Return Policy .....</b>	<b>377</b>
<b>Software Licenses .....</b>	<b>378</b>
<b>Support .....</b>	<b>384</b>
<b>Contact .....</b>	<b>385</b>

# Introduction

The Gocator 2000 and 2300 series of laser profiling sensors is designed for 3D measurement and control applications. Gocator sensors are configured using a web browser and can be connected to a variety of input and output devices.

This documentation describes how to connect, configure, and use a Gocator. It also contains reference information on the device's protocols and configuration files.

## Notational Conventions

This guide uses the following notational conventions:



Follow these safety guidelines to avoid potential injury or property damage.



Consider this information in order to make best use of the product.

# Safety and Maintenance

The following sections describe the safe use and maintenance of Gocator sensors.

## Laser Safety

Gocator sensors contain semiconductor lasers that emit visible or invisible light and are designated as Class 2M, Class 3R, or Class 3B, depending on the chosen laser option. Gocator sensors are referred to as *components*, indicating that they are sold only to qualified customers for incorporation into their own equipment. These sensors do not incorporate safety items that the customer may be required to provide in their own equipment (e.g., remote interlocks, key control; refer to references for detailed information). As such, these sensors do not fully comply with the standards relating to laser products specified in IEC 60825-1 and FDA CFR Title 21 Part 1040.

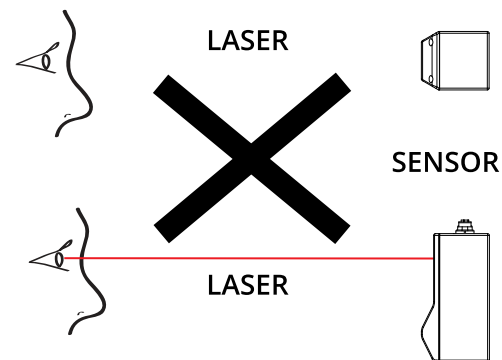

**WARNING: DO NOT LOOK DIRECTLY INTO THE LASER BEAM**

 Use of controls or adjustments or performance of procedures other than those specified herein may result in hazardous radiation exposure.

## References

1. *International standard IEC 60825-1 (2001-08) consolidated edition, Safety of laser products – Part 1: Equipment classification, requirements and user's guide.*
2. *Technical report 60825-10, Safety of laser products – Part 10. Application guidelines and explanatory notes to IEC 60825-1.*
3. *Laser Notice No. 50, FDA and CDRH <http://www.fda.gov/cdrh/rad-health.html>*

## Laser Classes

### Class 2M laser components

Class 2M laser components would not cause permanent damage to the eye under reasonably foreseeable conditions of operation, provided that any exposure can be terminated by the blink reflex (assumed to take 0.25 seconds). Because classification assumes the blink reflex, the wavelength of light must be in the visible range (400 nm to 700 nm). The Maximum Permissible Exposure (MPE) for visible radiation for 0.25 seconds is 25 watts per square meter, which is equivalent to 1 mW entering an aperture of 7 mm diameter (the assumed size of the pupil).

### Class 3R laser components

Class 3R laser products emit radiation where direct intrabeam viewing is potentially hazardous, but the risk is lower with 3R lasers than for 3B lasers. Fewer manufacturing requirements and control measures for 3R laser users apply than for 3B lasers.

### Class 3B laser components

Class 3B components are unsafe for eye exposure. Usually only ocular protection will be required. Diffuse reflections are safe if viewed for less than 10 seconds.

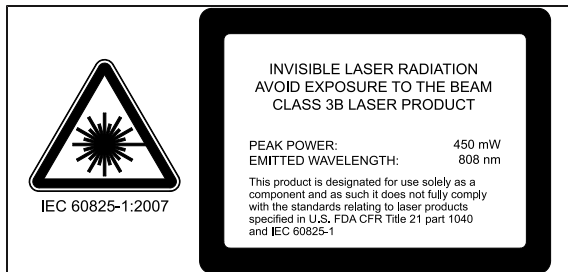
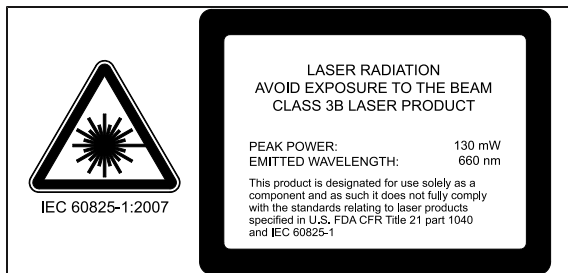
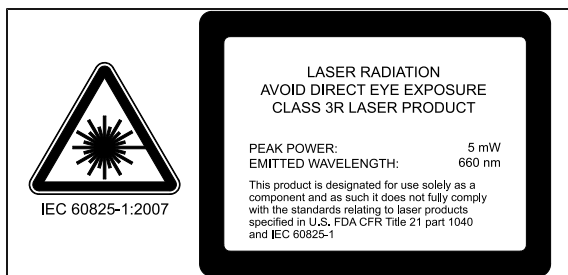
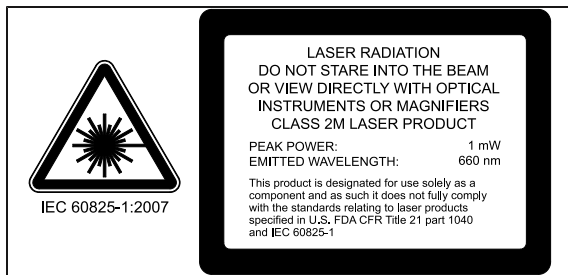

Labels reprinted here are examples only. For accurate specifications, refer to the label on your sensor.

## Precautions and Responsibilities

Precautions specified in IEC 60825-1 and FDA CFR Title 21 Part 1040 are as follows:

Requirement	Class 2M	Class 3R	Class 3B
Remote interlock	Not required	Not required	Required*
Key control	Not required	Not required	Required – cannot remove key when in use*
Power-on delays	Not required	Not required	Required*
Beam attenuator	Not required	Not required	Required*
Emission indicator	Not required	Not required	Required*
Warning signs	Not required	Not required	Required*
Beam path	Not required	Terminate beam at useful length	Terminate beam at useful length
Specular reflection	Not required	Prevent unintentional reflections	Prevent unintentional reflections
Eye protection	Not required	Not required	Required under special conditions
Laser safety officer	Not required	Not required	Required
Training	Not required	Required for operator and maintenance personnel	Required for operator and maintenance personnel

*\*LMI Class 3B laser components do not incorporate these laser safety items. These items must be added and completed by customers in their system design.*

## Class 3B Responsibilities

LMI Technologies has filed reports with the FDA to assist customers in achieving certification of laser products. These reports can be referenced by an accession number, provided upon request. Detailed descriptions of the safety items that must be added to the system design are listed below.

### Remote Interlock

A remote interlock connection must be present in Class 3B laser systems. This permits remote switches to be attached in serial with the keylock switch on the controls. The deactivation of any remote switches must prevent power from being supplied to any lasers.

### Key Control

A key operated master control to the lasers is required that prevents any power from being supplied to the lasers while in the OFF position. The key can be removed in the OFF position but the switch must not allow the key to be removed from the lock while in the ON position.

### Power-On Delays

A delay circuit is required that illuminates warning indicators for a short period of time before supplying power to the lasers.

### Beam Attenuators

A permanently attached method of preventing human access to laser radiation other than switches, power connectors or key control must be employed. On some LMI laser sensors, the beam attenuator is

supplied with the sensor as an integrated mechanical shutter.

### Emission Indicator

It is required that the controls that operate the sensors incorporate a visible or audible indicator when power is applied and the lasers are operating. If the distance between the sensor and controls is more than 2 meters, or mounting of sensors intervenes with observation of these indicators, then a second power-on indicator should be mounted at some readily-observable position. When mounting the warning indicators, it is important not to mount them in a location that would require human exposure to the laser emissions. User must ensure that the emission indicator, if supplied by OEM, is visible when viewed through protective eyewear.

### Warning Signs

Laser warning signs must be located in the vicinity of the sensor such that they will be readily observed.

Examples of laser warning signs are as follows:



*FDA warning sign example*



*IEC warning sign example*

## Nominal Ocular Hazard Distance (NOHD)

Nominal Ocular Hazard Distance (NOHD) is the distance from the source at which the intensity or the energy per surface unit becomes lower than the Maximum Permissible Exposure (MPE) on the cornea and on the skin.

 The laser beam is considered dangerous if the operator is closer to the source than the NOHD.

The following table shows example calculations of the NOHD values for each Gocator model and laser class, assuming continuous operation of the laser. As a configurable device the Gocator allows the user to set the laser exposure (laser on-time) independently of the frame period (total cycle time for data acquisition). Continuous operation of the laser means that the laser exposure is configured to be identical to the frame period, which is also referred to as 100% duty cycle. However, in many applications the laser exposure can be smaller than the frame period (less than 100% duty cycle) thereby reducing the NOHD.

The table therefore shows the worst-case NOHD.

Model	Laser Class	Model Constant	Class I MPE (mW)	Class II MPE (mw)	Class I NOHD (mm)	Class II NOHD (mm)
2x20	2M	101	0.39	0.98	259	103

Model	Laser Class	Model Constant	Class I MPE (mW)	Class II MPE (mw)	Class I NOHD (mm)	Class II NOHD (mm)
2x30	2M	101	0.39	0.98	259	103
	3R	351	0.39	0.98	900	358
	3B	2246	0.39	0.98	5759	2292
2x40	2M	101	0.39	0.98	259	103
	3R	351	0.39	0.98	900	358
	3B	2246	0.39	0.98	5759	2292
2x50	2M	101	0.39	0.98	259	103
	3R	351	0.39	0.98	900	358
	3B	2246	0.39	0.98	5759	2292
2x70	2M	98	0.39	0.98	251	100
	3R	341	0.39	0.98	875	348
	3B	1422	0.39	0.98	3645	1451
2x80	2M	95	0.39	0.98	245	97
	3R	335	0.39	0.98	859	342
	3B	1031	0.39	0.98	2645	1052

To calculate the NOHD value for a specific laser class, use the following formula:

$$\text{NOHD} = \text{Model Constant} / \text{MPE}$$

Model Constant includes a consideration of the fan angle for the individual models.

## Systems Sold or Used in the USA

Systems that incorporate laser components or laser products manufactured by LMI Technologies require certification by the FDA.

Customers are responsible for achieving and maintaining this certification.

Customers are advised to obtain the information booklet *Regulations for the Administration and Enforcement of the Radiation Control for Health and Safety Act of 1968: HHS Publication FDA 88-8035*.

This publication, containing the full details of laser safety requirements, can be obtained directly from the FDA, or downloaded from their web site at <http://www.fda.gov/cdrh>.

## Electrical Safety



Failure to follow the guidelines described in this section may result in electrical shock or equipment damage.

### Sensors should be connected to earth ground

All sensors should be connected to earth ground through their housing. All sensors should be mounted on an earth grounded frame using electrically conductive hardware to ensure the housing of the sensor

is connected to earth ground. Use a multi-meter to check the continuity between the sensor connector and earth ground to ensure a proper connection.

### **Minimize voltage potential between system ground and sensor ground**

Care should be taken to minimize the voltage potential between system ground (ground reference for I/O signals) and sensor ground. This voltage potential can be determined by measuring the voltage between Analog\_out- and system ground. The maximum permissible voltage potential is 12 V but should be kept below 10 V to avoid damage to the serial and encoder connections.

See *Gocator 2000 I/O Connector* (page 350) for a description of connector pins used with Gocator 2000 series sensors.

See *Gocator 2300 I/O Connector* (page 358) for a description of connector pins used with Gocator 2300 series sensors.

### **Use a suitable power supply**

The +24 to +48 VDC power supply used with Gocator sensors should be an isolated supply with inrush current protection or be able to handle a high capacitive load.

### **Use care when handling powered devices**

Wires connecting to the sensor should not be handled while the sensor is powered. Doing so may cause electrical shock to the user or damage to the equipment.

## **Environment and Lighting**

### **Avoid strong ambient light sources**

The imager used in this product is highly sensitive to ambient light hence stray light may have adverse effects on measurement. Do not operate this device near windows or lighting fixtures that could influence measurement. If the unit must be installed in an environment with high ambient light levels, a lighting shield or similar device may need to be installed to prevent light from affecting measurement.

### **Avoid installing sensors in hazardous environments**

To ensure reliable operation and to prevent damage to Gocator sensors, avoid installing the sensor in locations

- that are humid, dusty, or poorly ventilated;
- with a high temperature, such as places exposed to direct sunlight;
- where there are flammable or corrosive gases;
- where the unit may be directly subjected to harsh vibration or impact;
- where water, oil, or chemicals may splash onto the unit;
- where static electricity is easily generated.

### **Ensure that ambient conditions are within specifications**

Gocator sensors are suitable for operation between 0–50° C and 25–85% relative humidity (non-condensing). Measurement error due to temperature is limited to 0.015% of full scale per degree C.

The Master 200/400/800/1200/2400 is similarly rated for operation between 0–50° C.

The storage temperature is -30–70° C.



The sensor must be heat-sunk through the frame it is mounted to. When a sensor is properly heat sunk, the difference between ambient temperature and the temperature reported in the sensor's health channel is less than 15° C.



Gocator sensors are high-accuracy devices, and the temperature of all of its components must therefore be in equilibrium. When the sensor is powered up, a warm-up time of at least one hour is required to reach a consistent spread of temperature in the sensor.

## Sensor Maintenance

### Keep sensor windows clean

Gocator sensors are high-precision optical instruments. To ensure the highest accuracy is achieved in all measurements, the windows on the front of the sensor should be kept clean and clear of debris.

### Use care when cleaning sensor windows

Use dry, clean air to remove dust or other dirt particles. If dirt remains, clean the windows carefully with a soft, lint-free cloth and non-streaking glass cleaner or isopropyl alcohol. Ensure that no residue is left on the windows after cleaning.

### Turn off lasers when not in use

LMI Technologies uses semiconductor lasers in 3D measurement sensors. To maximize the lifespan of the sensor, turn off the laser when not in use.

### Avoid excessive modifications to files stored on the sensor

Settings for Gocator sensors are stored in flash memory inside the sensor. Flash memory has an expected lifetime of 100,000 writes. To maximize lifetime, avoid frequent or unnecessary file save operations.

# Getting Started

The following sections provide system and hardware overviews, in addition to installation and setup procedures.

## System Overview

Gocator sensors can be installed and used in a variety of scenarios. Sensors can be connected as standalone devices, dual-sensor systems, or multi-sensor systems.

### Standalone System

Standalone systems are typically used when only a single Gocator sensor is required. The sensor can be connected to a computer's Ethernet port for setup and can also be connected to devices such as encoders, photocells, or PLCs.

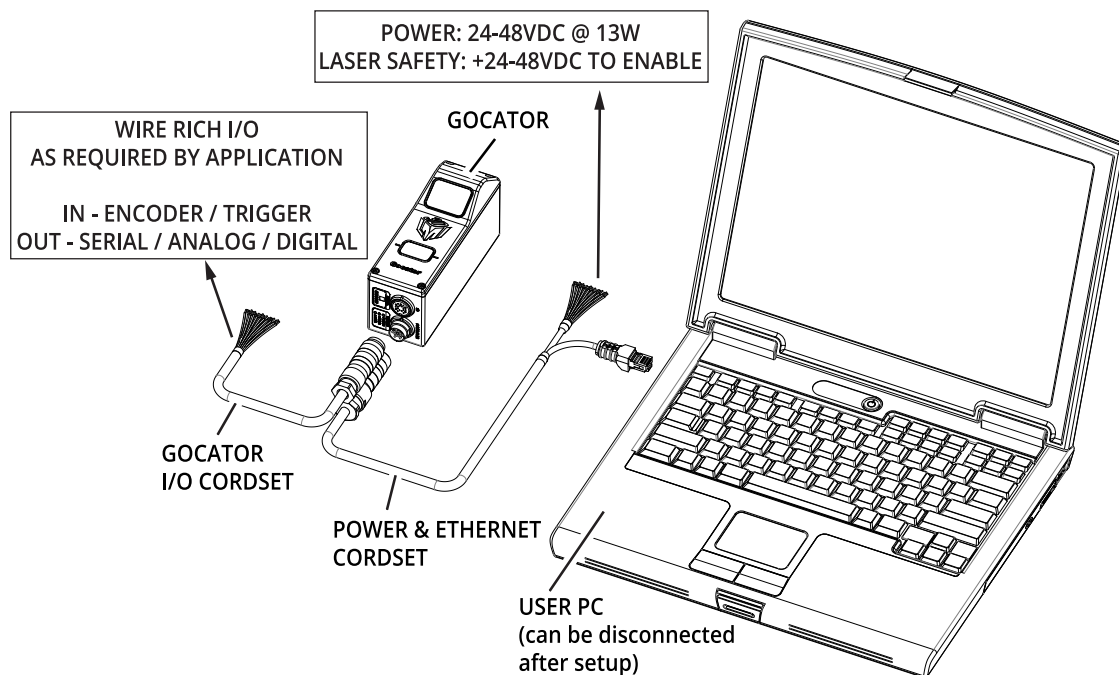

### Dual-Sensor System

In a dual-sensor system, two Gocator sensors work together to perform profiling and output the combined results. The controlling sensor is referred to as the *Main* sensor, and the other sensor is referred to as the *Buddy* sensor. Gocator's software recognizes three installation orientations: *None* (isolated), *Opposite* and *Wide*.

For the Gocator 2000 series sensors, the Master 200 must be used to connect two sensors in a dual-sensor system. Gocator 20x0 I/O cordsets are used to connect sensors to the Master 200. The Master 200 provides a single point of connection for system I/O and power. The Master 200 ensures that the scan timing is precisely synchronized across sensors. Sensors and client computers typically communicate via an Ethernet switch (minimum 100 Mbit/s).

### GOCATOR 2000 SERIES

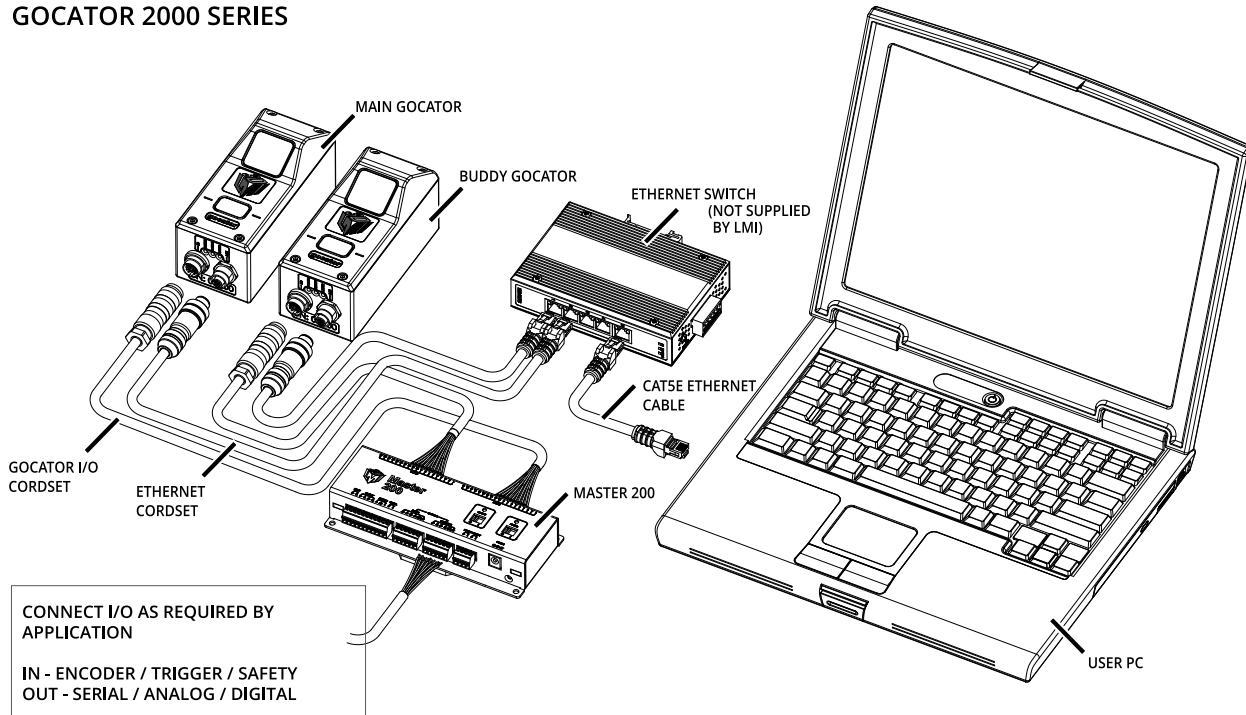

A Master 400/800/1200/2400 must be used to connect two sensors in a dual-sensor system. Gocator Power and Ethernet to Master cordsets are used to connect sensors to the Master.

## GOCATOR 2300 SERIES

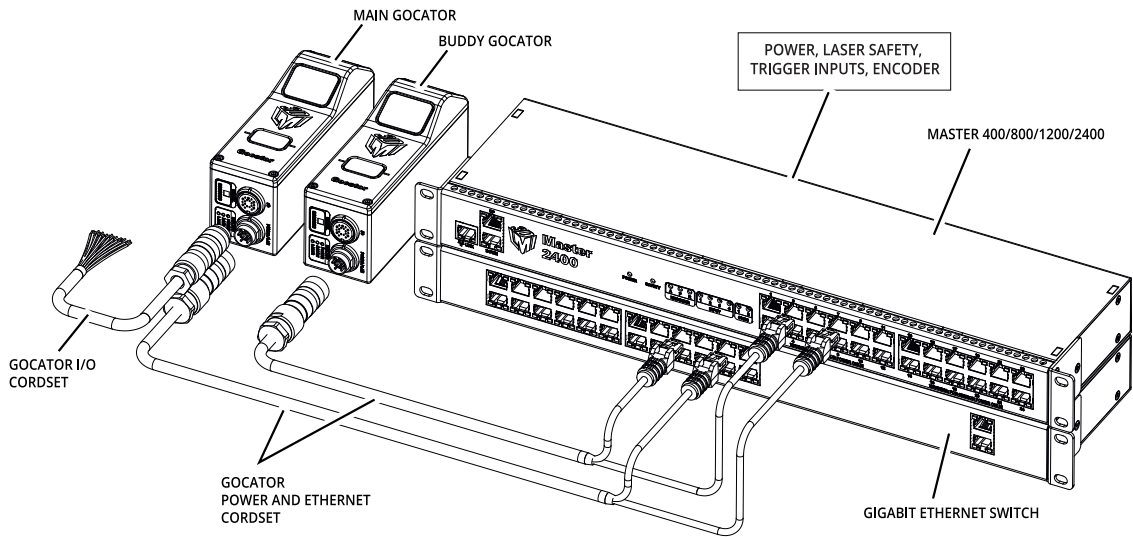

### Multi-Sensor System

Master 400/800/1200/2400 networking hardware can be used to connect two or more sensors into a multi-sensor system. Gocator Master cordsets are used to connect the sensors to a Master. The Master provides a single point of connection for power, safety, encoder, and digital inputs. A Master 400/800/1200/2400 can be used to ensure that the scan timing is precisely synchronized across sensors. Sensors and client computers communicate via an Ethernet switch (1 Gigabit/s recommended).

Unlike the Master 200, Master 400/800/1200/2400 networking hardware does not support digital, serial, or analog output.

## GOCATOR 2000 SERIES

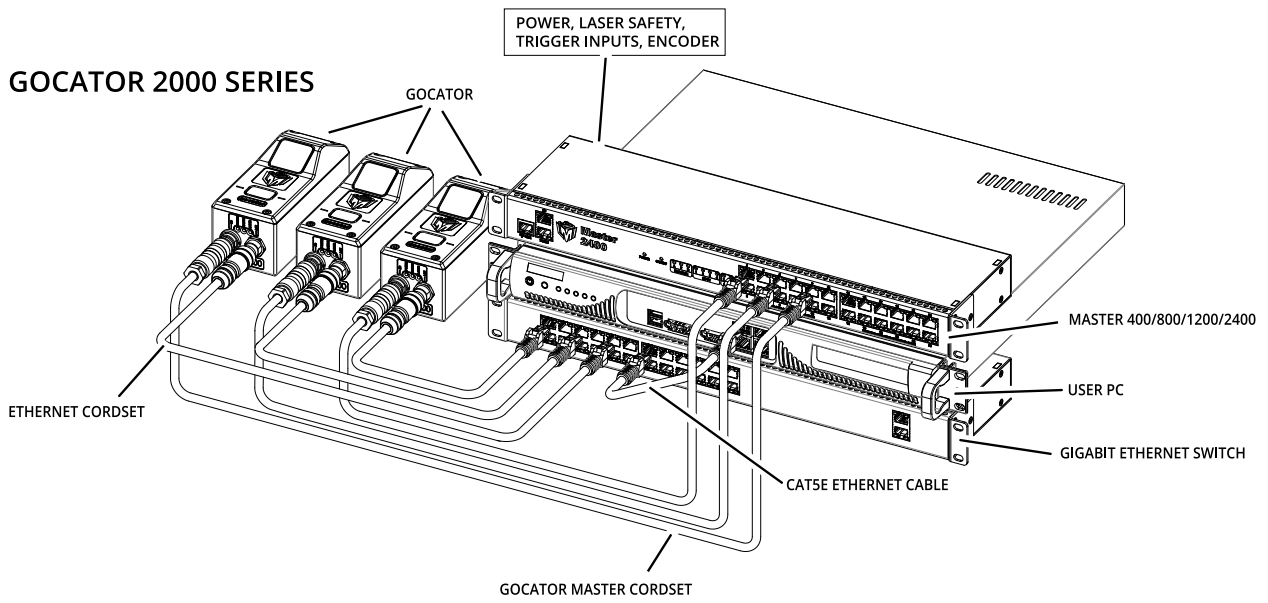

## GOCATOR 2300 SERIES

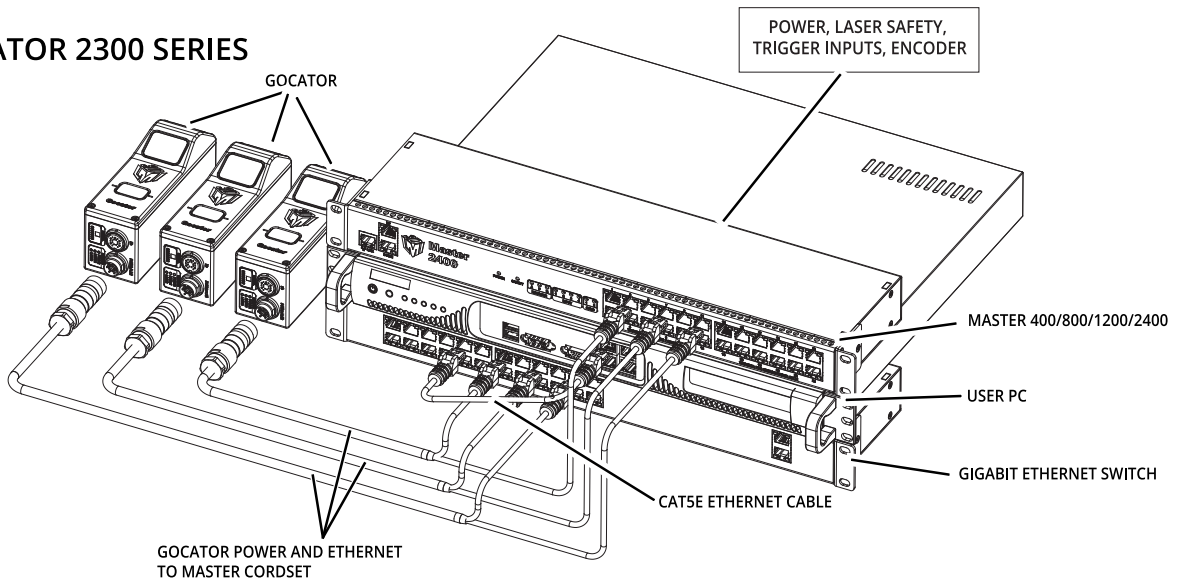

# Hardware Overview

The following sections describe Gocator and its associated hardware.

## Gocator 2000 Sensor

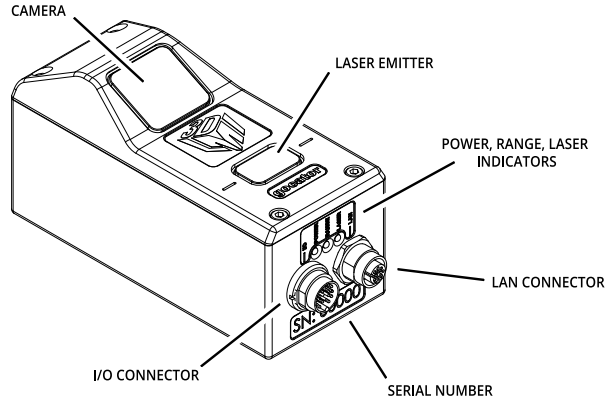

Item	Description
Camera	Observes laser light reflected from target surfaces.
Laser Emitter	Emits structured light for laser profiling.
I/O Connector	Accepts power and input/output signals.
LAN Connector	Connects to 100 Mbit/s Ethernet network.
Power Indicator	Illuminates when power is applied (blue).
Range Indicator	Illuminates when camera detects laser light and is within the target range (green).
Laser Indicator	Illuminates when laser safety input is active (amber).
Serial Number	Unique sensor serial number.

## Gocator 2300 & 2880 Sensor

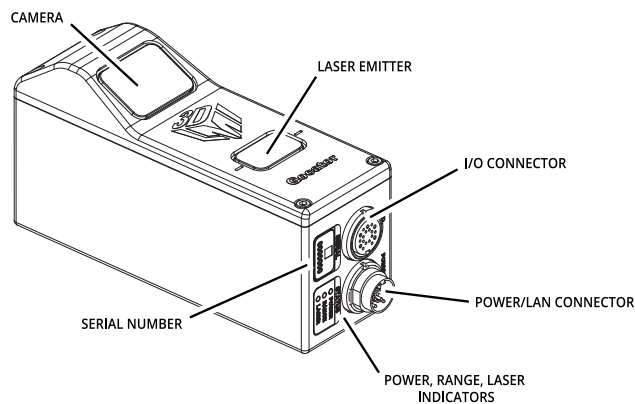

*Gocator 2330*

Item	Description
Camera	Observes laser light reflected from target surfaces.
Laser Emitter	Emits structured light for laser profiling.
I/O Connector	Accepts input and output signals.
Power / LAN Connector	Accepts power and laser safety signals and connects to 1000 Mbit/s Ethernet network.
Power Indicator	Illuminates when power is applied (blue).
Range Indicator	Illuminates when camera detects laser light and is within the target range (green).
Laser Indicator	Illuminates when laser safety input is active (amber).
Serial Number	Unique sensor serial number.

## Gocator 2000 Cordsets

Gocator 2000 sensors use three types of cordsets.

The Ethernet cordset is used for sensor communication via 100 Mbit/s Ethernet over a standard RJ45 connector.

The Gocator I/O cordset provides power and laser safety interlock to sensors. It also provides digital I/O connections, an encoder interface, RS-485 serial connection, and an analog output.

The Gocator Master cordset provides electrical connection between the sensor and a Master 400/800/1200/2400

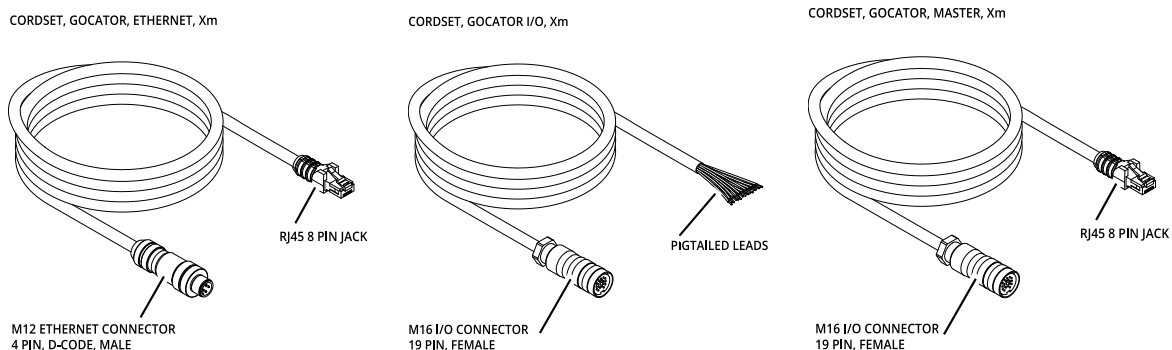

The maximum cordset length is 60 meters. See *Gocator 2000 I/O Connector* (page 350) for pinout details.

See *Parts and Accessories* (page 374) for cordset lengths and part numbers. Contact LMI for information on creating cordsets with customized lengths and connector orientations.

## Gocator 2300 & 2880 Cordsets

Gocator 2300 and 2880 sensors use two types of cordsets.

The Power & Ethernet cordset provides power, laser safety interlock to the sensor. It is also used for sensor communication via 1000 Mbit/s Ethernet with a standard RJ45 connector. The Master version of the Power & Ethernet cordset provides direct connection between the sensor and a Master 400/800/1200/2400.

The Gocator I/O cordset provides digital I/O connections, an encoder interface, RS-485 serial connection, and an analog output.

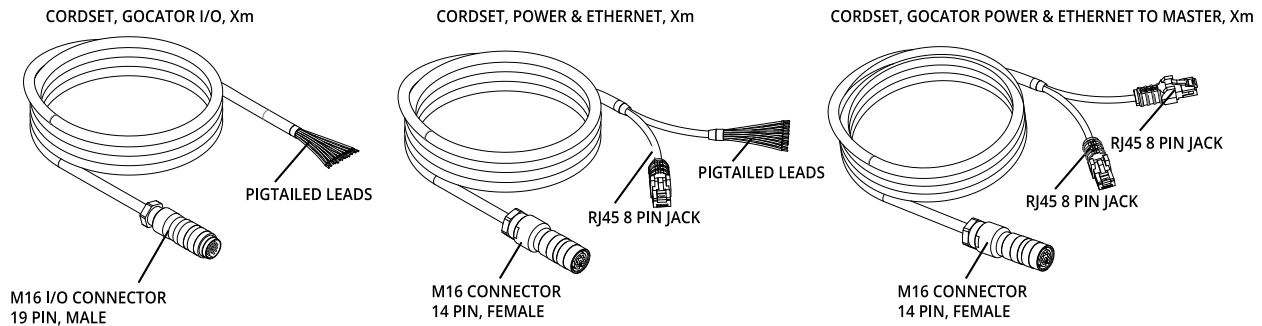

The maximum cordset length is 60 m. See *Gocator 2300 I/O Connector* (page 358) and *Gocator Power/LAN Connector* (page 356) for pinout details.

See *Parts and Accessories* (page 374) for cordset lengths and part numbers. Contact LMI for information on creating cordsets with customized lengths and connector orientations.

## Master 100

The Master 100 is used by the Gocator 2300 series for standalone system setup.

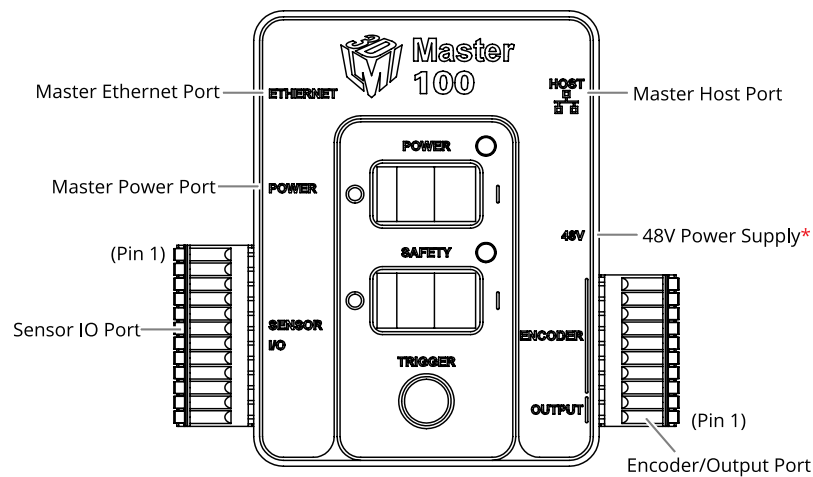

Item	Description
Master Ethernet Port	Connects to the RJ45 connector labeled Ethernet on the Power/LAN to Master cordset.
Master Power Port	Connects to the RJ45 connector labeled Power/Sync on the Power/LAN to Master cordset. Provides power and laser safety to the Gocator.
Sensor I/O Port	Connects to the Gocator I/O cordset.
Master Host Port	Connects to the host PC's Ethernet port.
Power	Accepts power (+48 V).
Power Switch	Toggles sensor power.
Laser Safety Switch	Toggles laser safety signal provided to the sensors [O= laser off, I= laser on].

Item	Description
Trigger	Signals a digital input trigger to the Gocator.
Encoder	Accepts encoder A, B and Z signals.
Digital Output	Provides digital output.

See *Master 100* (page 363) for pinout details.

## Master 200

The Master 200 supports standalone or dual-sensor setup. It is only used by the Gocator 2000 series.

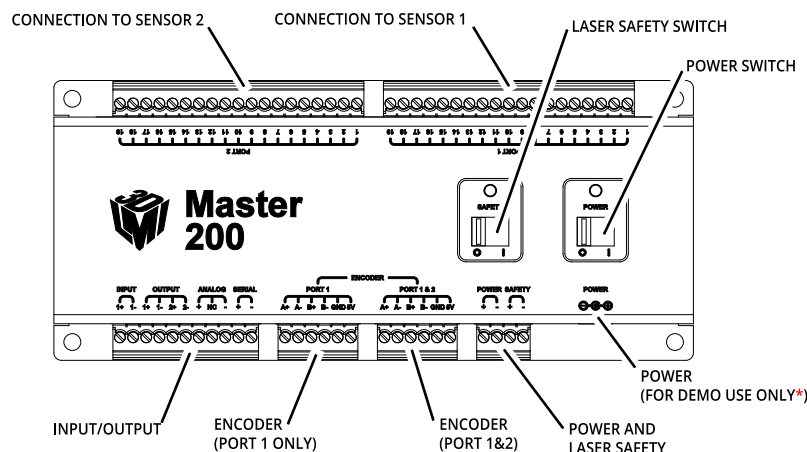

Item	Description
Connection to Sensor 2	Gocator I/O connection for Sensor 2 (Buddy sensor).
Connection to Sensor 1	Gocator I/O connection for Sensor 1 (Main sensor).
Laser Safety Switch	Toggles laser safety signal provided to the sensors [O= laser off, I= laser on].
Power Switch	Toggles sensor power.
Input/Output	Accepts digital input and provides digital output, serial output, and analog output.
Encoder (Port 1 only)	Accepts encoder for Standalone sensor operation (Main sensor only).
Encoder (Port 1 & 2)	Accepts encoder for Dual Sensor operation (Main and Buddy sensors).
Power and Laser Safety	Accepts power (+24 to +48 V at 10 Watts) and laser safety inputs.

See *Master 200* (page 365) for pinout details.

## Master 400/800

The Master 400 and the Master 800 allow you to connect more than two sensors. The Master 400 accepts four sensors, and the Master 800 accepts eight sensors.

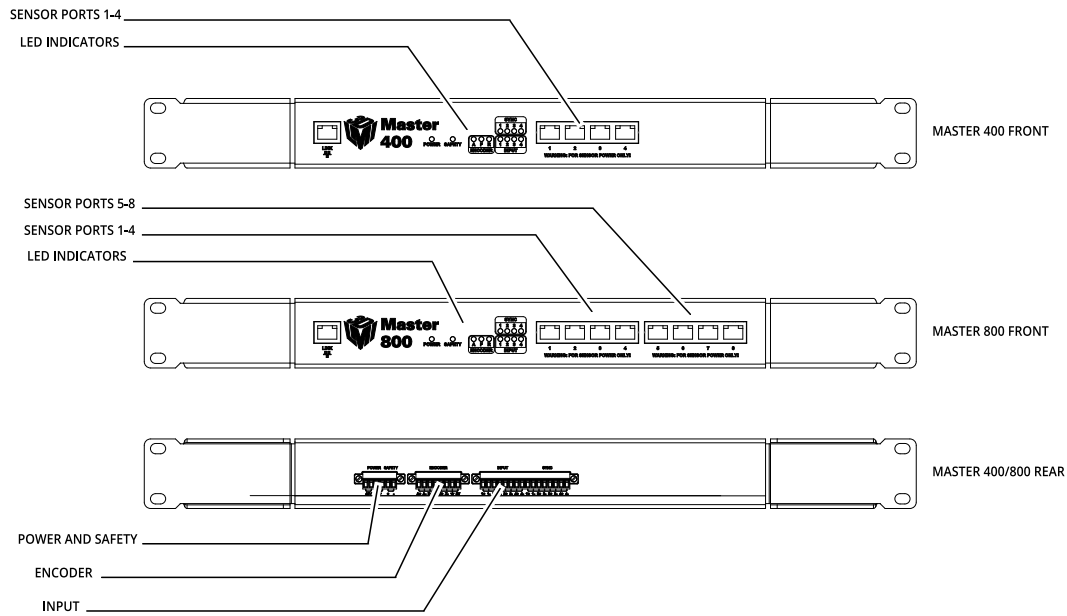

Item	Description
Sensor Ports	Master connection for Gocator sensors (no specific order required).
Ground Connection	Earth ground connection point.
Laser Safety	Laser safety connection.
Encoder	Accepts encoder signal.
Input	Accepts digital input.

See *Master 400/800* (page 368) for pinout details.

## Master 1200/2400

The Master 1200 and the Master 2400 allow you to connect more than two sensors. The Master 1200 accepts twelve sensors, and the Master 2400 accepts twenty-four sensors.

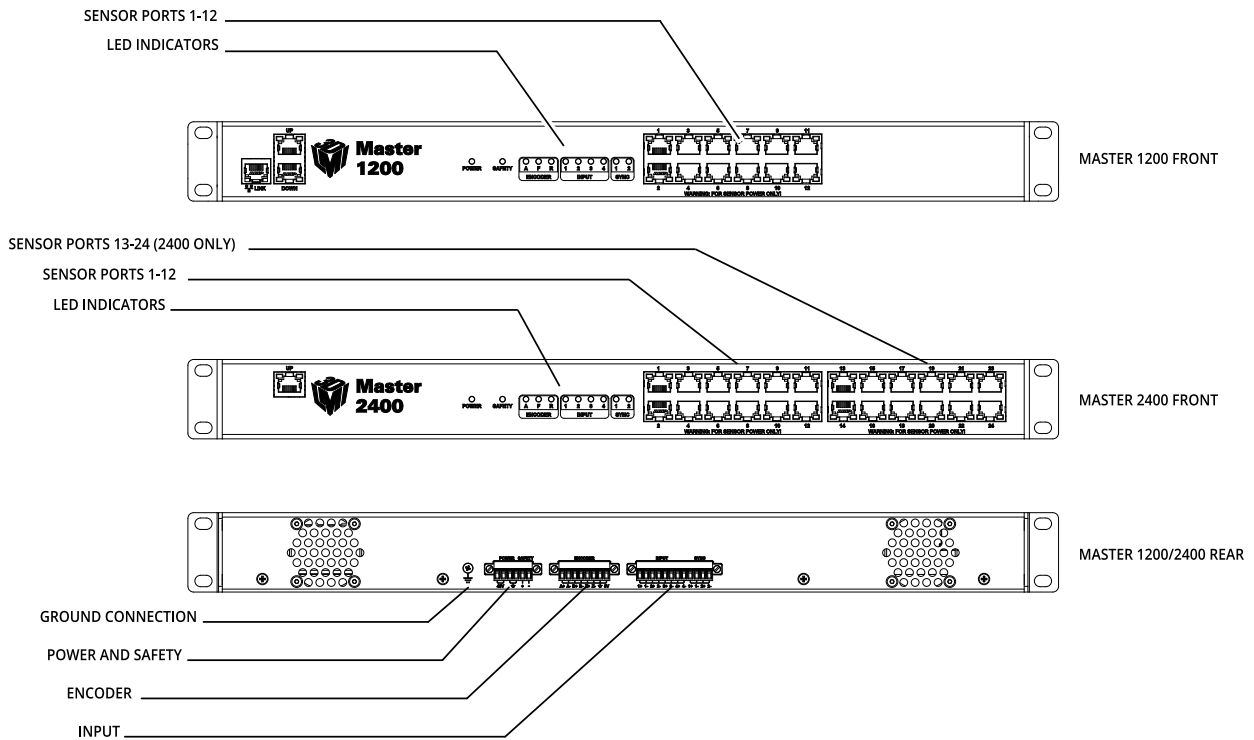

Item	Description
Sensor Ports	Master connection for Gocator sensors (no specific order required).
Ground Connection	Earth ground connection point.
Laser Safety	Laser safety connection.
Encoder	Accepts encoder signal.
Input	Accepts digital input.

See *Master 1200/2400* (page 371) for pinout details.

## Calibration Targets

Calibration targets are used for *alignment calibration* or *travel calibration*.

Calibration *disks* are typically used with systems containing a single sensor and can be ordered from LMI Technologies. When choosing a disk for your application, select the largest disk that fits entirely within the required field of view. See *Parts and Accessories* (page 374) for calibration disk part numbers.

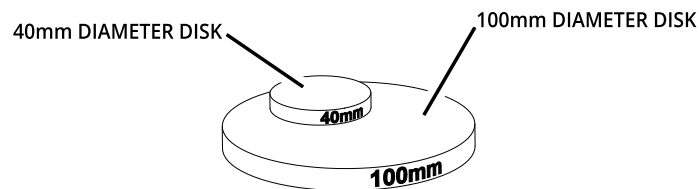

For wide, multi-sensor systems, calibration *bars* are required to match the length of the system by following the guidelines illustrated below. (LMI Technologies does not manufacture or sell calibration bars.)

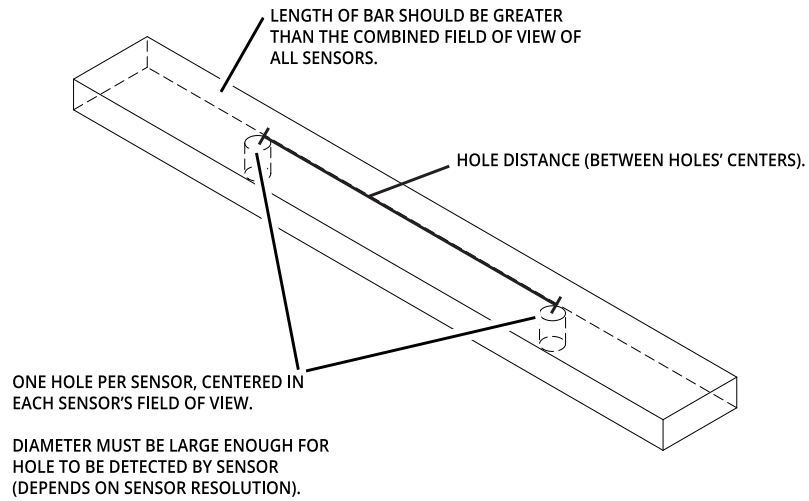

See *Calibration* (page 78) for more information on calibration procedures.

# Installation

The following sections provide grounding, mounting, and orientation information.

## Grounding - Gocator

Gocators should be grounded to the earth/chassis through their housings and through the grounding shield of the Power I/O cordset. Gocator sensors have been designed to provide adequate grounding through the use of M5 x 0.8 pitch mounting screws. Always check grounding with a multi-meter to ensure electrical continuity between the mounting frame and the Gocator's connectors.



The frame or electrical cabinet that the Gocator is mounted to must be connected to earth ground.

## Recommended Grounding Practices - Cordsets

If you need to minimize interference with other equipment, you can ground the Power & Ethernet or the Power & Ethernet to Master cordset (depending on which cordset you are using) by terminating the shield of the cordset before the split. The most effective grounding method is to use a 360-degree clamp.



The grounding practices described here only apply to Gocator 23xx sensors.

CORSET, POWER & ETHERNET, Xm

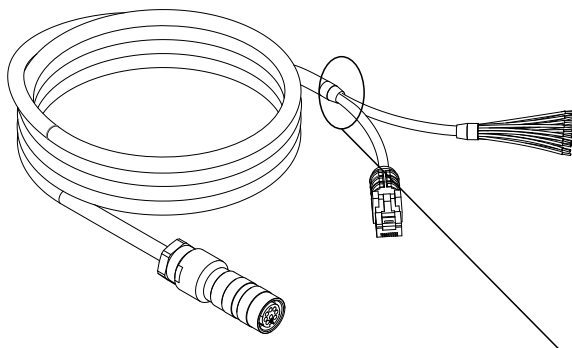

CORSET, GOCATOR POWER & ETHERNET TO MASTER, Xm

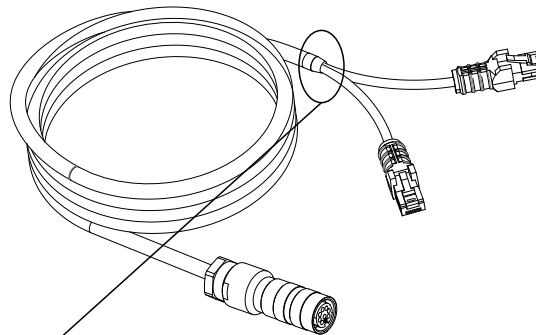

Attach the 360-degree clamp before the split

To terminate the cordset's shield:

1. Expose the cordset's braided shield by cutting the plastic jacket before the point where the cordset splits.



2. Install a 360-degree ground clamp.



## Grounding - Master 400/800/1200/2400

The mounting brackets of all Masters have been designed to provide adequate grounding through the use of star washers. Always check grounding with a multi-meter by ensuring electrical continuity between the mounting frame and RJ45 connectors on the front.



The frame or electrical cabinet that the Master is mounted to must be connected to earth ground.

## Mounting

Sensors should be mounted using four or six (depending on the model) M5 x 0.8 pitch screws of suitable length. The recommended thread engagement into the housing is 8 - 10 mm. Proper care should be taken in order to ensure that the internal threads are not damaged from cross-threading or improper insertion of screws.

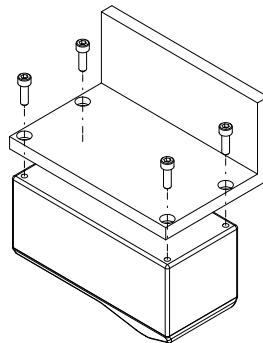

Sensors should not be installed near objects that might occlude a camera's view of the laser.

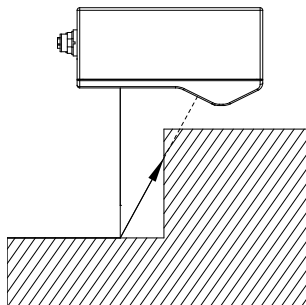

Sensors should not be installed near surfaces that might create unanticipated laser reflections.

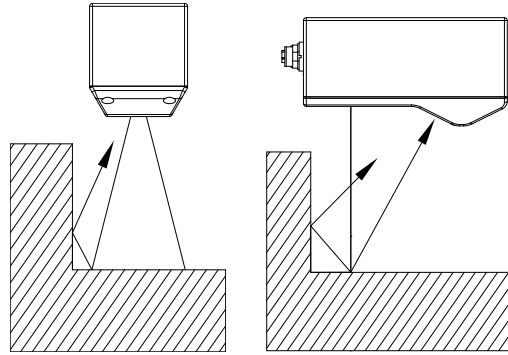

The sensor must be heat sunk through the frame it is mounted to. When a sensor is properly heat sunk, the difference between ambient temperature and the temperature reported in the sensor's health channel is less than 15° C.



Gocator sensors are high-accuracy devices. The temperature of all of its components must be in equilibrium. When the sensor is powered up, a warm-up time of at least one hour is required to reach a consistent spread of temperature within the sensor.

## Orientations

The examples below illustrate the possible mounting orientations for standalone and dual-sensor systems.

See *Dual-Sensor System Layout* (page 77) for more information on orientations.

### Standalone Orientations

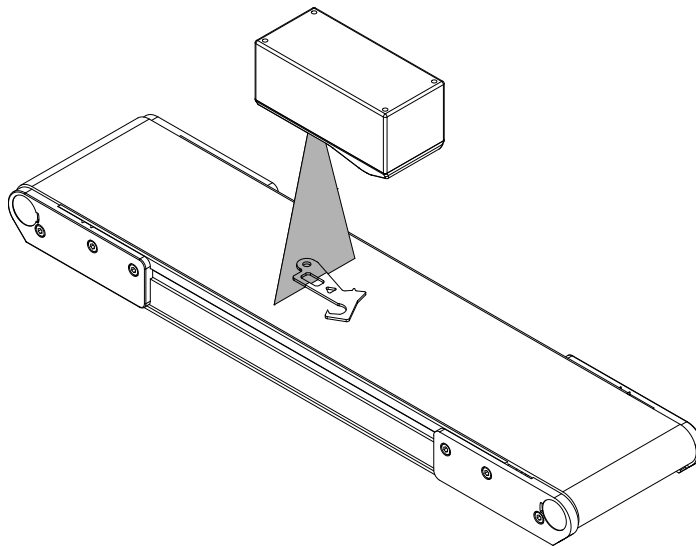

*Single sensor above conveyor*

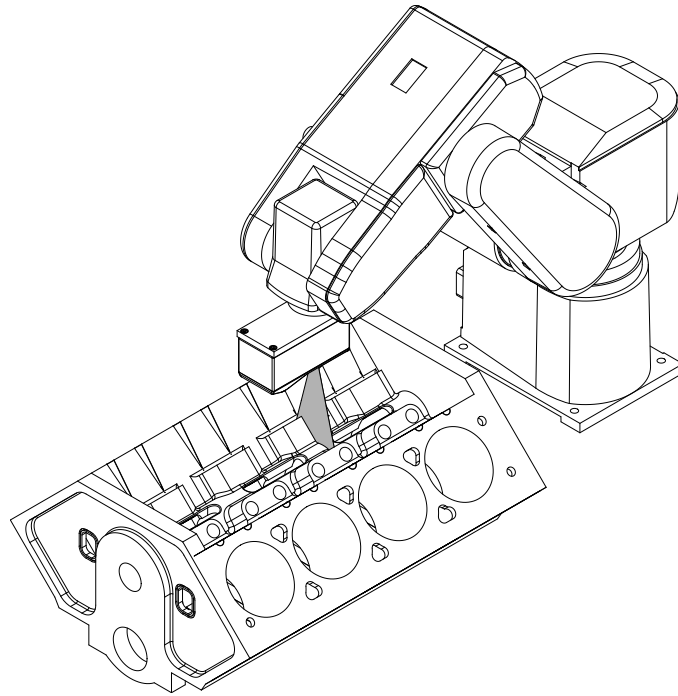

*Single sensor on robot arm*

**Dual-Sensor System Orientations:**

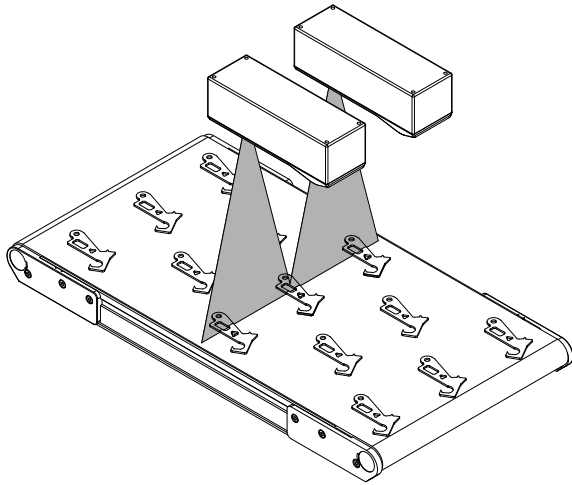

*Side-by-side for wide-area measurement (Wide)*

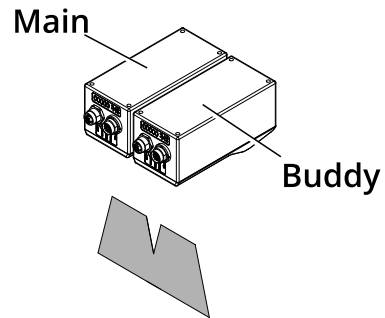

*Main must be on the left side (when looking into the connector of the Buddy (Wide))*

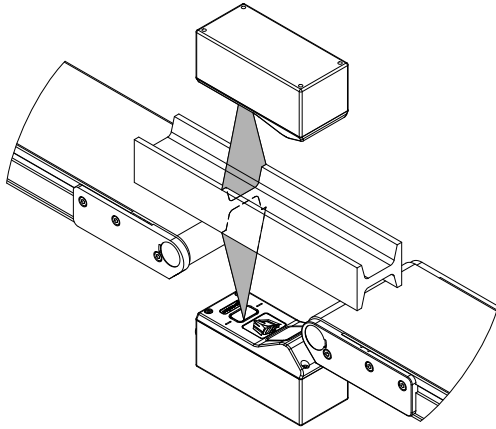

*Above/below for two-sided measurement (Opposite)*

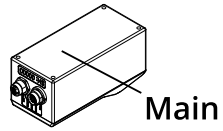

**Main**



**Buddy**

*Main must be on the top  
with Buddy on the bottom (Opposite)*

# Network Setup

The following sections provide procedures for client PC and Gocator network setup.

## Client Setup

Sensors are shipped with the following default network configuration:

Setting	Default
DHCP	Disabled
IP Address	192.168.1.10
Subnet Mask	255.255.255.0
Gateway	0.0.0.0



All Gocator sensors are configured to 192.168.1.10 as the default IP address. For a dual-sensor system, the Main and Buddy sensors must be assigned unique addresses before they can be used on the same network. Before proceeding, connect the Main and Buddy sensors one at a time (to avoid an address conflict) and use the steps in *Running a Dual-Sensor System* (page 37) to assign each sensor a unique address.

To connect to a sensor for the first time:

1. Connect cables and apply power.  
Sensor cabling is illustrated in *System Overview* (page 17).

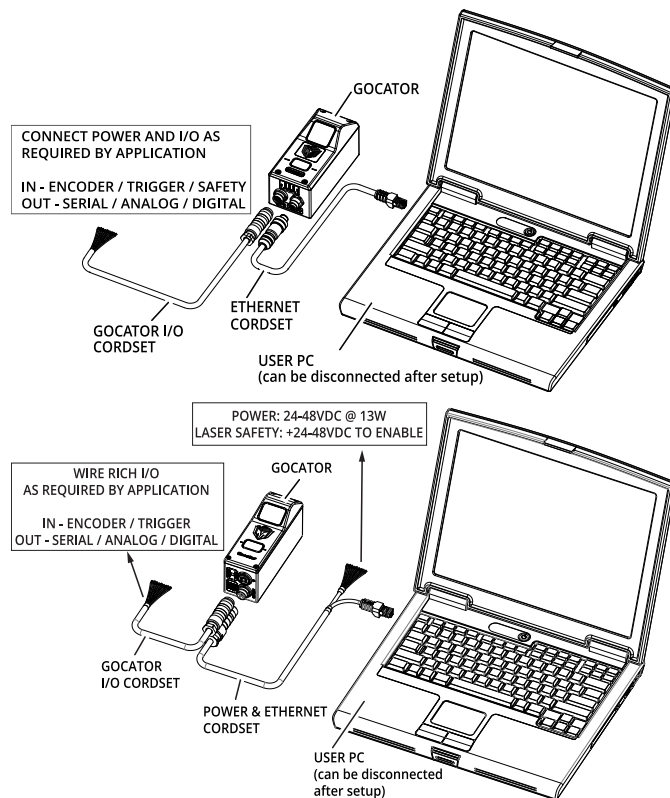

2. Change the client PC's network settings.

*Windows 7*

- a. Open the Control Panel, select **Network and Sharing Center**, and then click **Change Adapter Settings**.
- b. Right-click the network connection you want to modify, and then click **Properties**.
- c. On the **Networking** tab, click **Internet Protocol Version 4 (TCP/IPv4)**, and then click **Properties**.
- d. Select the **Use the following IP address** option.
- e. Enter IP Address "192.168.1.5" and Subnet Mask "255.255.255.0", then click **OK**.

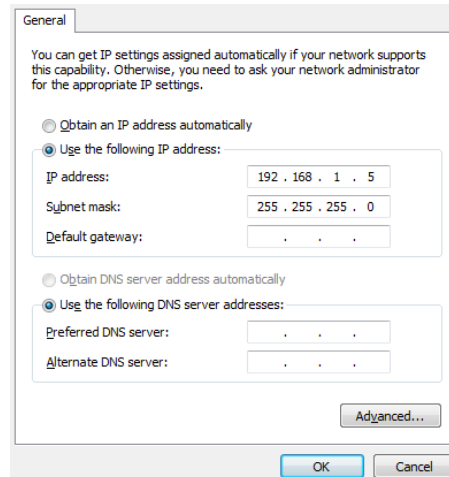

*Mac OS X v10.6*

- a. Open the Network pane in **System Preferences** and select **Ethernet**.
- b. Set **Configure** to **Manually**.
- c. Enter IP Address "192.168.1.5" and Subnet Mask "255.255.255.0", then click **Apply**.

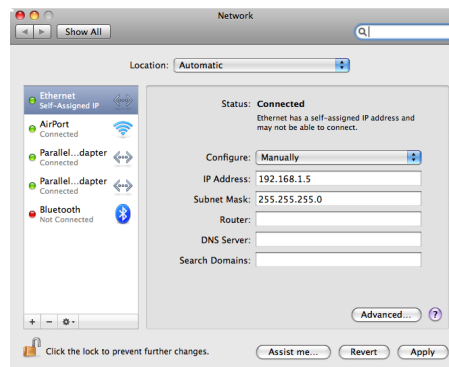

 See *Troubleshooting* (page 320) if you experience any problems while attempting to establish a connection to the sensor.

## Gocator Setup

The Gocator is shipped with a default configuration that will produce laser profiles on most targets.

The following sections walk you through the steps required to set up a standalone sensor system and a dual-sensor system for operations. After you have completed the setup, you can perform laser profiling to verify basic sensor operation.

### Running a Standalone Sensor System

To configure a standalone sensor system:

1. Power up the sensor.  
The power indicator (blue) should turn on immediately.

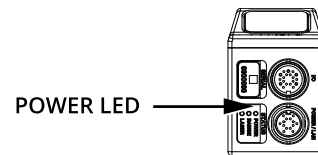
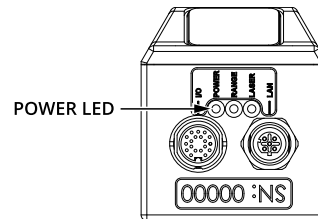

2. Enter the sensor's IP address (192.168.1.10) in a web browser.
3. Log in as Administrator with no password.  
The interface display language can be changed using the language option. After selecting the language, the browser will refresh and the web interface will display in the selected language.
4. Select the **Connection** page.

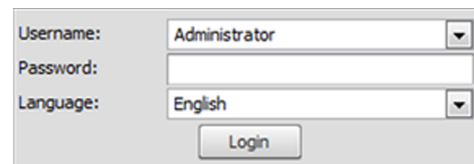

- Choose a **Connect To** setting.  
The **Connect To** setting specifies whether the sensor system is standalone or connected to a Master 200/400/800/1200/2400. For single-sensor operations, select **Standalone** or **Master 200**.

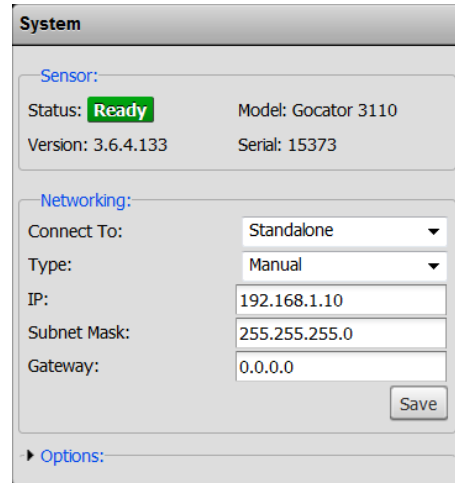

- Ensure that the **Data Source** selector is showing LIVE.



- Ensure that the Laser Safety Switch is enabled or the Laser Safety input is high.
- Select the **Setup** page.
- Press the **Start** button to start the sensor.  
The **Start** button is used to run sensors continuously, whereas the **Snapshot** button is used to trigger a single capture.

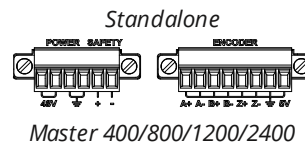
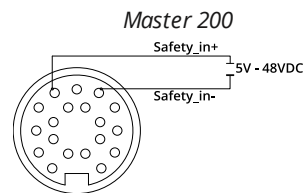
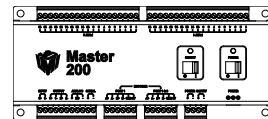

- Move a target into the laser plane.  
If a target object is within the sensor's measurement range, the data viewer will display the shape of the target, and the sensor's range indicator will illuminate. If you cannot see the laser, or if a profile is not displayed in the Data Viewer, see *Troubleshooting* (page 320).

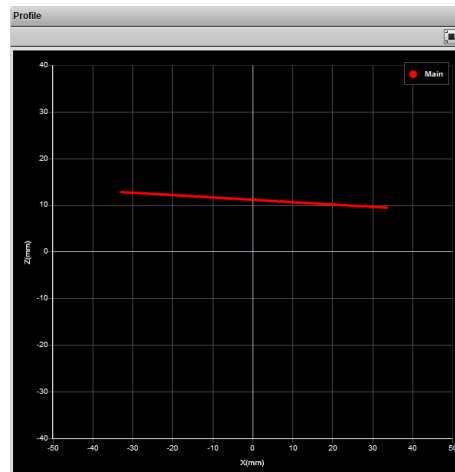

- Press the **Stop** button.  
The laser should turn off.



## Running a Dual-Sensor System

All sensors are shipped with a default IP address of 192.168.1.10. Ethernet networks require a unique IP address for each device, so you must set up a unique address for each sensor.

 If Master 200 is used and an encoder input is required, the encoder signals must be connected to the Encoder (port 1 & 2). See *Master 200* (page 365) for more details.

To configure a dual-sensor system:

- Turn off the sensors and unplug the Ethernet network connection of the Main sensor.  
All sensors are shipped with a default IP address of 192.168.1.10. Ethernet networks require a unique IP address for each device. Skip step 1 to 3 if the Buddy sensor's IP address is already set up with a unique address.

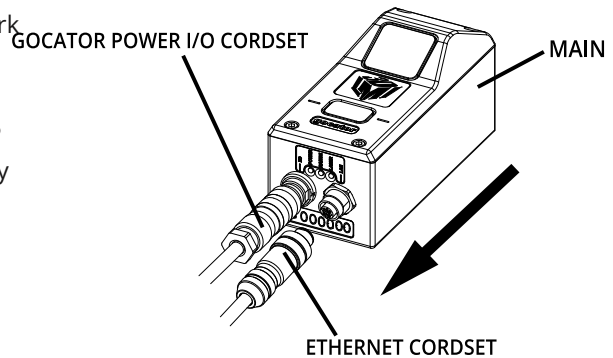

- Power up the Buddy sensor.  
The power LED (blue) of the Buddy sensor should turn on immediately.

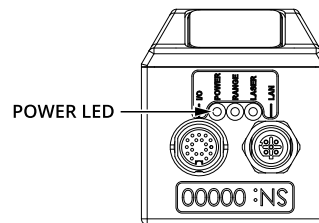

- Enter the sensor's IP address 192.168.1.10 in a web browser.  
This will log into the Buddy sensor.
- Log in as Administrator with no password.



Username:

Password:

Language:

- Select the **Connection** Page.



- Modify the IP address to 192.168.1.11 in the **Network** settings and click the **Save** button.

When you click the **Save** button, you will be prompted to confirm your selection.

Connect To: Master 400  
 Type: Manual  
 IP: 192.168.1.11  
 Subnet Mask: 255.255.255.0  
 Gateway: 0.0.0.0  
 Save

- Turn off the sensors, re-connect the Main sensor's Ethernet connection and power-cycle the sensors. After changing network configuration, the sensors must be reset or power-cycled before the change will take effect.

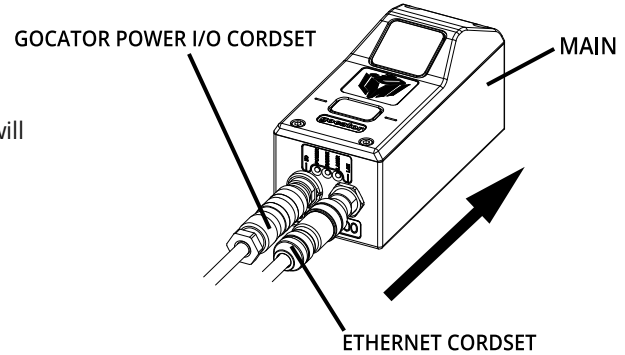

- Enter the sensor's IP address 192.168.1.10 in a web browser.

This will log into the Main sensor.



- Log in as Administrator with no password.

The interface display language can be changed using the language option. After selecting the language, the browser will refresh and the web interface will display in the selected language.

Username: Administrator  
 Password:   
 Language: English  
 Login

- Select the **Connection** page.



- Choose a **Connect To** setting.

The **Connect To** setting specifies whether the sensor system is standalone or connected to a Master 200 or a Master 400/800/1200/2400. For dual-sensor operations, select **Master 200** or **Master 400/800/1200/2400**.

Connect To: Master 400  
 Type: Manual  
 IP: 192.168.1.10  
 Subnet Mask: 255.255.255.0  
 Gateway: 0.0.0.0  
 Save

- Go to **Connection** page and select the **Available Sensors** panel.

The serial number of the Buddy sensor is listed in the Available Sensors panel.

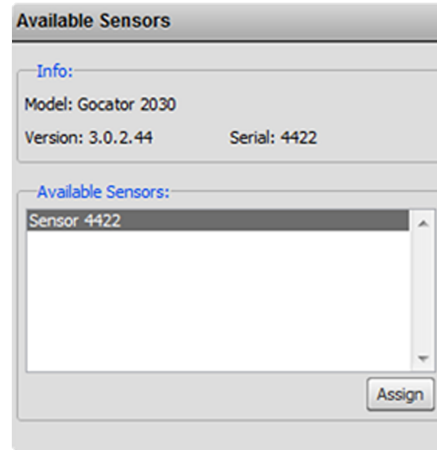

- Select the Buddy sensor. Click the **Assign** button.

The Buddy sensor will be assigned to the Main sensor and its status will be updated in the System panel. The firmware on Main and Buddy sensors must be the same for Buddy assignment to be successful. If the firmware is different, connect the Main and Buddy sensor one at a time and follow the steps in *Firmware Upgrade (page 60)* to upgrade the sensors.

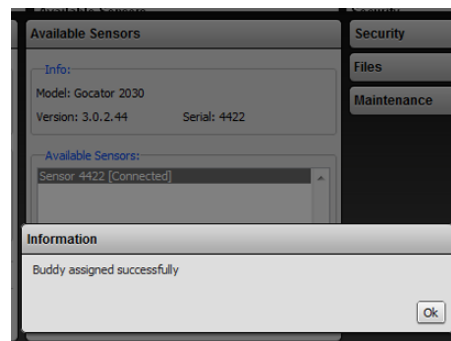

- Ensure that the **Data Source** selector is showing LIVE.



- Ensure that the Laser Safety Switch is enabled or the Laser Safety input is high.

- Select the **Setup** page.

- Press the **Start** button to start the sensors.

The **Start** button is used to run sensors continuously, while the Snapshot button is used to trigger a single profile.

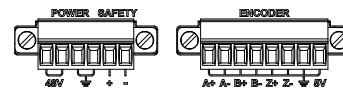

Master 400/800/1200/2400 (for Gocator 2300)

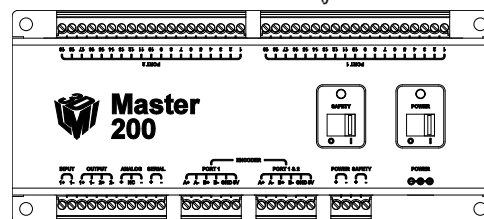

Master 200 (for Gocator 2000)

18. Move a target into the laser plane.

If a target object is within the sensor's measurement range, the data viewer will display the shape of the target, and the sensor's range indicator will illuminate. If you cannot see the laser, or if a profile is not displayed in the Data Viewer, see *Troubleshooting* (page 320).

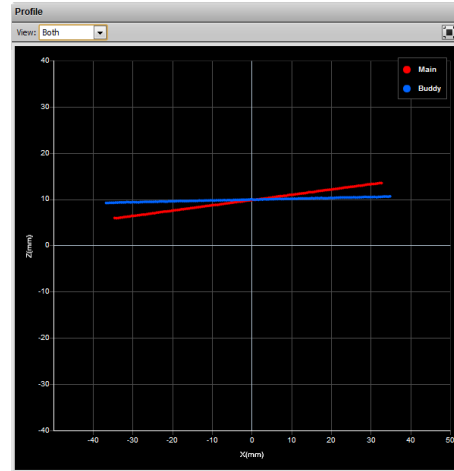

19. Press the **Stop** button.

The laser should turn off.



## Next Steps

After you complete the steps in this section, the Gocator measurement system is ready to be configured for an application using the software interface. The interface is explained in the following sections:

### Connection and Maintenance (page 54)

Sets up the sensor connections, networking and performs maintenance tasks.

### Setup and Calibration (page 62)

Fine-tunes laser profiling for an application.

### Measurement (page 94)

Programs measurements on sensors that are equipped with measurement tools.

### Output (page 157)

Profile data, measurements, and Pass/Fail results can be transmitted to external devices for process control or data analysis.

### Dashboard (page 168)

Provides real-time monitoring of its health and measurement results.

### Toolbar (page 47)

Controls system operation, record and playback data, and manages sensor configurations.

# Theory of Operation

The following sections describe the theory of operation of Gocator sensors.

## 3D Acquisition

### Principle of 3D Acquisition

The Gocator 2000 and 2300 series sensors are line profiler sensors, meaning that they capture a single 3D profile for each camera exposure. The sensor projects a laser line onto the target. The sensor's camera views the laser from an angle, and captures the reflection of the light off the target. Because of this triangulation angle, the laser line appears in different positions on the camera depending on the 3D shape of the target. Gocator sensors are always pre-calibrated to deliver 3D data in engineering units throughout the specified measurement range.

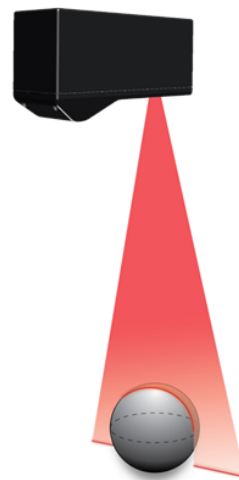

Target objects are typically moved under the sensor on a transportation mechanism, such as a conveyor belt. The sensor captures a series of 3D slices, building up the full scan of the object. Sensor speed and required exposure time to measure the target are typically critical factors in applications with line profiler sensors.

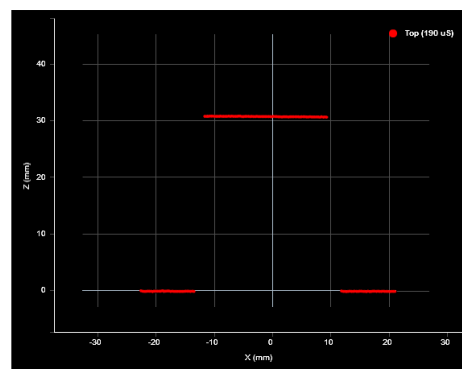
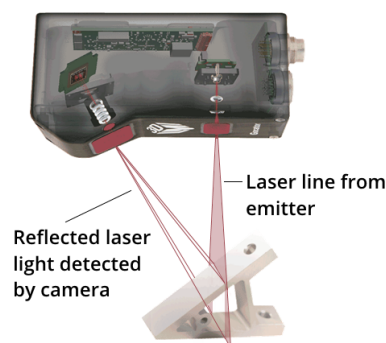

Resulting laser profile

## Resolution and Accuracy

### X Resolution

X resolution is the horizontal distance between each measurement point along the laser line. This specification is essentially based on the number of camera columns used to cover the field of view (FOV) at a particular measurement range .

Since the FOV is trapezoidal, the distance between points is closer at the near range than at the far range. This is reflected in the Gocator data sheet as the two numbers quoted for X Resolution.

X Resolution is important for how accurately the width of a target can be measured.

NOTE: When the Gocator runs in Profile Mode, the 3D data is resampled to an X interval that is different from the raw camera resolution.

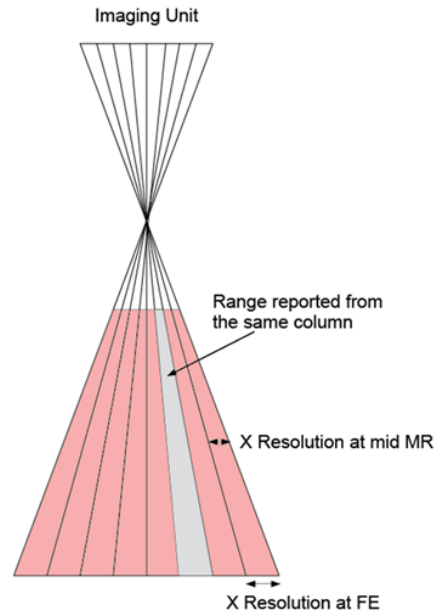

### Z Resolution

Z resolution is the variability of the height measurement, in each individual 3D point, with the target at a fixed position. This variability is caused by camera imager and sensor electronics.

Like X resolution, the Z resolution is better at the close range and worse at the far range. This is reflected in the Gocator data sheet as the two numbers quoted for Z resolution.

Z Resolution gives an indication of the smallest detectable height difference.



## Z Linearity

Z Linearity is the difference between the actual distance to the target and the measured distance to the target, throughout the measurement range.

Z Linearity is expressed in the Gocator data sheet as a percentage of the total measurement range.

Z Linearity gives an indication of the sensor's ability to measure absolute distance

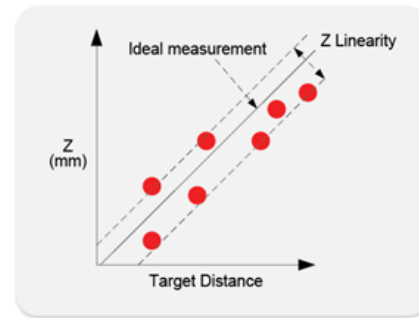

# Profile Output

Gocator measures the height of the object calculated from laser triangulation. The Gocator reports a series of ranges along the laser line, with each range representing the distance from the sensor's origin plane. Each range contains a height and a position in the sensor's field of view.

## Coordinate Systems

Range data is reported in sensor or system coordinates depending on the alignment calibration state. The coordinate systems are described below.

### Sensor Coordinates

Before alignment calibration, individual sensors use the coordinate system shown here. The Z axis represents the sensor's measurement range (MR), with the values increasing towards the sensor. The X axis represents the sensor's field of view (FOV). The origin is at the center of the MR and FOV. In Part data, the Y axis represents the relative position of the part in the direction of travel. Y position increases as the object moves forward (increasing encoder position).

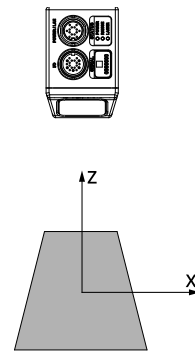

### System Coordinates

Alignment calibration or travel calibration can be used to establish a common coordinate system for the Main and Buddy sensors. Calibration determines the adjustments to X, Z, and tilt (rotation in the X-Z plane) required to align the data from each sensor. System coordinates are aligned such that the system X axis is parallel to the calibration target surface. The system Z origin is set to the base of the calibration target. The tilt angle is positive when rotating from the X to the Z axis. Similar to the sensor coordinates, Y positions increase when the encoder increases. For Wide and Opposite layouts, profiles and measurements from the Main and Buddy sensors are expressed in a unified coordinate system. Isolated layouts express results using a separate coordinate system for each sensor.

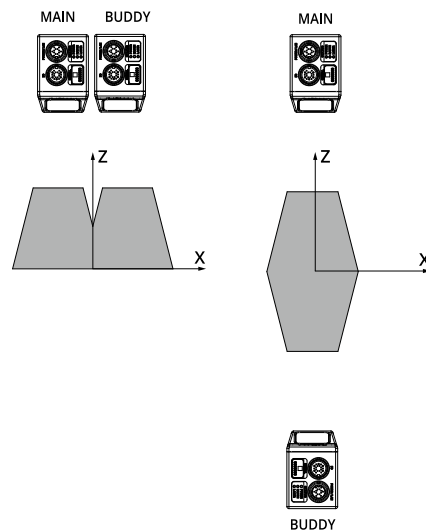

## Resampled and Raw Profile Format

Profile data produced by Profile or Part mode are processed differently than data produced by Raw Mode. In Profile or Part mode, the ranges are resampled to an even interval along the laser line (X axis). The resampling divides the X axis into fixed-size "bins" at even intervals. Profile points that fall into the same bin will be combined into a single range value (Z). The size of the resampling interval can be configured in the see *Filters Panel* (page 82).

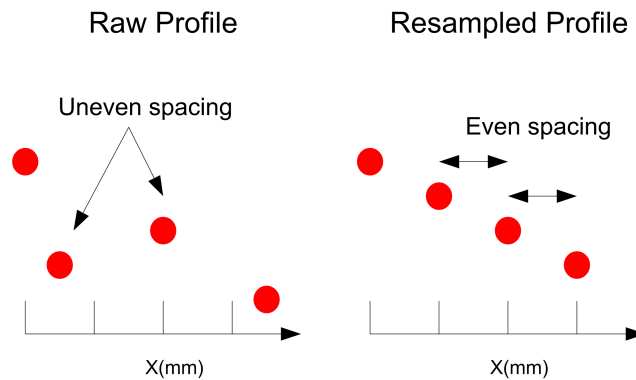

In the Ethernet data channel, only the range values (Z) are reported and the X positions can be reconstructed through the array index at the receiving end (the client).

Resampling reduces the complexity for downstream algorithms to process the profile data from the Gocator, but at the cost of higher processing load on the sensor's CPU.

In contrast, Raw mode outputs unprocessed range data. Ranges are reported in (X, Z) coordinate pairs, freeing up processing resources in the Gocator, but typically requiring more complicated processing on the client side.

All built-in measurement tools in the Gocator operate on resampled data in Profile or Part mode.

# Gocator Web Interface

The following sections describe the Gocator web interface.

## User Interface Overview

Gocator sensors are configured by connecting to a *Main* sensor with a web browser. The Gocator web interface is illustrated below.



Element	Description
1 Connection page	Contains settings for network configuration and maintenance. See <i>Connection and Maintenance</i> (page 54).
2 Setup page	Contains settings for trigger source, exposure, and performing calibration steps. See <i>Setup and Calibration</i> (page 62).
3 Measurement page	Contains built-in measurement tools and their settings. See <i>Measurement</i> (page 94).
4 Output page	Contains settings for configuring output protocols used to communicate measurements to external devices. See <i>Output</i> (page 157).

Element	Description
5	Dashboard Provides monitoring of measurement statistics and sensor health. See <i>Dashboard</i> (page 168).
6	Metrics panel Summarizes important performance statistics. See <i>Metrics Panel</i> (page 52).
7	Help Provides online help resources (including user manual), firmware updates, and SDK.
8	Toolbar Controls sensor operation, manages configurations, and replays recorded measurement data. See <i>Toolbar</i> (below).
9	Configuration area Provides controls to configure profiling and measurement parameters.
10	Data viewer Displays sensor data, tool setup controls, and measurements. See <i>Data Viewer</i> on page 86 for its use when the Setup page is active and on page 97 for its use when the Measurement page is active.

## Common Elements

### Toolbar

The toolbar is the central place for performing common operations. This section explains how to use the toolbar to manage the sensor configurations and to operate the sensor.

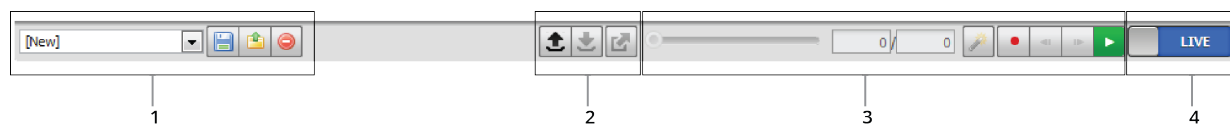

Element	Description
1	Configuration Controls Use the configuration controls to manage sensor settings.
2	Recorded Data Controls Use the recorded data controls to download, export, and upload recorded data.
3	Sensor Operation / Replay Control Use the sensor operation controls to start sensors, enable recording, and control recorded data.
4	Data Source Use the <b>Data Source</b> button to switch the sensor between live and replay mode.

### Saving and Loading Settings

When you change sensor settings using the Gocator web interface, some changes are saved automatically, while other changes are temporary until you take action to save them. The following table lists the types of information that can be saved in a sensor.

Setting Type	Behavior
Network Address	Network address changes are saved when you click the <b>Save</b> button in the <b>Main</b> panel on the <b>Connections</b> page. The sensor must be reset before changes take effect.
Configuration	Most of the settings that can be changed in the Gocator's web interface, such as those shown on the <b>Setup</b> , <b>Measurement</b> , and <b>Output</b> pages, are temporary until saved in a configuration file. Each sensor can have multiple configuration files. If there is a

Setting Type	Behavior
	configuration file that is designated as the default, it will be loaded automatically when the sensor is reset.
Calibration	<p>Calibration files are saved automatically at the end of the calibration procedure; see page 251 for a description of this type of file.)</p> <p>The sensor contains a global calibration file that is not visible in the file manager. This file is automatically loaded when the sensor is reset.</p> <p>Configurations can be associated with specific calibration files, which are created by selecting <b>Current Configuration</b> as the source when calibrating the Gocator; see <i>Calibration</i> (page 78) for more information on calibrating sensors. These files are visible in the file manager. Associated files have the same file name (but a different extension). If there is a configuration file that is designated as default and it has an associated calibration file, that calibration will be loaded automatically when the sensor is reset.</p>
Profile Templates	Profile templates are temporary until saved. (See <i>Profile Fixturing</i> (page 95).) Each sensor can have multiple profile template files. If there is a template file that is designated as the default, it is loaded automatically when the sensor is reset.

Each sensor can have only one global calibration file. But a sensor can contain many calibrations associated with specific configurations, as well as many template files. The number of files is limited only by the sensor's flash storage capacity. The Gocator's web interface provides toolbar commands to load and save these files together as a *bundle*.

 Gocator can be set up to operate with a global calibration or with a calibration associated with a specific configuration (see *Calibration* (page 78)). An associated calibration file is only included in the file bundle if **Current Configuration** is currently selected as the calibration source.

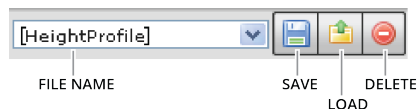

The **File Name** drop-down list shows the list of file bundles stored in the sensor. The configuration that is currently loaded is listed at the top. The name will be marked with an asterisk if the live configuration is different from the loaded configuration to indicate unsaved changes.

*To save a new bundle of files:*

1. Select **[New]** in the **File Name** drop-down list.
2. Enter a name for the file bundle.
3. Press the **Enter** key or click the **Save** button.  
The files are saved to flash memory using the name provided. The saved files are set as the defaults to be loaded automatically when the sensor is reset.

*To overwrite an existing bundle of files:*

1. Select an existing file name in the **File Name** drop-down list.

2. Click the **Save** button.

A dialog is displayed to confirm overwriting the existing files. The files are saved to flash memory using the selected name. The saved files are set as the defaults to be loaded automatically when the sensor is reset.

#### *To load a bundle of files:*

1. Select an existing file name in the **File Name** drop-down list.

2. Click the **Load** button.

The files are loaded from flash memory, and unsaved changes to current settings are overwritten.

#### *To delete a bundle of files:*

1. Select an existing file name in the **File Name** drop-down list.

2. Click the **Delete** button.

The files are deleted from the flash memory.

Managing individual files is described in *Files Panel (page 58)*.

## **Managing Multiple Settings**

A Gocator can store multiple bundles of configurations, calibrations, and templates. The ability to use multiple bundles is useful when a Gocator is used for different purposes, or with different constraints during separate production runs (for example, width decision constraints might be loose during one production run and tight during another depending on the desired grade of the part).

#### *To manage a system with multiple configurations:*

1. Configure settings for the first target object.

Use the **Setup**, **Measurement**, and **Output** pages to configure settings for the first target.

2. Save the first configuration.

Enter a file name and click the **Save** button to save the configuration.

3. Configure settings for the second target object.

Use the **Setup**, **Measurement**, and **Output** pages to configure settings for the second target.

4. Save the second configuration.

Enter a file name (different from the one used for the first configuration) and click the **Save** button to save the configuration.

5. When production changes, load the desired configuration.

Select the desired configuration and click the **Load** button. The configuration is loaded and the sensors will be ready for production.

## Recording, Playback, and Measurement Simulation

Gocator sensors have the ability to record and replay data, and also to simulate measurement tools on recorded data. This feature is most often used for troubleshooting and fine-tuning measurements, but can also be helpful during setup.

Recording and playback are controlled by using commands in the toolbar.

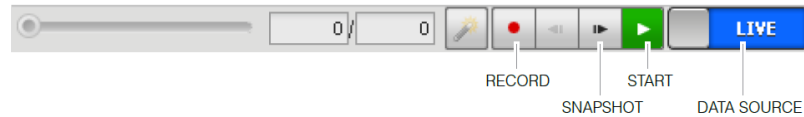

*Recording and Playback commands when Data Source is Live*



*Recording and Playback commands when Data Source is Replay*

*To record live data:*

1. Toggle the **Data Source** to **Live**.
2. Press the *Record* button.  
When the **Data Source** is set to **Live** and recording is enabled, the sensor will store the most recent data as it runs. Remember to disable recording if you no longer wish to record live data (press the **Record** button again to disable recording).
3. Press the **Snapshot** button or **Start** button.  
Snapshot will cause a single frame to be recorded. The **Start** button will run the sensor continuously and all frames will be recorded, up to available memory. When the memory limit is reached, the oldest data will be discarded. New data is appended to the record buffer unless the configuration has changed.



Newly recorded data is appended to existing replay data unless the sensor configuration has been modified.

*To replay recorded data:*

1. Toggle the *Data Source* to *Replay*.
2. Use the **Replay Slider**, **Step Forward**, **Step Back**, or **Play** buttons to review data.  
The **Step** buttons advance / reverse the current replay location by a single frame.  
The **Play** button advances the replay location continuously, animating the playback.  
The **Pause** button (replaces the **Play** button while playing) can be used to pause the replay at a particular location.  
The **Replay** slider (or **Replay Position** box) can be used to navigate to a specific replay frame.

*To simulate measurements on recorded data:*

1. Toggle the **Data Source** to **Replay**.
2. Go to the **Measurement** page.  
Modify settings for existing measurements, add new measurement tools, or delete measurement tools as desired.
3. Use the **Replay Slider**, **Step Forward**, **Step Back**, or **Play** button to simulate measurements.  
Step or play through recorded data to execute the measurement tools on the recording.  
Individual measurement values can be viewed directly in the data viewer. Statistics on measurement results across the entire recording can be viewed in the Dashboard page; see *Dashboard* (page 168).

*To clear recorded data:*

1. Toggle the **Data Source** to **Replay**.
2. Press the **Clear Replay** button.

### Downloading, Exporting, and Uploading Recorded Data

Recorded data can be downloaded or exported to the client computer, or uploaded to the Gocator. Export is often used for processing the recorded data using third-party tools. Exported data can be either range data in CSV format or intensity data in BMP format. Recorded data is downloaded in a binary format, which is used to back up the data for reviewing in the future.

 Recorded data is not saved or loaded along with other files when you use the Save or Load commands in the Gocator's toolbar

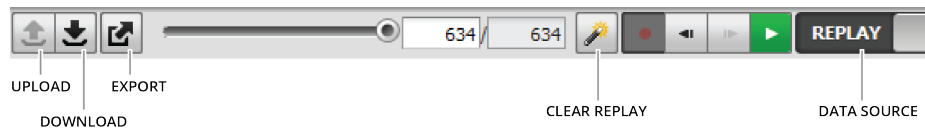

*To download recorded data:*

1. Toggle the **Data Source** to **Replay**.
2. Press the **Download** button.
3. Select the directory and file name to download to the client computer. Press **OK**.

*To upload recorded data:*

1. Toggle the **Data Source** to **Live**.
2. Press the **Upload** button.
3. Select the directory and the file name to upload from the client computer. Press **OK**.

Recorded data can be exported using the CSV format.

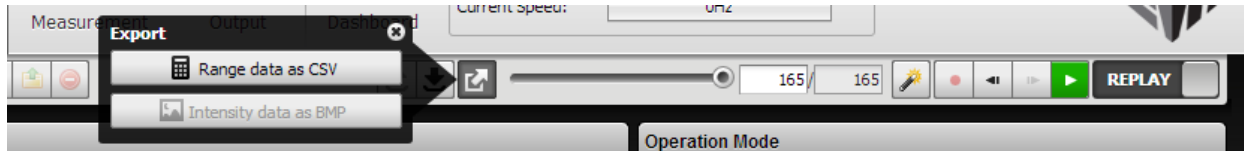

To export recorded data to CSV:

1. Toggle the **Data Source** to *Replay*.
2. Press the **Export** button.  
Select **Export Ranges as CSV**. In Profile and Raw mode, all data in the record buffer is exported. In Part mode, only data in the current replay location is exported. Use the *Step* button to move to a different replay location; see *Recording, Playback, and Measurement Simulation* (page 50).
3. Select the directory and file name to export to the client computer. Press **OK**.
4. Optionally, convert exported data to another format using the *CSV Converter Tool* (page 318).

Recorded intensity data can also be exported to a bitmap (.BMP format). **Acquire Intensity** must have been checked in the **Operation Mode** panel while data was being recorded.



To export recorded intensity data to BMP:

1. Toggle the **Data Source** to **Replay**.
2. Press the Export To BMP button.  
Select **Export Intensity as BMP**. Only the intensity data in the current replay location is exported. Use the **Step** button to move to a different replay location.
3. Select the directory and file name to store on the client computer. Press **OK**.

## Metrics Panel

The Metrics panel displays two important performance statistics in real-time: CPU load and current frame rate (speed).

The **CPU Load** bar in the **Metrics** panel (at the top of the interface) displays how much of the CPU is being utilized. A warning symbol will appear if the sensor drops profiles because CPU is over utilized.

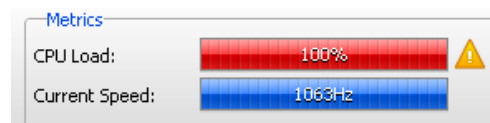

The Speed bar displays the frame rate of the sensor. A warning symbol will appear if triggers (external input or encoder) are dropped because the external rate exceeds the maximum frame rate.

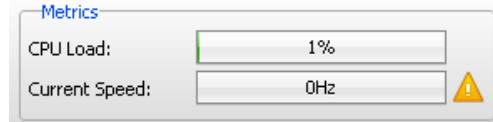

Click on a warning symbol to reveal notifications that display more detailed information.

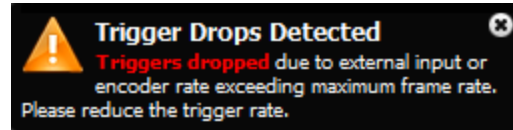

## Data Viewer

The data viewer is displayed in both the **Setup** and the **Measurement** pages, but displays different information depending on which page is active.

When the **Setup** page is active, the data viewer displays sensor data and can be used to adjust regions of interest. Depending on the selected operation mode (page 64), the data viewer can display video images or whole part views. For details, see *Data Viewer* (page 86).

When the **Measurement** page is active, the data viewer displays sensor data onto which representations of measurement tools and their measurements are superimposed. For details, see *Data Viewer* (page 97).

# Connection and Maintenance

The following sections describe how to set up the sensor connections and networking, and how to perform maintenance tasks.

## Connection Page Overview

Gocator's security, file management, and maintenance tasks are performed on the **Connection** page.

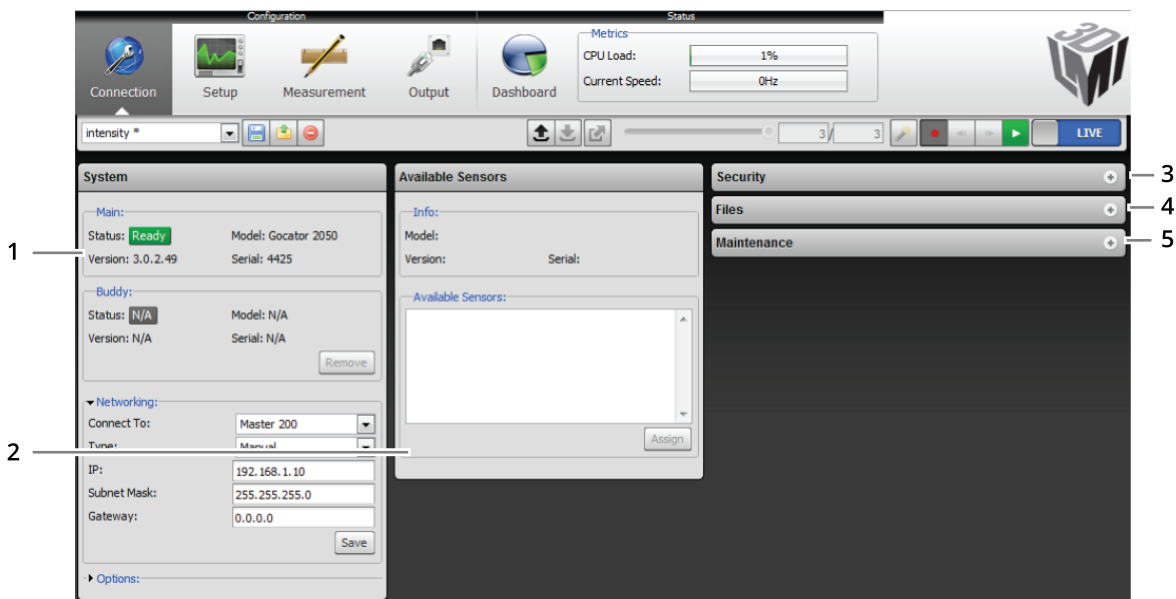

Element	Description
1 System panel	Use the <b>System</b> panel to configure sensor network and boot-up settings. See <i>System Panel</i> (below).
2 Available Sensors panel	Use the <b>Available Sensors</b> panel to assign or unassign Buddy sensors. See <i>Available Sensors</i> (page 56).
3 Security panel	Use the <b>Security</b> panel to change passwords. See <i>Security Panel</i> (page 57).
4 Files panel	Use the <b>Files</b> panel to manage files stored on the Main sensor. See <i>Files Panel</i> (page 58).
5 Maintenance panel	Use the <b>Maintenance</b> panel to upgrade firmware, create/restore backups, or reset sensors. See <i>Maintenance Panel</i> (page 58).

## System Panel

The following sections describe the **System** panel.

### Network Settings

The network settings must be configured to match the network to which the Gocator sensors are connected.

To configure the network settings:

1. Navigate to the **System** panel.  
Click the arrow next to **Networking** to expand the panel.
2. Specify the **Connect To** setting.  
The **Connect To** setting specifies whether the sensor system is standalone or connected to a Master.
3. Specify the Type, IP, Subnet Mask, and Gateway settings.  
The Gocator sensor can be configured to use DHCP or assigned a static IP address.
4. Click **Save**.  
When you click the *Save* button, you will be prompted to confirm your selection.
5. Reset or power-cycle the sensor.  
After changing network settings, the sensor must be reset or power-cycled before the change will take effect.  
The **Reset Sensor** button in the Maintenance panel (page 58) can be used to perform a software reset.

## Sensor Autostart

With the Autostart setting enabled, laser profiling and measurement functions will begin automatically when the sensor is powered on. This setting is necessary when the sensor will be used without a computer connected.

To enable/disable Autostart:

1. Check/Uncheck the **Autostart** option box.
2. Save your configuration.

## Overheat Temperature Protection

Sensors equipped with a 3B-N laser by default will turn off the laser if the temperature exceeds the safe operating range. You can override the setting by disabling the overheat protection.



Disabling the setting is not recommended. Disabling the overheat protection feature could lead to premature laser failure if the sensor operates outside the specified temperature range.

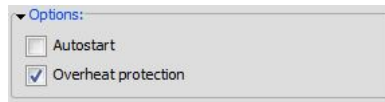

To enable/disable overheat temperature protection:

1. Check/uncheck the **Overheat Protection** option box.
2. Save configuration.

## Available Sensors

The following section describes the **Available Sensors** panel.

### Buddy Assignment

In a dual-sensor system, the *Main* sensor assumes control of the *Buddy* sensor after the Buddy sensor is assigned to the Main sensor. Configuration for both sensors can be performed through the Main sensor's interface.



Main and Buddy sensors must be assigned unique IP addresses before they can be used on the same network. Before proceeding, connect the Main and Buddy sensors one at a time (to avoid an address conflict) and use the steps outline in Running a Dual-Sensor System (page 30) to assign each sensor a unique address.

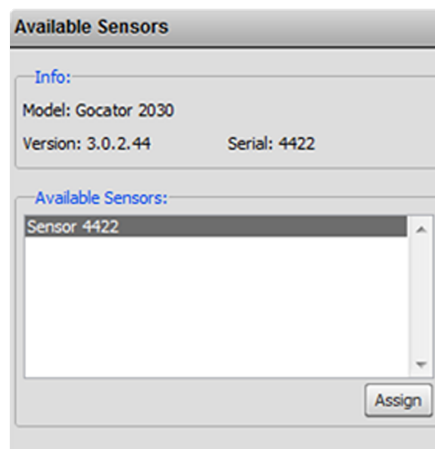

To assign a Buddy sensor:

1. Navigate to the **Available Sensors** panel.
2. Select a Buddy sensor.  
The firmware on Main and Buddy sensors must be the same for Buddy assignment to be successful. If the firmware is different, connect the Main and Buddy sensor one at a time.
3. Click **Assign**.  
The Buddy sensor will be assigned to the Main sensor and its status will be updated in the **System** panel.

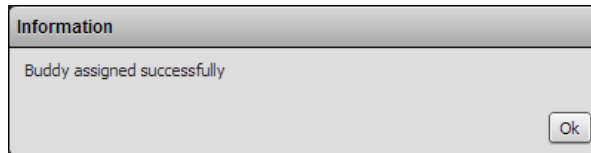

## Security Panel

Gocator sensors can be secured with passwords to prevent unauthorized access. Each sensor has two accounts: Administrator and Technician.



### Gocator Account Types

Account	Description
Administrator	The Administrator account has privileges to view and edit all settings, and to perform setup procedures such as sensor calibration.
Technician	The Technician account has privileges to view the Dashboard Page and to Start or Stop the sensor.

The Administrator and Technician accounts can be assigned unique passwords. By default, passwords are blank (empty).

#### To set or change the password for the Administrator account:

1. Navigate to the **Security** panel.  
Click the arrow next to **Administrator** to expand the panel.
2. Enter the new Administrator account password and password confirmation.
3. Click **Save**.  
The new password will be required the next time that an administrator logs in to the sensor.

#### To set or change the password for the Technician account:

1. Navigate to the **Security** panel.  
Click the arrow next to **Technician** to expand the panel.
2. Enter the new Technician account password and password confirmation.
3. Click **Save**.  
The new password will be required the next time that a technician logs in to the sensor.

If the administrator or technician password is misplaced, the sensor can be recovered using a special software tool. See *Sensor Recovery Tool* (page 311) for more information.

## Files Panel

The **Files** panel can be used to manage configuration, calibration, and template files.

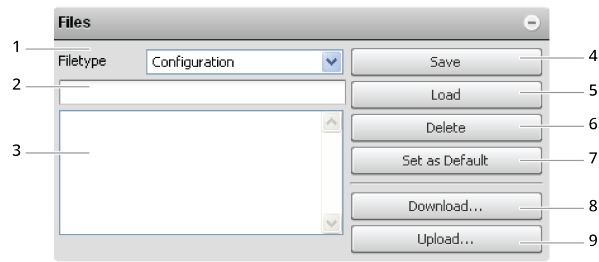

Element	Description
1 File Type	Specifies the type of files to manage (configuration, profile template, or transformation).
2 File Name Field	Used to provide a file name when saving files.
3 File List	Displays the files that are currently saved in the sensor's flash storage.
4 Save Button	Saves currently loaded data to file using the name in the <b>File Name</b> field.
5 Load Button	Loads the file that is selected in the file list.
6 Delete Button	Deletes the file that is selected in the file list.
7 Set as Default Button	Sets the selected file as the default to be loaded at boot time.
8 Download Button	Downloads the selected file to the client computer.
9 Upload Button	Uploads a file from the client computer.

The following types of files can be saved and loaded:

### File Types

File Type	Description
Configuration	Contains the settings specified in the <b>Setup</b> , <b>Measurement</b> , and <b>Output</b> pages.
Transformation	Contains settings resulting from calibration.
Profile Template	Contains profile template data used for profile fixturing.

*To manage a configuration, calibration, or template file:*

1. Navigate to the **Files** panel.
2. Select the file type.
3. Select the file in the **File** list.  
To save the live configuration, calibration, or template to a file, type in a new file name or select a file to replace with.
4. Select the action.

## Maintenance Panel

The following sections describe the **Maintenance** panel.

## Sensor Backups and Factory Reset

The **Maintenance** panel can be used to create sensor backups, restore from a backup, or restore to factory defaults.

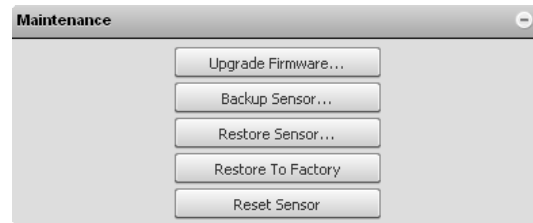

Backup files contain all of the information stored on a sensor, including configuration, calibration, and template.



An Administrator should create a backup file in the unlikely event that a sensor fails and a replacement sensor is needed. If this happens, the new sensor can be restored with the backup file.

*To create a backup:*

1. Navigate to the **Maintenance** panel.
2. Click the **Backup Sensor...** button.
3. When you are prompted, specify a location for the backup.  
The backup is saved to the specified location on the client computer. Backups are saved as a single archive that contains all of the files from the sensor.

*To restore from a backup:*

1. Navigate to the **Maintenance** panel.
2. Click the **Restore Sensor...** button.
3. When you are prompted, select a backup file to restore.  
The backup file is uploaded and then used to restore the sensor. Any files that were on the sensor before the restore operation will be lost.

*To restore a sensor to its factory default settings:*

1. Navigate to the **Maintenance** panel.
2. Consider making a backup.  
Before proceeding, you should perform a backup. Restoring factory defaults cannot be undone.
3. Click the **Restore to Factory** button.
4. Reset the sensor.  
After restoring factory defaults, you must reset the sensor before the changes will take effect. Use the **Reset Sensor** button or cycle the power to reset the sensor.

## Firmware Upgrade

LMI recommends routinely updating firmware to ensure that Gocator sensors always have the latest features and fixes.



In order for the Main and Buddy sensors to work together, they must be use the same firmware version. This can be achieved by upgrading through the Main sensor or by upgrading each sensor individually.

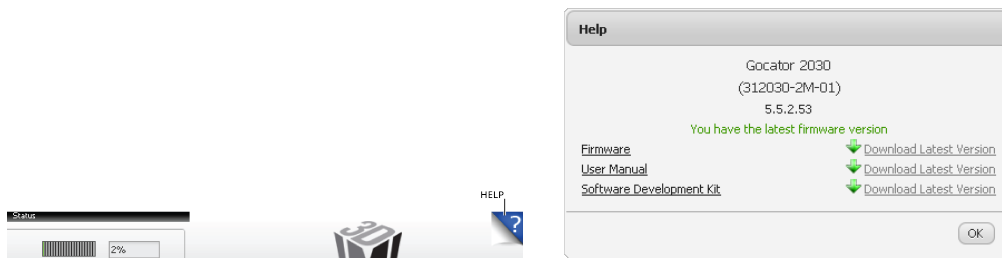

*To download the latest firmware:*

1. Click on the **Help** link.  
Make sure that the client computer is connected to the Internet.
2. Determine if an update is required.  
The **Help** panel will check LMI's website to check if the sensor's firmware is up to date.
3. Download the latest firmware.  
If sensor firmware is not up to date, click the **Firmware** link to visit LMI's website, and then download the latest firmware.

If the client computer is not connected to the Internet, firmware can be downloaded and transferred to the client computer by using another computer to download the firmware from LMI's website:  
<http://www.lmi3d.com/support/downloads>.

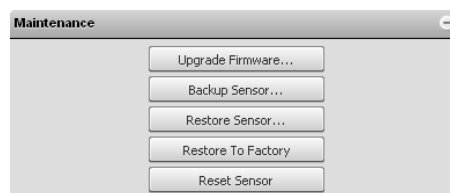

*To upgrade the firmware:*

1. Navigate to the **Maintenance** panel.
2. Click the **Update Firmware** button.
3. Provide the location of the firmware file in the **File** dialog.
4. Wait for the upgrade to complete.  
After the firmware upgrade is complete, the sensor will self-reset. If a buddy has been assigned, it will be upgraded and reset automatically.

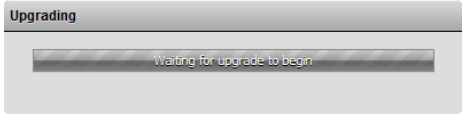

# Setup and Calibration

The following sections describe the steps to configure Gocator sensors for laser profiling using the **Setup** page. Setup and calibration steps should be performed before programming measurements or outputs.

 Calibration in the user interface and in this manual refers to aligning a sensor to system coordinates.

## Setup Page Overview

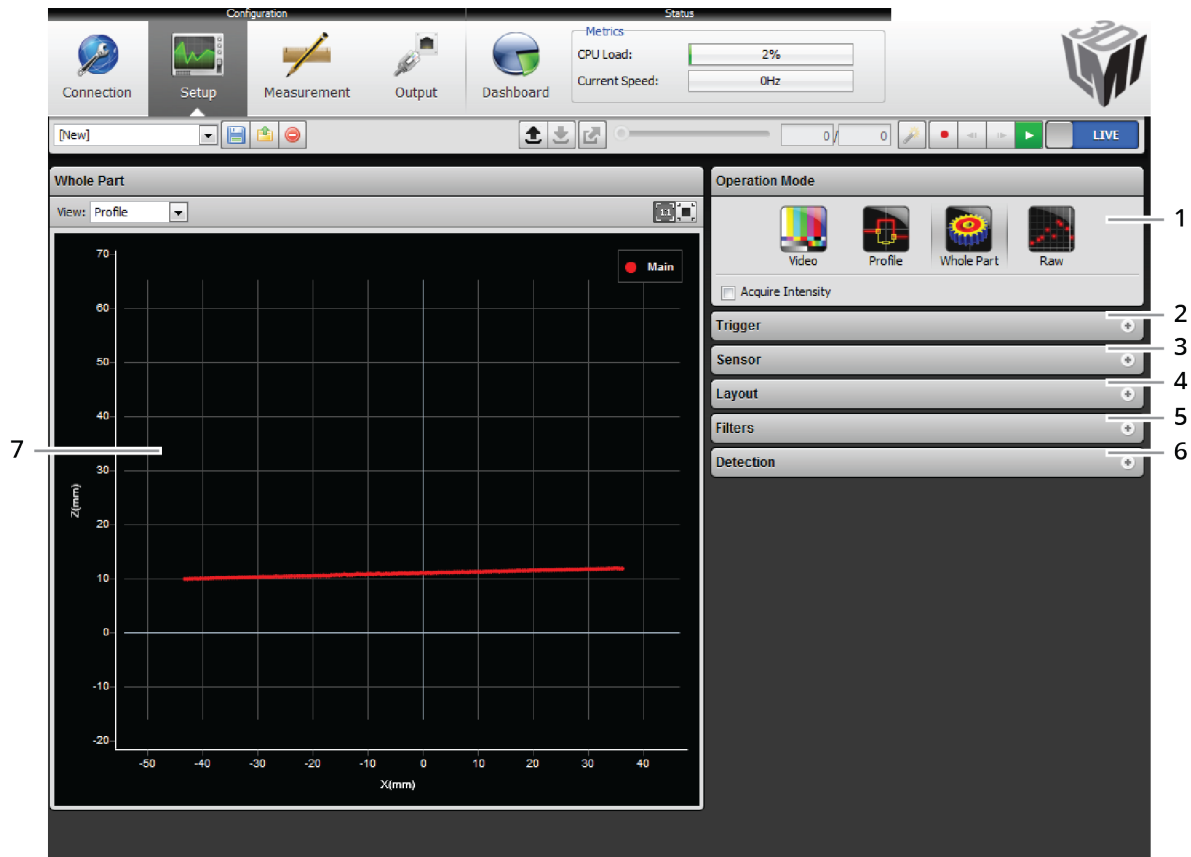

Element	Description
1 Operation Mode panel	Use the <b>Operation Mode</b> panel to set the current operation mode (Video, Profile, Part, or Raw) and other options. See <i>Operation Mode Panel</i> (page 64).
2 Trigger panel	Use the <b>Trigger</b> panel to specify the trigger source and trigger-related settings. See <i>Trigger Panel</i> (page 64).
3 Sensor panel	Use the <b>Sensor</b> panel to specify settings for an individual sensor, such as active area or exposure. See <i>Sensor Panel</i> (page 69).
4 Layout panel	Use the <b>Layout</b> panel to configure a dual-sensor (Main/Buddy) system and to perform alignment or travel calibration. See <i>Layout Panel</i> (page 77).
5 Filters panel	Use the <b>Filters</b> panel to specify settings for post-processing of the profiles. See <i>Filters Panel</i> (page 82).

Element	Description
6 Detection panel	Use the <b>Detection</b> panel to set the part detection logic for sorting profiles into discrete objects. See <i>Detection Panel</i> (page 85).
7 Data Viewer	Use the data viewer to display sensor data and adjust regions of interest. Depending on the current operation mode, the data viewer can display video images , profile plots, or part views . See <i>Data Viewer</i> (page 86).

The following table provides quick references for specific goals that you can achieve from the panels in the **Setup** page.

Goal	Reference
1 Select a trigger source that is appropriate for the application.	Trigger Panel (next page)
2 Ensure that camera exposure is appropriate for laser profiling .	Exposure (page 71)
3 Find the right balance between profile quality, speed, and CPU utilization.	Active Area (page 69) Exposure (page 71) Gocator Device Files (page 171)
4 Specify mounting orientations for dual-sensor systems.	Dual-Sensor System Layout (page 77)
5 Calibrate the system so that laser profile data can be aligned to a common reference and values can be correctly scaled in the axis of motion.	Alignment Calibration (page 80) Travel Calibration (page 279)
6 Specify smoothing, gap-filling, and resampling parameters to remove effects of occlusions.	Filters Panel (page 82)
7 Set up the part detection logic to sort profiles into discrete objects.	Detection

Goal	Reference
	Panel (page 85)

## Operation Mode Panel

The Gocator web interface supports four operation modes: Video, Profile, Raw, and Whole Part. The operation mode can be selected in the **Operation Mode** panel.

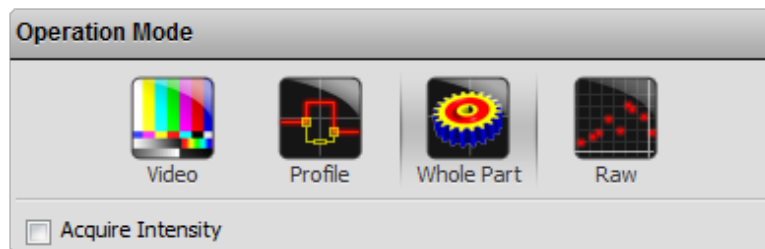

Mode and Option	Description
Video	Outputs video images from the Gocator. This mode is useful for configuring exposure time and troubleshooting stray light or ambient light problems.
Profile	Outputs profiles and performs profile measurements. Video images are processed internally to produce laser profiles and cross-sectional measurements.
Whole Part	Outputs 3D point clouds and performs part measurements. Laser profiles are sorted into discrete parts. The parts are then processed internally to produce measurements. "Whole Part" is often referred to as "Part" in the Gocator web interface and in this document.
Raw	Outputs profiles. In Raw Mode, video images are processed internally by the sensor to produce laser profiles. Use this mode to extract unprocessed ranges from the Gocator at the highest possible rate. Post-profiling processing and measurements are disabled.
Acquire Intensity	When this option is enabled, an intensity value will be produced for each laser profile point.

## Trigger Panel

A trigger is an event that causes a sensor to take a single picture. When a trigger is processed, the laser is strobed and the camera exposes to produce an image. The resulting image is processed inside the sensor to yield a profile (range/distance information), which can then be used for measurement.

The laser and camera inside a sensor can be triggered by one of the following sources:

Trigger Source	Description
Time	Sensors have an internal clock that can be used to generate fixed-frequency triggers. The external input can be used to enable or disable the time triggers.
Encoder	An encoder can be connected to provide triggers in response to motion. Three encoder triggering behaviors are supported: <ol style="list-style-type: none"> <li>1. Track Backward</li> </ol>

---

**Trigger Source****Description**

A scan is triggered when the target object moves forward. If the target object moves backward, it must move forward by at least the distance that the target travelled backward (this distance backward is "tracked"), plus one encoder spacing, to trigger the next scan.

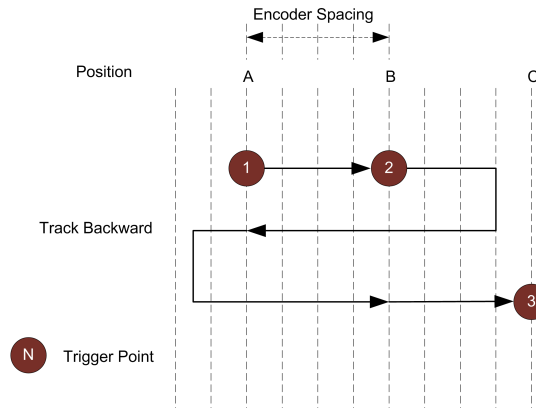
**2. Ignore Backward**

A scan is triggered only when the target object moves forward. If the target object moves backward, it must move forward by at least the distance of one encoder spacing to trigger the next scan.

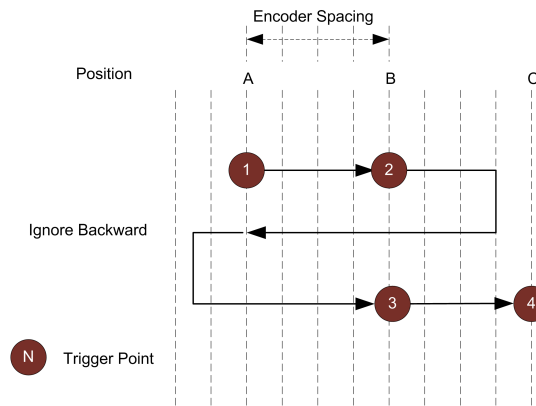
**3. Bi-directional**

A scan is triggered when the target object moves forward or backward.

---

Trigger Source	Description
----------------	-------------

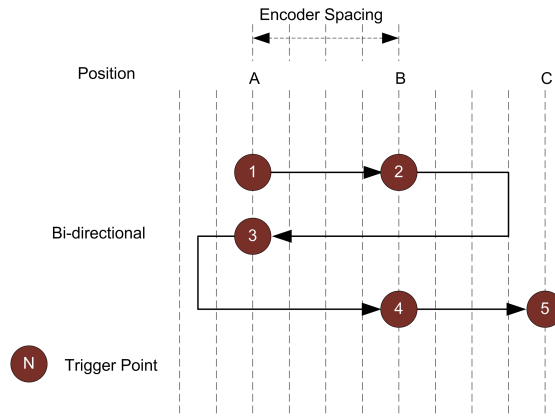

When triggers are received at a frequency higher than the maximum frame rate, some triggers may not be accepted. The **Trigger Drops Indicator** in the **Dashboard** page can be used to check for this condition.

The external input can be used to enable or disable the encoder triggers.

See *Encoder Input* on pages 353 and 360 for more information on connecting the encoder to Gocator sensors.

External Input	A digital input can provide triggers in response to external events (e.g., photocell). When triggers are received at a frequency higher than the maximum frame rate, some triggers may not be accepted. The <i>Trigger Drops Indicator</i> in the <i>Dashboard</i> can be used to check for this condition. See <i>Digital Inputs</i> on pages 352 and 359 for more information on connecting external input to Gocator sensors.
----------------	----------------------------------------------------------------------------------------------------------------------------------------------------------------------------------------------------------------------------------------------------------------------------------------------------------------------------------------------------------------------------------------------------------------------------------------

Software	A network command can be used to send a software trigger. See <i>Protocols</i> (page 253) for more information.
----------	-----------------------------------------------------------------------------------------------------------------

For examples of typical real-world scenarios, see below. For information on the settings used with each trigger source, see next page

## Trigger Examples

### Example: Encoder + Conveyor

Encoder triggering is used to perform profile measurements at a uniform spacing. The speed of the conveyor can vary while the object is being measured; an encoder ensures that the measurement spacing is consistent, independent of conveyor speed.

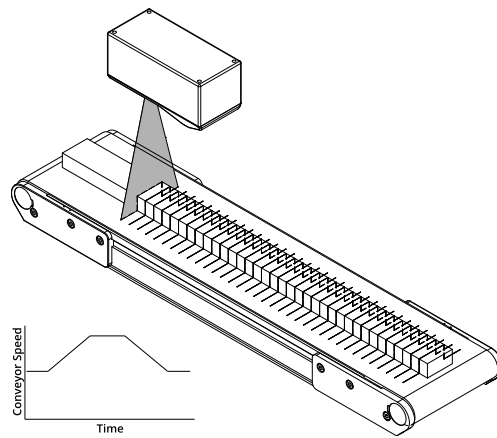

### Example: Time + Conveyor

Time triggering can be used instead of encoder triggering to perform profile measurements at a fixed frequency.

Measurement spacing will be non-uniform if the speed of the conveyor varies while the object is being measured.

It is strongly recommended to use an encoder with transport-based systems due to the difficulty in maintaining constant transport velocity.

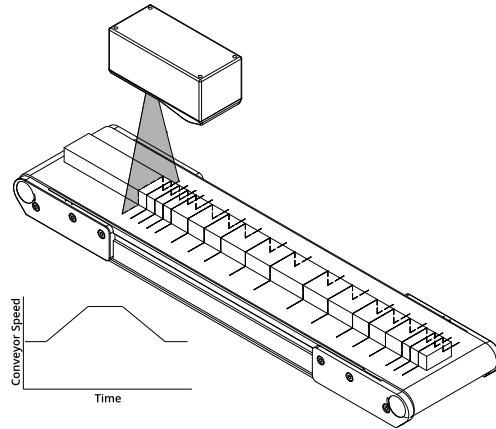

### Example: External Input + Conveyor

External Input triggering can be used to produce a snapshot for profile measurement. For example, a photocell can be connected as an External Input to generate a trigger pulse when a target object has moved into position. An External Input can also be used to gate the trigger signals when Time or Encoder triggering is used. For example, a photocell could generate a series of trigger pulses as long as there is a target in position.

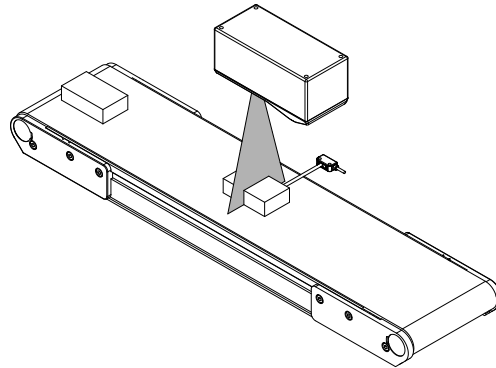

### Example: Software Trigger + Robot Arm

Software triggering can be used to produce a snapshot for profile measurement. A software trigger can be used in systems that use external software to control the activities of system components.

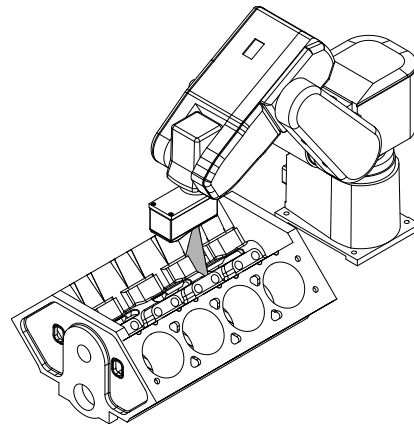

## Trigger Settings

The trigger source is selected using the **Trigger** panel in the **Setup** page.

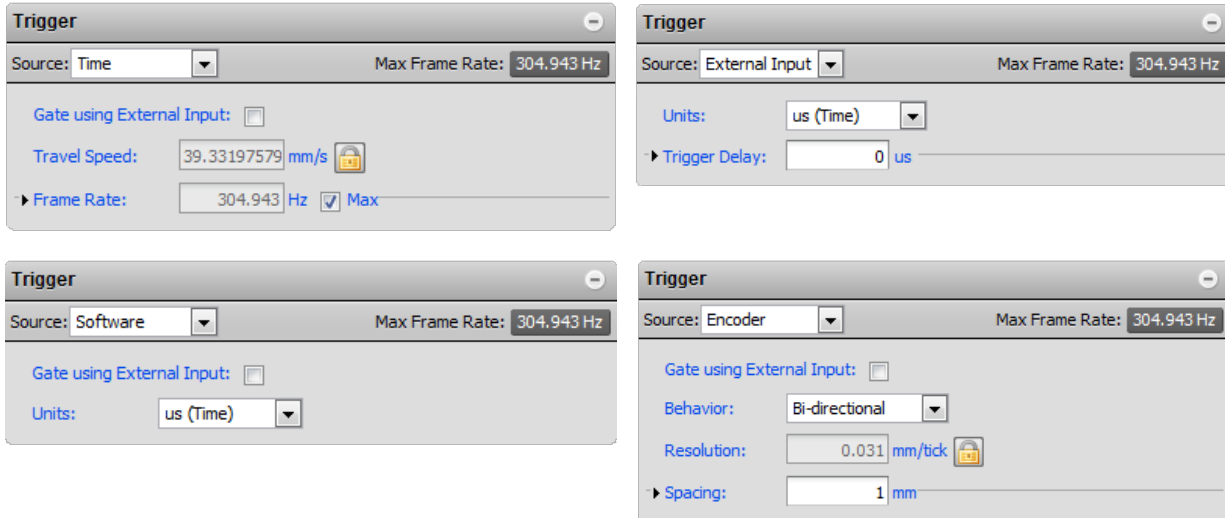

After specifying a trigger source, the **Trigger** panel will show the parameters that can be configured.

Parameter	Trigger Source	Description
Trigger	All	Selects the trigger source (Time, Encoder, External Input, or Software).
Max Frame Rate	All	Reports the maximum frame rate, which is a function of the current Active Area, Exposure, and Resolution settings.
Frame Rate	Time	The Frame Rate setting can be used to control the frame rate. Select the Max check box to lock to the maximum frame rate. Fractional values are supported. For example, 0.1 can be entered to run at 1 frame every 10 seconds.
Gate using External Input	Time, Encoder	External input can be used to enable or disable profiling in a sensor. When this option is enabled, the sensor will respond to time or encoder triggers only when the external input is asserted. See <i>Digital Inputs</i> on pages 352 and 359 for more information on connecting external input to Gocator sensors.
Travel Speed	Time	Travel Speed provides proper scaling in the Y axis (axis of motion). Travel Speed can be calculated automatically by performing Travel Calibration or set manually after clicking on the unlock button.
Encoder Behavior	Encoder	Encoder Behavior setting is used to specify how the Gocator sensor is triggered when the target moves.
Encoder Resolution	Encoder	Encoder Resolution (millimeters per tick) provides proper scaling in the Y axis (axis of motion). The encoder resolution can be calculated automatically by performing Travel Calibration or set manually after clicking on the unlock button.
Spacing	Encoder	Encoder Spacing setting is used to specify the distance between triggers (mm). Internally the Gocator sensor rounds the spacing to a multiple of the encoder resolution.
Units	External Input, Software	Units specifies whether the trigger delay, output delay and output scheduled command operates in the time or the encoder domain. The unit is implicitly set to microseconds with Time trigger source, and millimeters with Encoder trigger

Parameter	Trigger Source	Description
		source.
Trigger Delay	External Input	Trigger delay can be used to control the amount of time or the distance the sensor waits before producing a frame after the external input is activated. This is used to compensate for the positional difference between the source of the external input trigger (e.g., photocells) and the sensor. Trigger delay is only supported in single exposure mode; for details, see <i>Exposure</i> (page 71).

## Sensor Panel

The following sections describe the **Sensor** panel.

### Active Area

Active area refers to the region within the sensor's maximum field of view that is used for laser profiling.

By default, the active area covers the sensor's entire field of view. By reducing the active area, the sensor can operate at higher speeds.

Active area is specified in sensor coordinates, rather than in system coordinates. As a result, if the sensor is already alignment calibrated, press the **Acquire** button to display uncalibrated data before configuring the active area. See *Coordinate Systems* (page 44) for more information on sensor and system coordinates.

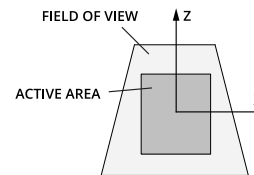
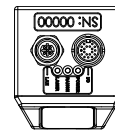

**Sensor**

▼ **Active Area:**

Select    Reset    Acquire

	Values	Min/Max
X Field of View:	<input type="text" value="100"/> mm	0.000 / 100.000
Y Field of View:	<input type="text" value="170"/> mm	0.000 / 170.000
Measurement Range:	<input type="text" value="100"/> mm	0.000 / 100.000
X-Start:	<input type="text" value="-50"/> mm	-50.000 / -50.000
Y-Start:	<input type="text" value="-85"/> mm	-85.000 / -85.000
Z-Start:	<input type="text" value="-50"/> mm	-50.000 / -50.000

▶ Exposure: \_\_\_\_\_

▶ Resolution: \_\_\_\_\_

▶ Transformations:

To set the active area:

1. Navigate to the **Sensor** panel.  
Active area is specified separately for each sensor. Click the arrow next to **Active Area** to expand the panel.
2. Click the **Select** button.
3. Define the active area.  
Enter the active area in the edit box or adjust it graphically in the data viewer.
4. Click the **Acquire** button to see a scan while setting up the active area.
5. Click the **Save** button.



Laser profiling devices are usually more accurate at the near end of their measurement range. If your application requires a measurement range that is small compared to the maximum measurement range of the sensor, mount the sensor so that the active area can be defined at the near end of the measurement range.

## Tracking Window

The Gocator can track a relatively flat object in real-time to achieve very high scan rates. This feature tracks the object height using a small window that moves dynamically to cover a larger measurement range. You can balance the gain in speed and the tracking ability by configuring the size of the tracking area. This feature is typically used in road or web scanning applications where the target is a continuous flat surface.

A laser line remains tracked as long as the percentage of detected laser points exceeds the user-defined search threshold. When the sensor loses track of the laser line, the sensor will search for the laser line using the full active area.

Tracking window is only supported on the Gocator 2300 series.

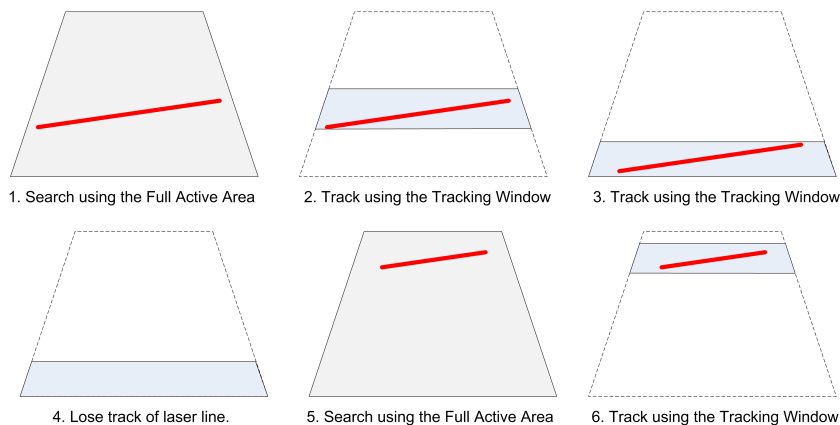

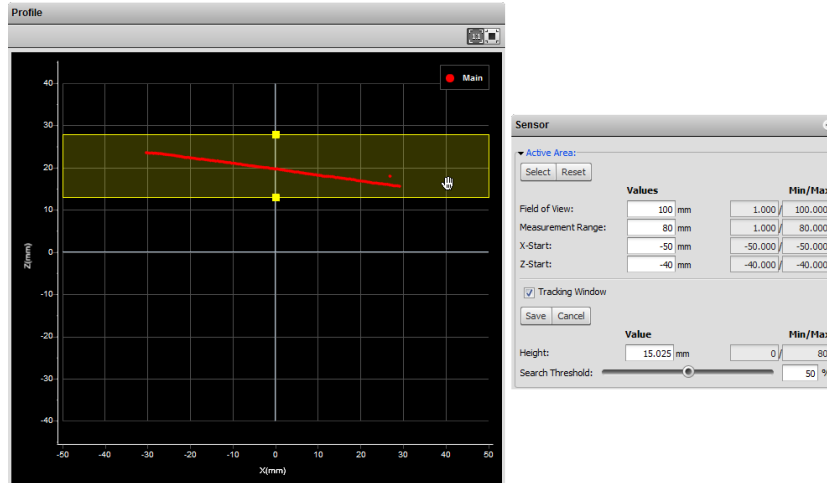

To enable the tracking window:

1. Check the **Tracking Window** box.  
Checking the **Tracking Window** box expands the panel and shows the settings for the window used to track the object height.
2. Resize the tracking window shown in the data viewer.  
Only the height of the window is required. You can move the position of the tracking window to cover a live profile to help adjust the window height.
3. Edit the **Search Threshold** setting.  
The search threshold defines the minimum percentage of the points detected across the profile for the laser to be considered tracked. If tracking is lost, the sensor will search for the laser using the full active area.

The sensor adjusts the position of the tracking window so that the area is centered around the average height of the entire visible laser profile. You should adjust the lighting and the active area to remove all background objects, such as the conveyor belt surface, ambient lights, etc.

## Exposure

Exposure determines the duration of camera and laser on-time. Longer exposures can be helpful to detect laser signals on dark or distant surfaces, but increasing exposure time decreases the maximum speed. Different target surfaces may require different exposures for optimal results. Gocator sensors provide three exposure modes for the flexibility needed to scan different types of target surfaces.

Exposure Mode	Description
Single	Uses a single exposure for all objects. Used when the surface is uniform and is the same for all targets.
Dynamic	Automatically adjusts the exposure after each frame. Used when the target surface varies between scans.
Multiple	Uses multiple exposures to create a single profile. Used when the target surface has a varying reflectance within a single profile (e.g., white and black).

Video mode lets you see how the laser line appears on the camera and identify any stray light or ambient light problems. When exposure is tuned correctly, the laser should be clearly visible along the entire length of the viewer. If it is too dim, increase the exposure value; if it is too bright decrease exposure value.



*Under exposure  
Laser line is not detected.  
Increase the exposure value.*

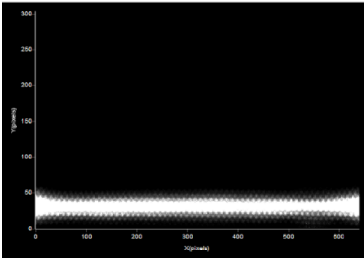

*Over exposure  
Laser line is too bright .  
Increase the exposure value.*

 In a dual-sensor system, the Main and the Buddy sensor must use the same exposure mode or the system will fail to start.

When the Gocator is in Multiple exposure mode, select which exposure to view using the drop-down box next to "View" in the data viewer. This drop-down is only visible in Video operation mode when the Multiple option is selected in the Exposure section in the Sensor panel.

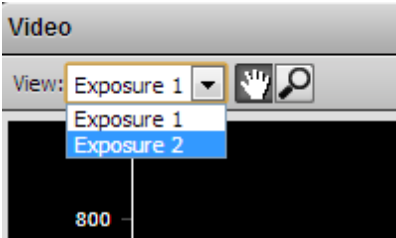

### Single Exposure

The sensor uses a fixed exposure in every scan. Single exposure is used when the target surface is uniform and is the same for all parts.

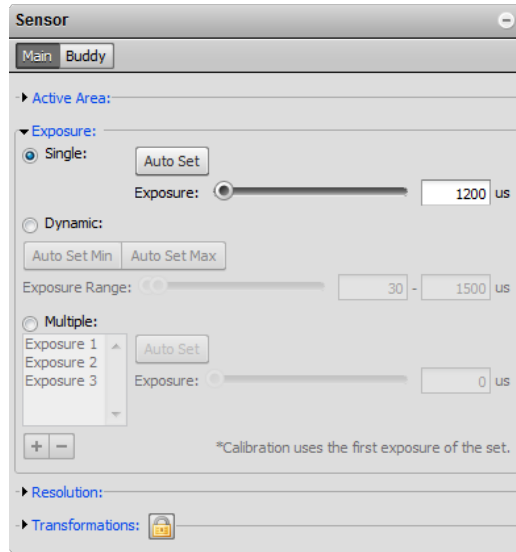

To enable single exposure:

1. Place a representative target in view of the sensor.  
The target surface should be similar to the material that will normally be measured.
2. Select **Profile, Part, or Raw** mode.
3. Navigate to the **Sensor** panel.  
Click the arrow next to **Exposure** to expand the panel. Click the **Main** or **Buddy** sensor button to select the sensor.
4. Select **Single**.
5. Edit the **Exposure** setting.  
You can automatically tune the exposure by pressing the **Auto Set** button, which causes the sensor to turn on and tune the exposure time.
6. Run the sensor and check that laser profiling is satisfactory.  
If not satisfactory, adjust the exposure values manually. Switch to **Video** mode to use video to help tune the exposure; see *Exposure* (page 71) for details.

## Dynamic Exposure

The sensor automatically uses past profile information to adjust the exposure to yield the best profile. This is used when the target surface changes from scan to scan.

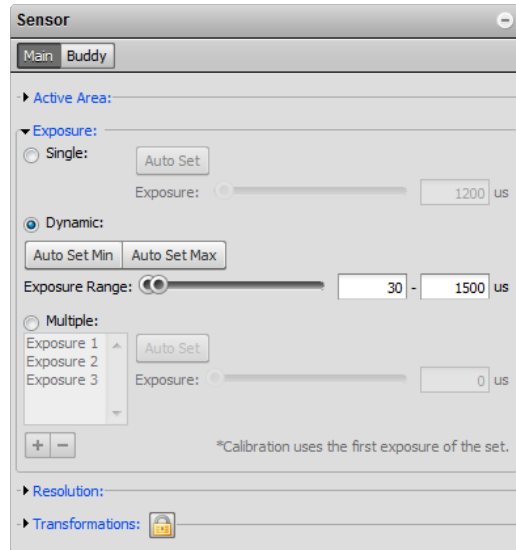

To enable dynamic exposure:

1. Select *Profile, Part, or Raw* mode.
2. Navigate to the **Sensor** panel.  
Click the arrow next to **Exposure** to expand the panel. Click the **Main** or **Buddy** sensor button to select the sensor.
3. Select **Dynamic**.
4. Set the minimum and maximum exposure.  
The auto-set function can be used to automatically set the exposure. First, place the brightest target in the field of view and press the **Auto Set Min** button to set the minimum exposure. Then, place the darkest target in the field of view and press the **Auto Set Max** button to set the maximum exposure.
5. Run the sensor and check that laser profiling is satisfactory.  
If not satisfactory, adjust the exposure values manually. Switch to **Video** mode to use video to help tune the exposure; see *Exposure* (page 71) for details.

## Multiple Exposures

The sensor combines data from multiple exposures to create a single laser profile. Multiple exposures can be used to increase the ability to detect light and dark materials that are in the field of view simultaneously.

Up to five exposures can be defined with each set to a different exposure level. For each exposure, the sensor will perform a complete scan at the current frame rate making the effective frame rate slower. For example, if two exposures are selected, then the speed will be half of the single exposure frame rate. The sensor will perform a complete multi-exposure scan for each external input or encoder trigger.

The resulting profile is a composite created by combing data collected with different exposures. The sensor will choose profile data that is available from the lowest-numbered exposure step. It is recommended to use a larger exposure for higher-numbered steps.

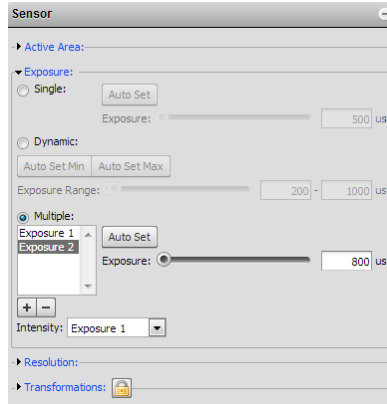

 You must make sure that the exposure steps set for composite exposure are the same between the Main and Buddy sensors in dual-sensor mode

*To enable multiple exposures:*

1. Select Profile, Part, or Raw mode.
2. Navigate to the **Sensor** panel.  
Click the arrow next to **Exposure** to expand the panel. Click the **Main** or **Buddy** sensor button to select the sensor.
3. Select **Multiple**.
4. Press the + button to add an exposure step.  
Up to a maximum of five exposure settings can be added.
5. Set the exposure level to make the Gocator's camera less or more sensitive, as required.  
If **Acquire Intensity** is enabled, select the exposure step that is used to capture the intensity output.
6. Run the sensor and check that laser profiling is satisfactory.  
If not satisfactory, adjust the exposure values manually. Switch to **Video** mode to use video to help tune the exposure; see *Exposure* (page 71) for details.

## Resolutions

Resolutions can be set independently for the X axis and Z axis. Reducing the resolution increases speed or reduces CPU usage while maintaining the sensor's field of view.

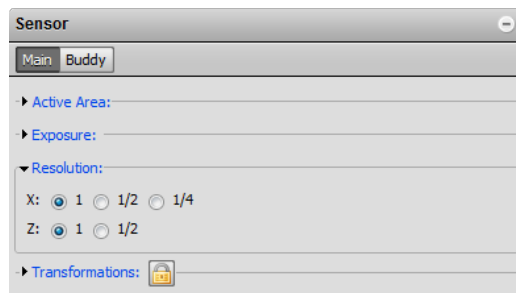

## X Resolution

The **X Resolution** setting can be used to decrease the profile's X resolution to decrease sensor CPU usage. The **X Resolution** setting works by reducing the number of image columns used for laser profiling.



The **CPU Load** bar at the top of the interface displays how much of the CPU is being used.

*To configure X resolution:*

1. Navigate to the **Sensor** panel.  
Click the arrow next to **Resolution** to expand the panel. Click the **Main** or **Buddy** button to select the sensor. X resolution is specified separately for each sensor.
2. Select a resolution value.  
X resolution values are expressed as fractions. For example, a resolution value of 1/2 indicates that every second camera column will be used for laser profiling.
3. Check that laser profiling is satisfactory.  
After adjusting the resolution, confirm that laser profiling is satisfactory.

## Z Resolution

The **Z Resolution** setting can be used to decrease the profile's Z resolution to increase speed. The **Z Resolution** setting works by reducing the number of image rows used for laser profiling.



On the Gocator 2000, decreasing the Z resolution will increase speed. On the Gocator 2300, both the X and the Z resolutions must be decreased to increase speed.

*To configure Z resolution:*

1. Navigate to the **Sensor** panel.  
Click the arrow next to **Resolution** to expand the panel. Click the **Main** or **Buddy** button to select the sensor. Z resolution is specified separately for each sensor.
2. Select a resolution value.  
Z resolution values are expressed as fractions. For example, a resolution value of 1/2 indicates that every second camera row will be used for laser profiling.
3. Check that laser profiling is satisfactory.  
Decreasing Z resolution can reduce laser profiling accuracy. After adjusting the resolution, confirm that laser profiling is satisfactory.

## Transformations

The transformation settings are used to control how profiles are converted from sensor coordinates to system coordinates.



The system coordinate transformation is normally set through the Gocator's automatic calibration procedure and are locked by default; see *Calibration* (page 78). However, if you need to manually adjust the transformation, the settings are available in this section.

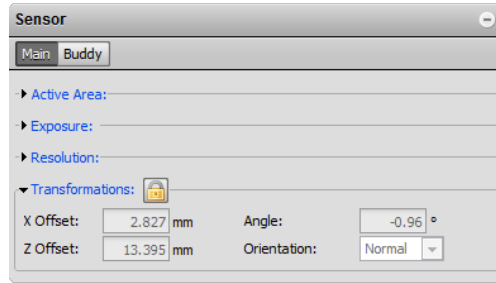

Element	Description
X Offset	Specifies the shift along the X axis. With Normal orientation, a positive value shifts the profiles to the right. With Reverse orientation, a positive value shifts the profile to the left.
Z Offset	Specifies the shift along the Z axis. A positive value shifts the profiles toward the sensor.
Angle	Specifies the tilt (rotation in the X-Z plane). A positive value rotates the profile counter-clockwise.
Orientation	Specifies the direction of the X axis. Setting to Reverse will flip the profile about the Z axis.

When applying the transformations, Angle is applied before the X and Z offsets.

To configure transformation settings:

1. Select **Profile, Part, or Raw** mode.
2. Navigate to the **Sensor** panel.  
Click the arrow next to **Transformation** to expand the panel. Click the **Main** or **Buddy** button to select the sensor. Transformations can be configured separately for each sensor.
3. Click the unlock button to make the fields editable.
4. Set the parameter values.
5. Check that the transformation settings are applied correctly after profiling is restarted.

## Layout Panel

The following sections describe the **Layout** panel.





### Dual-Sensor System Layout

Mounting orientations must be specified for a dual-sensor system. This information allows the Alignment or Travel Calibration procedures to determine the correct system-wide coordinates for laser profiling and measurements. See *Coordinate Systems* (page 44) for more information on sensor and system coordinates.

To specify the layout, navigate to the **Layout** panel on the **Setup** page:

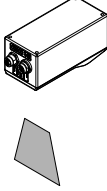

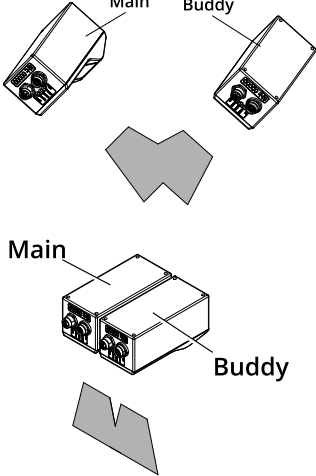
## Supported Orientations

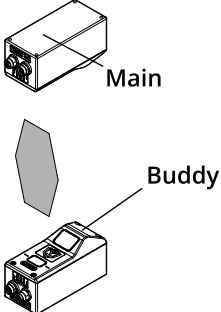
	Orientation	Example
	<p><b>None (Isolated)</b></p> <p>Each sensor operates as an isolated device. Measurements are reported in a separate coordinate system for each sensor.</p>	
	<p><b>Wide</b></p> <p>Sensors are mounted in Left (Main) and Right (Buddy) positions for a larger combined field of view. Sensors may be angled to avoid occlusions.</p>	
	<p><b>Opposite</b></p> <p>Sensors are mounted in Top (Main) and Bottom (Buddy) positions for a larger combined measurement range and the ability to perform Top/Bottom differential measurements.</p>	

## Overlap

If the Main and Buddy sensors are mounted such that the camera from one sensor can detect the laser from the other sensor, the **Overlap** option can be used to eliminate laser interference. This option creates a time offset for laser exposures and ensures that interfering lasers are not strobed at the same time. Use of the **Overlap** option may reduce the maximum frame rate.

## Reverse

In Wide orientation (see page 56 for information on orientations), the Buddy sensor can be mounted such that it is rotated 180 degrees around the Z axis to prevent occlusion along the Y axis. Enable the *Reverse* option when the buddy is mounted in this orientation.

## Calibration

Although Gocator sensors are pre-calibrated and ready to deliver profiles in engineering units (mm) out of the box, calibration procedures are required to compensate for sensor mounting inaccuracies, to align

multiple sensors into a common coordinate system, and to determine the resolution (with encoder) and speed of the transport system.

Gocator sensors support two types of calibration procedures: alignment calibration and travel calibration. Travel calibration performs essentially the same role as alignment calibration, but calibrates encoder resolution and Y axis offsets in addition to the corrections provided by alignment calibration.

Once calibration has been completed, the derived transformation values will be displayed under **Transformations** in the **Sensor** panel; see *Transformations* (page 76) for details.

## Calibration States

A Gocator can be in one of three calibration states: None, Manual, or Auto.

### Calibration State

State	Explanation
None	Sensor has no calibration. Profiles are reported in default sensor coordinates.
Manual	Transformations or encoder resolution have been manually edited.
Auto	Sensor is calibrated using either alignment or travel calibration.

An indicator on the **Calibration** panel will display CALIBRATED, MANUALLY CALIBRATED, or NOT CALIBRATED, depending on the Gocator's state.

## Transformation Sources

Gocator sensors support two types of transformation sources: **Global** or **Current Configuration**. The choice for the transformation source depends on how the sensor will be used.

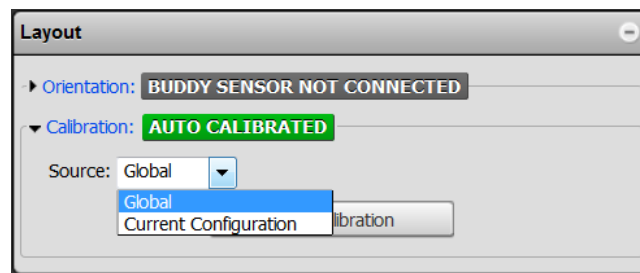

You can switch between transformation sources at any time.

Source	Description
Global transformation	<p>A single global transformation is applied to the profile that is acquired, regardless of what configuration is currently loaded on the sensor.</p> <p>The global transformation is saved on the sensor in a separate hidden file and is retained when the sensor is reset or powered off.</p> <p><b>Global</b> transformation is typically used when the sensor mounting is constant over time and between scans, e.g., when the sensor is mounted in a permanent position over a conveyor belt.</p>
Current Configuration	<p>The transformation is associated with a specific configuration.</p> <p>The transformation is saved with the same file name as the current configuration</p>

Source	Description
	(but with a different extension). The transformation is accessible through the file manager; see <i>Files Panel</i> (page 58) for details. When a configuration is loaded on the sensor, the associated transformation is automatically loaded together with it. <b>Current Configuration</b> is typically used when the sensor's position relative to the object scanned is always changing, e.g., when the sensor is mounted on a robot arm moving to different scanning locations.

## Alignment vs. Travel Calibration

The table below summarizes the differences between alignment calibration and travel calibration.

### *Alignment Calibration vs. Travel Calibration*

	Alignment Calibration	Travel Calibration
<b>Target Type</b>	Flat surface or calibration bar	Calibration disk or calibration bar
<b>Target/Sensor Motion</b>	Stationary	Linear motion
<b>Calibrates Tilt</b>	Yes	Yes
<b>Calibrates Z axis Offset</b>	Yes	Yes
<b>Calibrates X axis Offset</b>	Yes (Calibration bar required)	Yes
<b>Calibrates Encoder</b>	No	Yes
<b>Calibrates Travel Speed</b>	No	Yes

See *Coordinate Systems* (page 44) for definitions of coordinate axes. See *Calibration Targets* (page 26) for descriptions of calibration disks and bars.

The procedures to perform alignment calibration or travel calibration are described in the next sections. After calibration, the coordinate system for laser profiles will change from sensor coordinates to system coordinates.

## Alignment Calibration

Alignment calibration can be used to compensate for mounting inaccuracies by aligning sensor data to a common reference surface (often a conveyor belt).

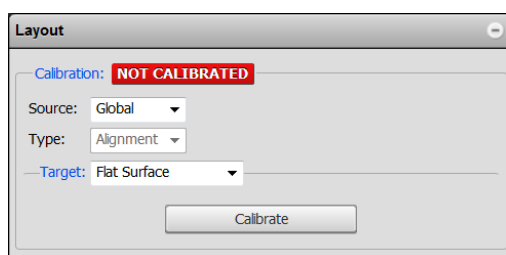

*To perform alignment calibration:*

1. Ensure that all sensors have a clear view of the target surface. Remove any irregular objects from the sensor's field of view that might interfere with alignment calibration. If using a calibration bar for a dual-sensor system, ensure that the lasers illuminate a

reference hole on the calibration bar.

2. Navigate to the **Layout** panel and select **Global** or **Current Configuration** as the **Source**.  
Click the arrow button next to **Calibration** to expand the panel. See *Transformation Sources* (page 79) for details on transformation sources.
3. Select **Alignment Calibration** as the **Type**.
4. Clear the previous calibration if present.  
Press the **Clear Calibration** button to remove an existing calibration.
5. Select a calibration **Target**.  
Select **Flat Surface** to use the conveyor surface (or other flat surface) as the calibration reference, or **Bar** to use a custom calibration bar. If using a calibration bar, specify the bar dimensions and reference hole layout. See *Calibration Targets* (page 26) for details.
6. Place the target under the sensor.
7. Press the **Calibrate** button.  
The sensors will start, and the alignment calibration process will take place. Calibration is performed simultaneously for all sensors. If the sensors do not calibrate, check and adjust the exposure settings.

 Alignment calibration uses the exposure defined for the single exposure mode, regardless of the current exposure mode

8. Use **Profile** mode to inspect calibration results.  
Laser profiles from all sensors should now be aligned to the calibration target surface. The base of the calibration target (or target surface) provides the origin for the system Z axis.

 Alignment calibration does not automatically calibrate the resolution of the encoder (if present) or the travel speed. However, these values can be manually entered if desired. See *Trigger Panel* (page 64) for more information.

 When using a calibration bar, there can be at most one hole in each sensor's field of view.

## Travel Calibration

Travel calibration can be used to achieve alignment calibration and motion calibration in a single procedure.

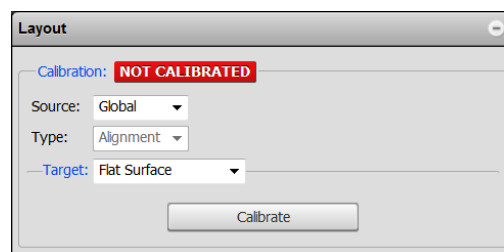

*To perform travel calibration:*

1. Place the calibration target before the laser plane.

Remove other objects from the transport system so that the calibration target is the only object that is scanned.

2. Navigate to the Layout panel and select **Global** or **Current Configuration** as the **Source**.  
Click the arrow button next to Calibration to expand the panel.
3. Select **Travel Calibration** as the **Type**.
4. Select a calibration **Target**.  
Select one of the **Disk** options to use a standard disk target or **Bar** to use a custom-made calibration bar. If using a calibration bar, specify the bar dimensions and reference hole layout. See *Calibration Targets* (page 26) for details.
5. Press the **Calibrate** button.  
The sensors will start and then wait for the calibration target to pass through the laser plane.

 Travel calibration uses the exposure defined for single exposure mode, regardless of the current exposure mode.

6. Engage the transport system.  
When the calibration target has passed completely through the laser plane, the calibration process will complete automatically. To properly calibrate the travel speed, the transport system must be running at the production operating speed before the target passes through the laser plane.
7. Use Profile mode to inspect calibration results.  
Laser profiles from all sensors should now be aligned to the calibration target surface. The base of the calibration target (or target surface) provides the origin for the system Z axis.

 When using a calibration bar, there can be at most one hole in each sensor's field of view. If a disk is used for calibrating a dual-sensor setup in a wide layout, half of the disk must be in each sensor's field of view.

## Clearing Calibration

*To clear calibration:*

1. Navigate to the **Calibration** panel on the **Setup** page.
2. Select whether to clear the Global or the Current Configuration transformation source.
3. Click the **Calibration** or **Clear Calibration** button.  
If the **Clear Calibration** button is pressed, the calibration will be erased and sensors will revert to using sensor coordinates.

## Filters Panel

The **Filters** panel can be used to post-process a profile before it is output or is used by measurement tools.

The following types of filters are supported:

Filter	Description
X Resampling Interval	Configures resampling interval size to balance between CPU loading, output data rate, and X resolution.
Smoothing	Applies moving window averaging to reduce random noise in a profile.
Gap Filling	Fills in missing data caused by occlusions using information from the nearest neighbors.

## Smoothing

Smoothing works by substituting a profile result with the average value of itself and its nearest neighbors. Smoothing can be applied along the X axis or the Y axis. X smoothing works by calculating a moving average across samples within the same profile. Y smoothing works by calculating a moving average in the direction of travel at each X location.

If both X and Y smoothing are enabled, the data is smoothed along X axis first, then along the Y axis.

*To configure X smoothing:*

1. Select Profile or Part mode.
2. Navigate to the **Filters** panel.  
Click the arrow next to **Smoothing** to expand the panel.
3. Enable X Smoothing and select the window value.  
The window value represents the averaging window size along the X axis.
4. Check that the laser profiling is satisfactory.

*To configure Y smoothing:*

1. Select Profile or Part mode.
2. Navigate to the **Filters** panel.  
Click the arrow next to **Smoothing** to expand the panel.
3. Enable Y Smoothing and select the window value.  
The window value represents the averaging window size along the Y axis.
4. Check that the laser profiling is satisfactory.

## Gap Filling

Gap filling works by filling in missing data points using the lowest values from the nearest neighbors. The sensor can fill gaps along both the X axis and the Y axis. X gap filling works by filling in the gaps within the same profile. Y gap filling works by filling in gaps in the direction of travel at each X location.

If both X and Y gap filling are enabled, missing data is filled along the X axis first, then along the Y axis.

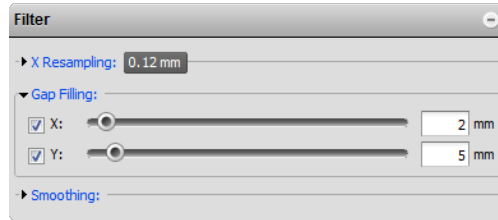

### To configure X gap filling:

1. Select Profile or Part mode.
2. Navigate to the **Filters** panel.  
Click the arrow next to **Gap Filling** to expand the panel.
3. Enable **X gap filling** and select the maximum width value.  
The maximum gap value represents the maximum gap width that the Gocator will fill. Gaps wider than the maximum width will not be filled.
4. Check that the laser profiling is satisfactory.

### To configure Y gap filling::

1. Select Profile or Part mode.
2. Navigate to the Filters panel.  
Click the arrow next to **Gap Filling** to expand the panel.
3. Enable Y gap filling and select the maximum width value.  
The maximum gap value represents the maximum gap width that the Gocator will fill. Gaps wider than the maximum width will not be filled.
4. Check that the laser profiling is satisfactory.

## X Resampling Interval

Resampling interval is the spacing between data points in a resampled profile; see *Resampled and Raw Profile Format* (page 45) for details. A larger interval creates profiles with lower X resolution but reduces CPU usage and potentially increases the maximum frame rate. A larger interval also reduces the data output rate.

By default, the Gocator outputs data at the medium resolution.

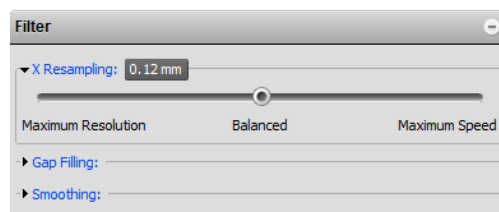

To configure the X resampling interval:

1. Select Profile or Part mode.
2. Navigate to the **Filter** panel.  
Click the arrow next to **X Resampling** to expand the panel.
3. Select a resampling interval level.
  - Maximum Speed: Use the lowest X resolution within the active area as the resampling interval. This setting minimizes CPU usage and data output rate but the profile has the lowest X resolution (i.e., least detail).
  - Balanced: Use the X resolution at the middle of the active area as the resampling interval. This setting balances CPU load, data output rate and the X resolution.
  - Maximum Resolution: Use the highest X resolution within the active area as the resampling interval. This setting maximizes resolution but has higher CPU load and has the highest data output rate (i.e., greatest detail).

## Detection Panel

In Part mode, the Gocator sensor analyzes each profile to identify discrete objects. Part measurements can then be performed on each discrete object.

Part detection can be performed when the trigger source is set to **Time** or **Encoder**. To use the **Time** trigger source, the travel speed must be calibrated. To use the Encoder trigger source, the encoder resolution must be calibrated. See *Travel Calibration* (page 81) for more information.

Multiple parts can pass through the laser at the same time and will be individually tracked. Parts can be separated along the laser line (X axis), in the direction of travel (Y axis), or by gated external input.

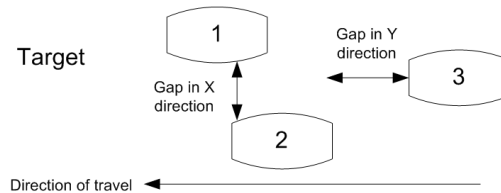

The following settings can be tuned to improve the accuracy and reliability of part detection.

Detection	
Height Threshold:	<input type="text" value="5"/> mm
Threshold Direction:	Above <input type="button" value="v"/>
Gap Threshold:	<input type="text" value="10"/> mm
Area Threshold:	<input type="text" value="10"/> mm <sup>2</sup>
Maximum Length:	<input type="text" value="200"/> mm
Frame Of Reference:	Sensor <input type="button" value="v"/>

Setting	Description
Height Threshold	Determines the profile height threshold for part detection. The setting for Threshold Direction determines if parts should be detected above or below the threshold. Above is typically used to prevent the belt surface from being detected as a part when scanning

Setting	Description
	<p>objects on a conveyor.</p> <p>In an opposite layout, the threshold is applied to the difference between the top and the bottom profile. Target thinner than the threshold value is ignored, including places where only one of either top or bottom is detected.</p> <p>To separate part by gated external input, set the Height Threshold to the Active area Z offset (i.e., minimum Z position of the current Active Area), set the trigger source to Time or Encoder and check the Gate Using External Input check box.</p>
Threshold Direction	Determines if parts should be detected above or below the Height Threshold.
Gap Threshold	Determines the minimum separation between objects in the XY plane. If parts are closer than the gap interval, they will be merged into a single part.
Area Threshold	Determines the minimum area for a detected part. Set this value to a reasonable minimum in order to filter out small objects or noise.
Maximum Length	Determines the maximum length of the part object. When the object exceeds the maximum length, it is automatically separated into two parts. This is useful to break a long object into multiple sections and perform measurements on each section.
Frame of Reference	<p>Determines the coordinate reference for part measurements.</p> <p>When set to Sensor, all measurement values are relative to the sensor's Field of View in X and relative to the encoder zero position in Y.</p> <p>When set to Part, all measurements except Bounding Box X and Y are relative to the center of the bounding box of the part. For Bounding Box X and Y, the measurement values are always in the Sensor Frame of Reference.</p>

*To set up part detection:*

1. Navigate to the **Operation Mode** panel and select Part mode.
2. Navigate to the **Detection** panel.
3. Adjust the settings.

## Data Viewer

The data viewer can display video images, profile plots, height maps, and intensity images. It is also used to configure the active area (see page 69) and measurement tools (see page 94). The data viewer changes depending on the current operation mode and the panel that has been selected.

## Video Mode

In Video operation mode, the data viewer displays a camera image. In a dual-sensor system, camera images from the Main or the Buddy sensor can be displayed.

## Exposure Mode View

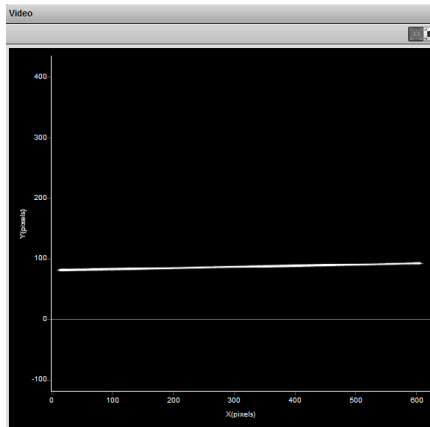

Exposure can be set to **Single**, **Dynamic**, or **Multiple**. For details on setting exposure, see page 71.

If the **Multiple** option is selected in the **Exposure** field in the **Sensor** panel, a second drop-down is displayed at the top of the data viewer. This drop-down lists the exposures that have been added. Choosing an exposure changes the view of the data viewer to that exposure.

If the **Single** or **Dynamic** option is selected in the **Exposure** field in the **Sensor** panel, the exposure drop-down will not be shown and only one exposure will be displayed.

*To select the view of the display:*

1. Go to the **Setup** page.
2. Choose **Video** mode in the **Operation Mode** panel.
3. Select the camera view.  
Select **Main** or **Buddy** from the first drop-down list next to **View** at the top of the data viewer.
4. Select the exposure.  
Select the exposure from the second drop-down list next to **View** at the top of the data viewer. This drop-down is only visible if the **Multiple** option has been selected.

To display a color exposure overlay on the video image to help set the correct exposure, check **Exposure Indication** at the top of the data viewer.

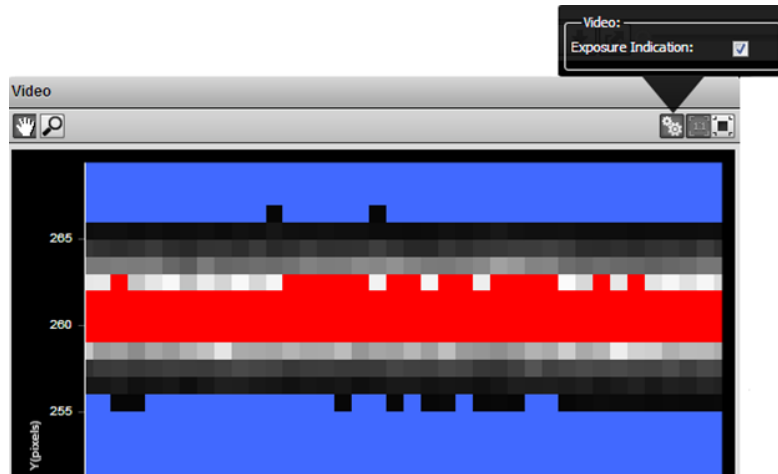

**Exposure Indication** uses the following colors:

- Blue: Indicates background pixels ignored by the sensor.
- Red: Indicates saturated pixels.

Correct tuning of exposure depends on the reflective properties of the target material and on the requirements of the application. Settings should be carefully evaluated for each application, but often a good starting point is to set the exposure so that there are 2 to 3 red pixels in the center of the laser line.

## Profile and Raw Mode

In Profile and Raw mode, the data viewer displays profile plots.

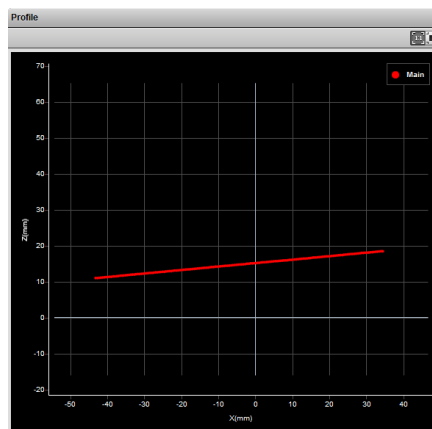

In a dual-sensor system, profiles from individual sensors or from a combined view can be displayed. When in the **Setup** page, selecting a panel (e.g., **Sensor** or **Layout** panel) automatically sets the display to the most appropriate display view.

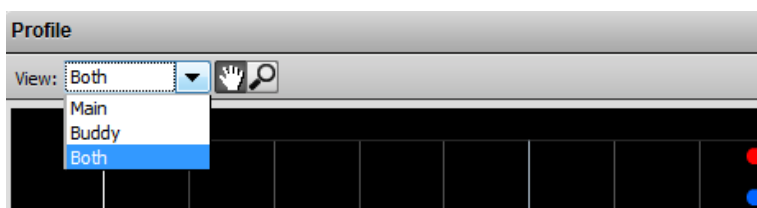

To manually select the display view in the Setup Page:

1. Go to the Setup page.
2. Select the view in the data viewer.  
The view of an individual sensor or the combined view of two sensors can be selected from the drop-down list at the top of the data viewer.

In the **Measurement** page, the view of the display is set to the profile source of the selected measurement tool.

## Whole Part Mode

In Whole Part operation mode, the data viewer can display height maps and intensity images of the detected objects. You can select the data to display from the **View** option.

Clicking on the **3D** button displays Whole Part data in the 3D viewer. The 3D model is overlaid with the information that corresponds to the selected **View** option.

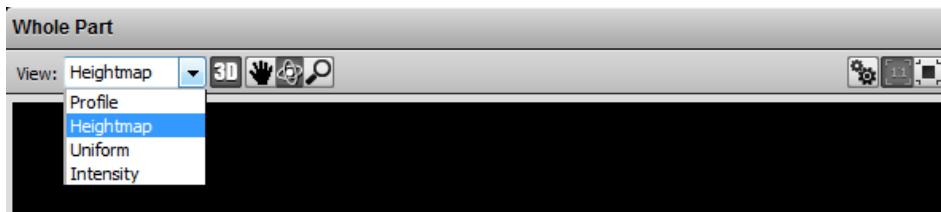

View Option	Information
Profile	Plots the last collected profile. (Only available in 2D view.)
Heightmap	In 2D view, displays the pseudo color height map. In 3D view, overlays the 2D pseudo color height map on the 3D model.
Uniform	Overlays a uniform shaded surface on the 3D model. (Only available in 3D view.)
Intensity	In 2D view, displays the intensity. In 3D view, overlays the intensity map on the 3D model. <b>(Acquire Intensity must be checked in the Operation Mode panel.)</b>

Choosing the Profile view option will switch the data viewer out of the 3D viewer and display the profile plot.

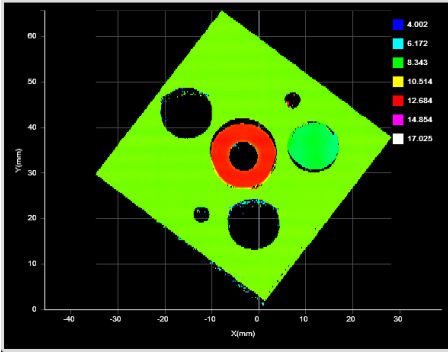

2D viewer for height map

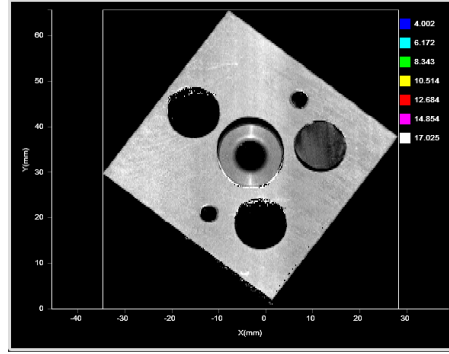

2D viewer for intensity

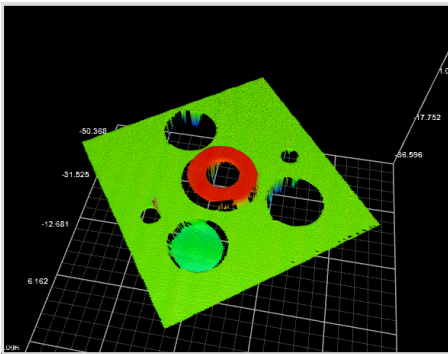

3D viewer with height map overlay

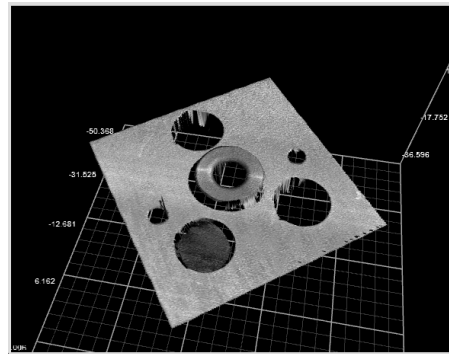

3D viewer with intensity overlay

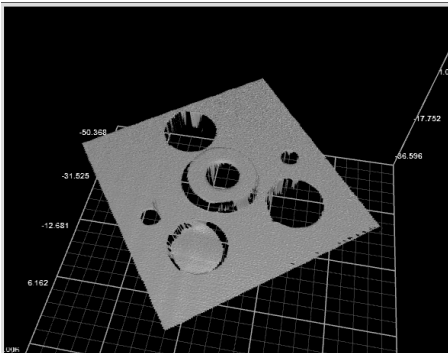

3D viewer with uniform overlay

Clicking on the **3D** button toggles between the 2D and 3D viewer. See *Data Viewer Controls* (next page) for explanations on the available controls.

In a dual-sensor system, data from individual sensors or from a combined view can be selected. While in the Setup Page, selecting a panel (e.g., Sensor, Layout, or Detection panel) will automatically set the display to the most appropriate display type and display view.

To manually select the display type and the display view in the Setup page:

1. Go to the Setup page.
2. Select the View options in the data viewer.  
**Profile, Heightmap, Uniform, or Intensity** can be selected from the left drop-down list. The view from an individual sensor or the combined view of two sensors can be selected from the right drop-down list.

## Region Definition

Regions, such as an active area or a measurement region, can be graphically set up using the data viewer.

When the Setup page is active, the data viewer can be used to graphically configure the active area. The Active Area setting can also be configured manually by entering values into its fields and is found in the **Sensor** panel see page 69.

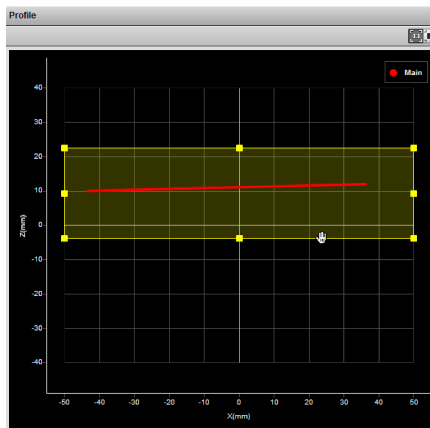

To set up a region of interest:

1. Move the mouse cursor to the rectangle.  
The rectangle is automatically displayed when a setup or measurement requires an area to be specified.
2. Drag the rectangle to move it, and use the handles on the rectangle's border to resize it.

## Data Viewer Controls

The data viewer is controlled by mouse clicks and by the buttons on the display toolbar. The mouse wheel can also be used for zooming in and out.

Press 'F' when the cursor is in the data viewer to switch to full screen.

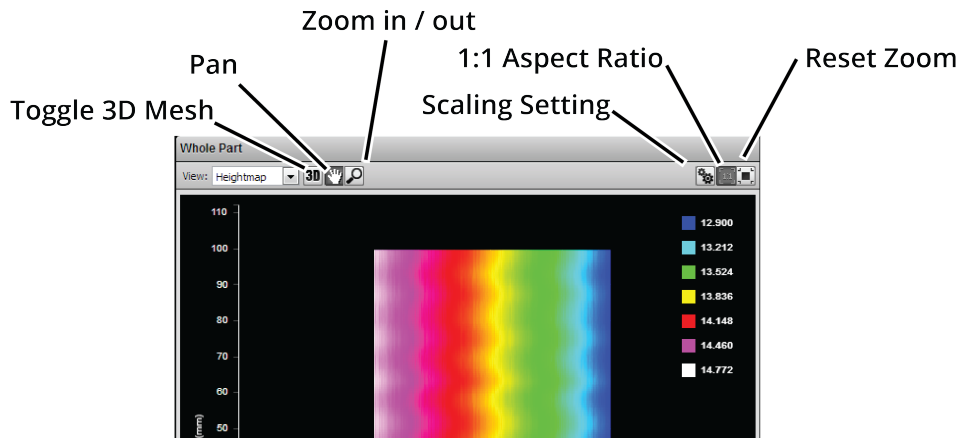

## Height Map Color Scale

Height maps are displayed in pseudo-color; the height (Z) axis is color-coded. The scaling of the height map can be adjusted.

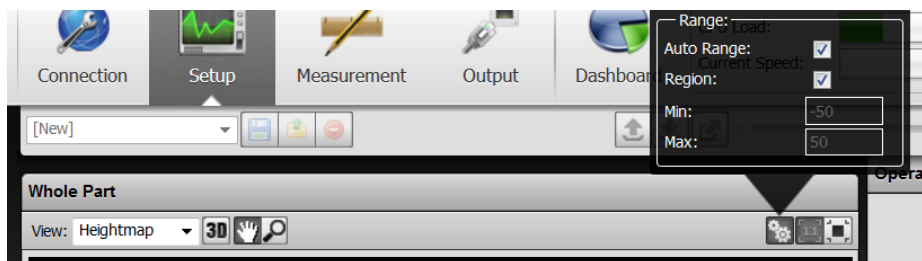

To change the scaling of the height map:

1. Select **Heightmap** from the drop-down in the data viewer.
2. Click the Scaling button.

### Range options

- a. To automatically set the scale, check the **Auto Range** checkbox in the range scaling dialog box that is displayed.
- b. To manually set the scale, uncheck the **Auto Range** checkbox, and then enter the minimum and maximum height to which the colors will be mapped.

### Sub-region options

- a. To auto-scale the color scale based on a user-selected sub-region of the heightmap, check the **Region** option and adjust the yellow region box in the data viewer to the desired location and size.

## Intensity Output

Gocator sensors can produce intensity images that measure the amount of light reflected by an object. An 8-bit intensity value is output for each range value along the laser line. Gocator applies the same coordinate system and resampling logic as the ranges to the intensity values.

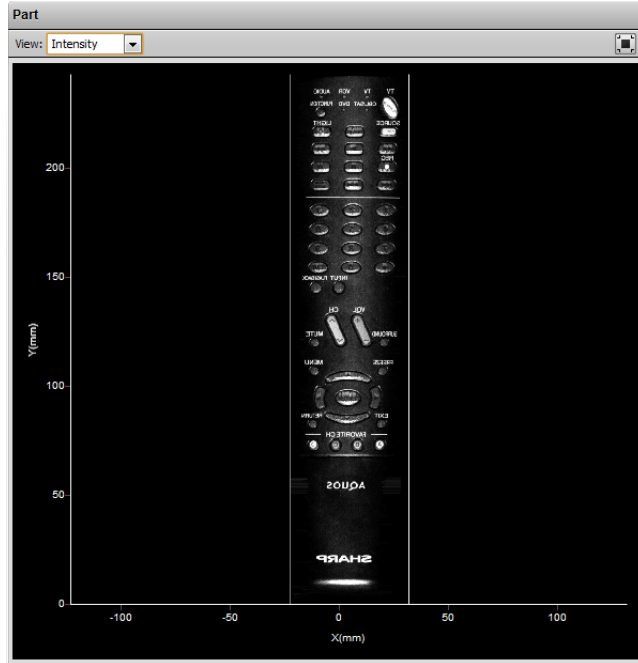

# Measurement

The following sections describe the Gocator's tools and measurements.

## Measurement Page Overview

Tools and their measurements are added and configured using the **Measurement** page.

The content of the **Measurement** page is controlled by the current operation mode. In Profile mode, the **Measurement** page displays tools for profile measurement. In Part Mode, the Measurement page displays tools for part measurement. The **Measurement** page is disabled in Video and Raw mode.

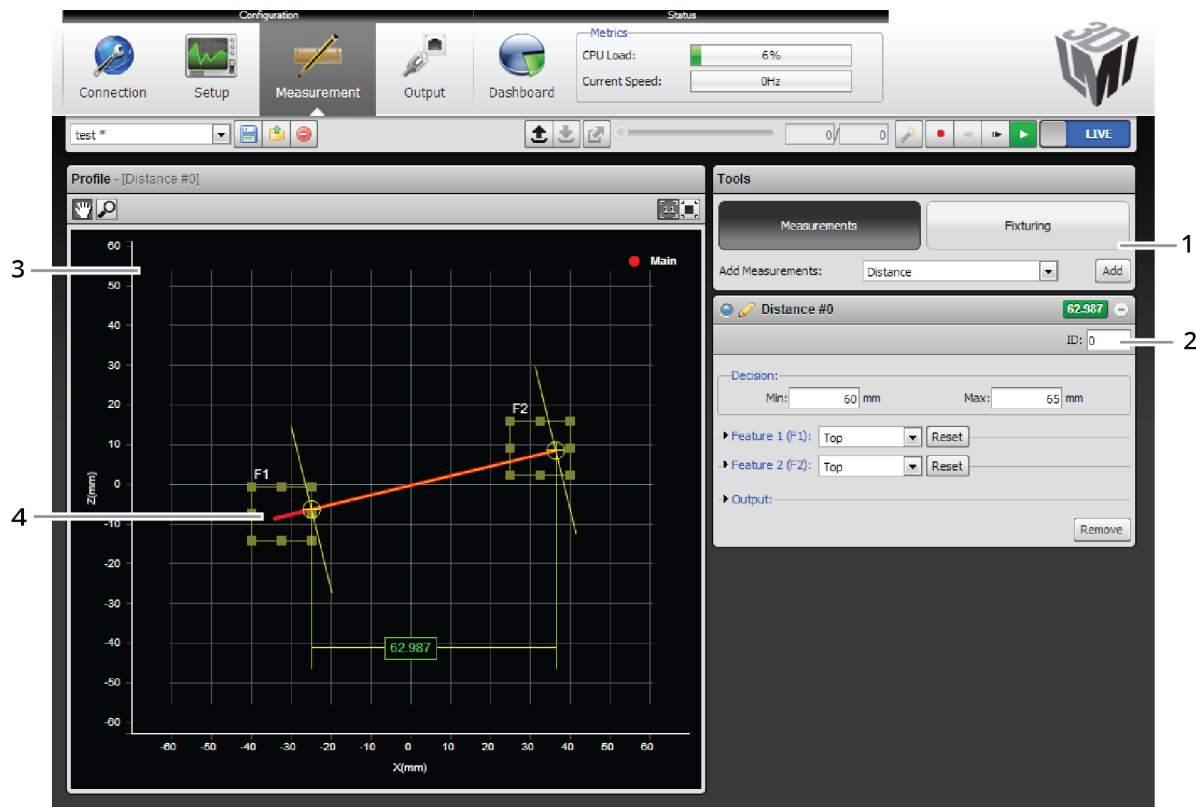

Element	Description
1 Tools Panel	Use the <b>Tools</b> panel to add new measurements or to configure fixturing. See <i>Tools Panel</i> (next page).
2 Measurement Panel	For each measurement that is added, a configuration area will appear below the <b>Measurements</b> panel. Use this area to adjust settings for the measurement.
3 Data Viewer	Displays profile or part data, sets up tools, and displays result calipers related to the selected measurement. Parts are displayed using a height map, which is a top-down view of the XY plane, where color represents height. See <i>Data Viewer</i> (page 97).
4 Feature Area	Configurable region of interest from which feature points are detected. These feature points are used to calculate the measurements. The number of feature areas displayed depends on which measurement tool is currently selected.

## Tools Panel

The following sections describe the **Tools** panel.

### Adding and Removing Measurements

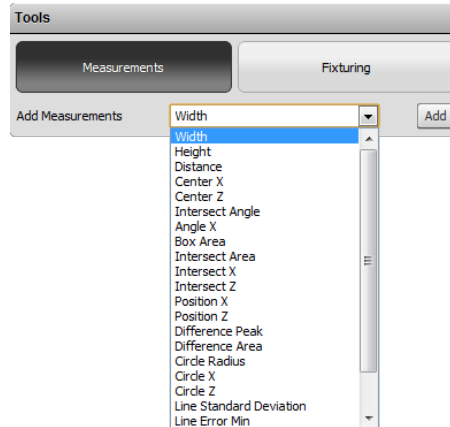

*To add a measurement:*

1. Select the desired measurement type.  
Click on the item in the drop-down list next to **Add Measurements** to select the measurement type.
2. Press the **Add** button.  
A configuration panel for the new measurement will be added to the bottom of the stack.

*To remove a measurement:*

1. Select the desired measurement.  
Click on the title bar of the measurement to select it.
2. Click the **Remove** button.  
The measurement will be removed from the list of measurements.



If the **Add Measurement** list contains only the Distance measurement, then the sensor is not equipped with profile tools. The Distance measurement is provided in all sensors to demonstrate the measurement capability.

### Profile Fixturing

Profile fixturing is used to track the movement of parts along the laser line (X axis and Z axis). The movement is calculated as an offset and is used to correct the positions of the feature areas. This ensures that the regions of interest used to detect features are correctly positioned for every part.

Profile fixturing is not required in order to use measurements. This is an optional feature intended to make measurements more robust when the X position and the height of the target vary from target to target.

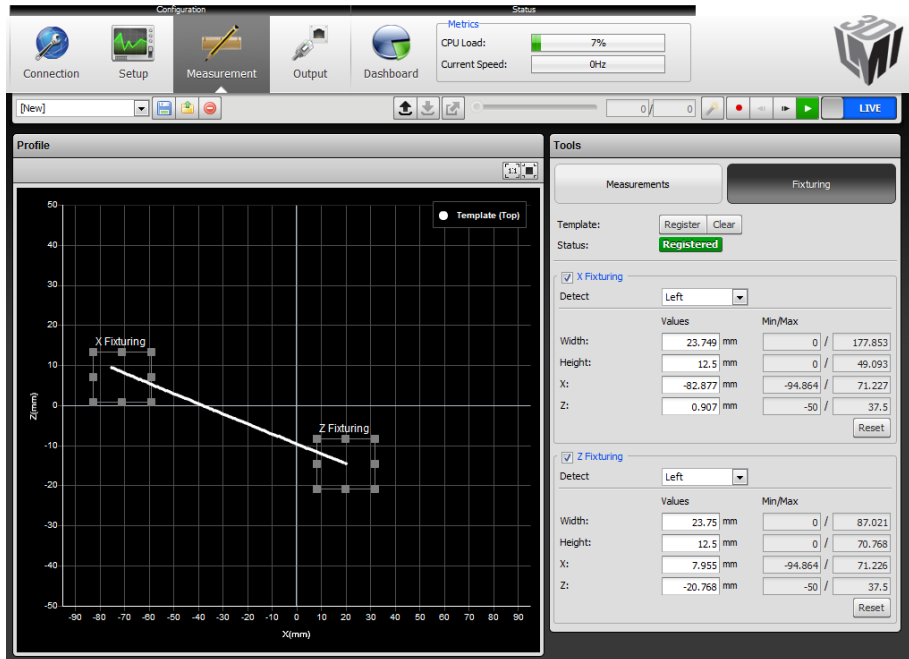

A profile template is needed for fixturing to work. The profile template is the reference used to calculate the profile movement along the X axis and Z axis. A profile template includes a detection area (white rectangles in the picture above) and the type of feature point to detect within the area. When the profile template and the live profile falls into the area, the movement is calculated by computing the difference between the positions of the feature point of the profile template and the live profile.

#### *To register a profile template:*

1. Place a representative target in the field of view.  
The target should be similar to the objects that will later be measured. Use the **Start** or **Snapshot** buttons to view live profile data while positioning the target.
2. Click the Register button.  
A snapshot of the target object will be captured and set as the current profile template. The profile template is shown in white within the data viewer.  
After a profile is registered, fixturing for the X axis and Z axis can be configured independently.

After a profile is registered, fixturing for the X axis and the Z axis can be configured independently.

#### *To set up profile fixturing in the X axis:*

1. Press the Fixturing button in the Measurement panel.
2. Enable X Fixturing.  
Check the **X Fixturing** box to enable fixturing for the X axis.
3. Adjust the detection area.  
Profile data within the detection area will be used to calculate the feature point for fixturing.
4. Select an feature point type.

Select the feature point type from the **Detect** drop-down box. The point type determines how the feature point is calculated from the profile data within the detection area.

*To set up profile fixturing in the Z axis with a new template:*

1. Click on the **Fixturing** button in the **Measurement** panel.
2. Enable Z Fixturing.  
Check the **Z Fixturing** box to enable fixturing for the Z axis.
3. Adjust the detection area.  
Profile data within the detection area will be used to calculate the feature point for fixturing.
4. Select a feature point type.  
Select the feature point type from the **Detect** drop-down box. The point type determines how the feature point is calculated from the profile data within the detection area.

When profile fixturing is used, you should set up the measurement's areas to match with the profile template. The profile template is hidden when the sensor is running. When the sensor is stopped and the user is viewing the Measurement page, the profile template will be automatically reloaded in the data viewer.

*To clear a registered profile template:*

1. Press the Fixturing button in the Measurements panel.
2. Click the Clear button.

Changes to profile fixturing and the template are temporary until they are saved. See *Saving and Loading Settings* (page 47) for details on how to save changes.

## Data Viewer

Regions, such as active area or measurement regions, can be graphically set up using the data viewer in the 2D or in the 3D view.

When the **Measurement** page is active, the data viewer can be used to graphically configure measurement regions. Measurement regions can also be configured manually in measurements by entering values into the provided fields (see page 101).

For instructions on how to set up measurement regions graphically, see page 91.

## Measurement Management

### Measurement Name

Each measurement can be assigned a unique name. This allows multiple measurements of the same type to be distinguished in the Gocator web interface. The name is also referenced by the Script tool.



*To change a measurement name:*

1. Click on the measurement name.
2. Enter a new name.
3. Press the Tab key.

The name change will be completed when you press the Tab key or click outside of the name edit field.

## Measurement ID

Measurement ID is used to uniquely identify a measurement in the Gocator protocol or in the SDK. The value must be unique among all measurements.

*To edit a measurement ID:*

1. Select a measurement.  
Click on the + in a measurement panel to expand the panel.
2. Click on the measurement ID.
3. Enter a new number.  
The value must be unique among all measurements.

4. Press the Tab key.  
The name change will be completed when you press the Tab Key or click outside of the measurement ID edit field.

## Profile Sources

For dual-sensor systems, measurements must specify a profile source for tools. The profile source determines which sensor provides data for the measurement.

The following options are available:

Profile Source	Description
Main	Data is provided by the Main sensor. This is the only option for standalone systems.
Buddy	Data is provided by the Buddy sensor.
Both	Data is provided by the Main and the Buddy sensor.

*To select the source:*

1. Select a measurement.  
Click on the + in a measurement panel to expand it.
2. Select the source.  
The source drop-down list will not appear if **Main** is the only option.

## Measurement Tool Linking

Tool linking can be used to reduce CPU load when running multiple tools of the same type, using the same tool settings. For example, a Circle Radius tool can be linked with a Circle Z tool, but not with a Groove Z tool.

The following profile tools support linking within each group

- Circle Radius, Circle X, and Circle Z
- Line Standard Deviation, Line Error Min, Line Error Max, and Line Percentile
- Gap and Flush
- Groove X, Groove Z, Groove Width, and Groove Depth
- Strip X, Strip Z, Strip Width, and Strip Height

The following whole part tools support linking within each group:

- Volume and Area
- Bounding Box X, Bounding Box Y, Bounding Box Width, Bounding Box Height, and Bounding Box Angle
- Hole X, Hole Y, Hole Z, and Hole Radius
- Stud Tip X, Stud Tip Y, Stud Tip Z, Stud Base X, Stud Base Y, Stud Base Z, and Stud Radius
- Opening X, Opening Y, Opening Z, Opening Width, Opening Length, and Opening Angle
- Plane Angle X, Plane Angle Y, and Plane Offset Z
- Position X, Position Y, and Position Z
- Texture Roughness and Texture Invalid Count



*To link measurement tools:*

1. Add two or more measurement tools of the same type.
2. Configure the settings of one of the tools.  
This tool is considered the "master" tool, whose settings will be used by the linked tools.
3. In the Link drop-down list, select the master tool.  
This will cause the tool to use all settings of the master tool and the CPU will only be loaded with one instance of the tool.  
Repeat this step for any other tools you want to link to the master tool.

## Common Measurement Parameters

All measurements provide the following parameters: Decision, Region, and Output.

Many measurements also have tool-specific parameters or measurement-specific parameters (see page 94).

## Profile Sources

For dual-sensor systems, measurements must specify a profile source for tools. The profile source determines which sensor provides data for the measurement.

The following options are available:

Profile Source	Description
Main	Data is provided by the Main sensor. This is the only option for standalone systems.
Buddy	Data is provided by the Buddy sensor.
Both	Data is provided by the Main and the Buddy sensor.

To select the source:

1. Select a measurement.  
Click on the + in a measurement panel to expand it.
2. Select the source.  
The source drop-down list will not appear if **Main** is the only option.

## Decisions

Results from a measurement tool can be compared against minimum and maximum thresholds to generate pass / fail decisions. The decision state is pass if a measurement value is between the minimum and maximum threshold; in the user interface, these values are displayed in green. Otherwise, the decision state is fail; in the user interface, these values are displayed in red.

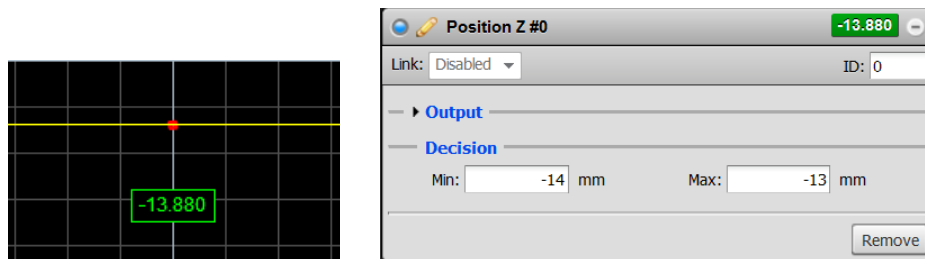

Value (-13.880) is within the decision thresholds (Min:-14, Max:-13). Decision: Pass

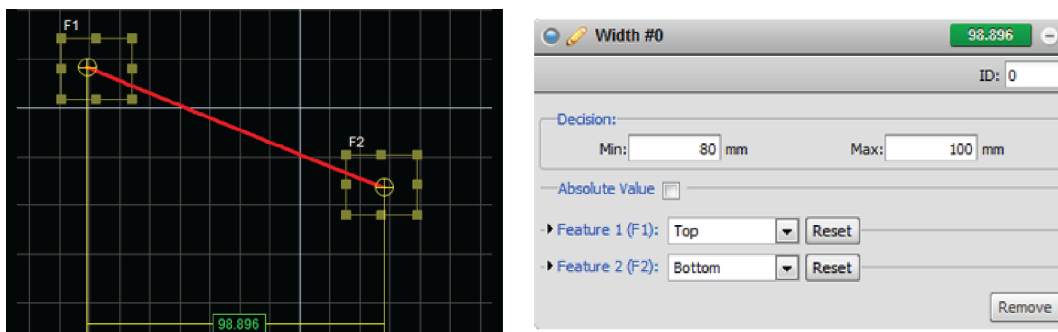

Value (50.380) is within the decision thresholds (Min: 80, Max:100). Decision: Pass



Position Z #0 -13.880

Link: Disabled ID: 0

► Output

Decision

Min:  mm Max:  mm

Value (30.200) is outside the decision thresholds (Min: 32, Max: 35). Decision: Fail

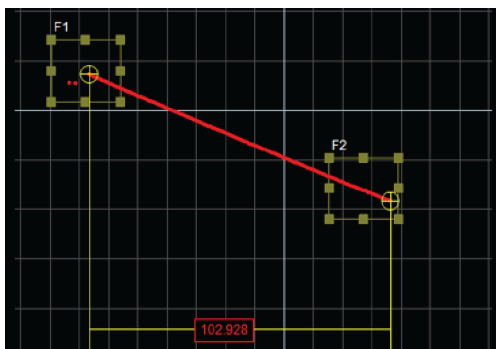

Width #0 102.928

ID: 0

Decision:

Min:  mm Max:  mm

Absolute Value

► Feature 1 (F1):

► Feature 2 (F2):

Value (102.928) is outside the decision thresholds (Min: 80, Max: 100). Decision: Fail

Along with measurement values, decisions can be sent to external programs and devices. In particular, decisions are often used with digital outputs to trigger an external event in response to a measurement. See *Output* (page 157) for more information on transmitting values and decisions.

## Regions

The Region parameter is used to limit the region in which a measurement will occur. See the individual tools for details on the best way to use this parameter with each tool.

The parameter can be configured graphically using the mouse in the data viewer when the **Measurement** page is active.

Some measurements use more than one region.

This parameter is also referred to as a measurement region.

*To configure regions:*

1. Select a measurement.  
Click on the + in a measurement panel to expand it.
2. Check the **Region** checkbox to enable a region.
3. Configure the region using the fields.  
You can also configure the region graphically using the mouse in the data viewer.

## Output Filters

Output filters can be applied to measurement values before they are output from the Gocator sensors.

Filter	Description
Scale and Offset	The Scale and Offset settings are applied to the measurement value according to the following formula: $\text{Scale} * \text{Value} + \text{Offset}$ Scale and Offset can be used to transform the output without the need to write a script. For example, to convert the measurement value from millimeters to thousands of an inch, set Scale to 39.37.
Hold Last Valid	Hold the last valid value when the measurement is invalid. Measurement is invalid if there is no valid value.
Smoothing	Apply moving window averaging to reduce random noise in a measurement output. The averaging window is configured in number of frames. If Hold Last Valid is enabled, smoothing uses the output of the Hold Last Valid filter.

To configure the output filters:

1. Select a measurement.  
Click on the + in a measurement panel to expand it. Click the arrow next to **Output** to expand the panel.
2. Enable filters and configure the settings.



## Profile Measurement

This section describes the profile tools and measurements available in sensors that are equipped with measurement tools.

Most measurement functions detect and compare *feature points* or *lines* found within laser profile data. Measurement *values* are compared against minimum and maximum thresholds to yield *decisions*.

## Feature Points

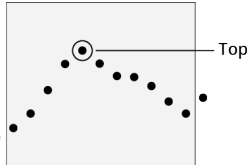
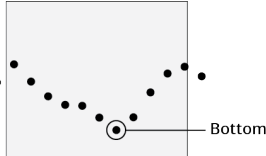
Many profile measurements involve estimating the locations of feature points and then making comparisons between the feature points. The following types of points can be identified.

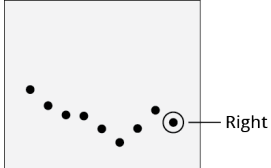
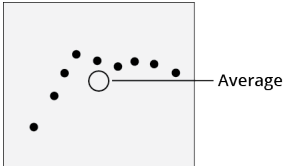
Point Type	Examples
<b>Top</b> Finds the point with the maximum Z value in the region of interest.	
<b>Bottom</b> Finds the point with the minimum Z value in the region of interest.	
<b>Left</b> Finds the point with the minimum X value in the region of interest.	
<b>Right</b> Finds the point with the maximum X value in the region of interest.	
<b>Average</b> Determines the average location of points in the region of interest.	

---

**Point Type****Examples****Corner**

Finds a dominant corner in the region of interest, where corner is defined as a change in profile slope.

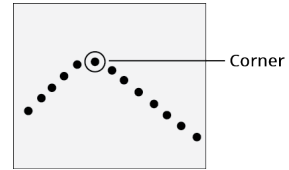
**Top Corner**

Finds the top-most corner in the region of interest, where corner is defined as a change in profile shape.

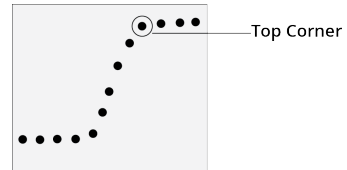
**Bottom Corner**

Finds the bottom-most corner in the region of interest, where corner is defined as a change in profile shape.

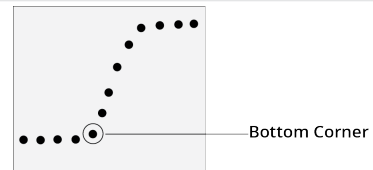
**Left Corner**

Finds the left-most corner in the region of interest, where corner is defined as a change in profile shape.

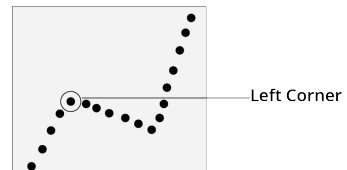
**Right Corner**

Finds the right-most corner in the region of interest, where corner is defined as a change in profile shape.

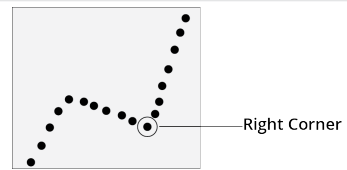
**Rising Edge**

Finds a rising edge in the region of interest.

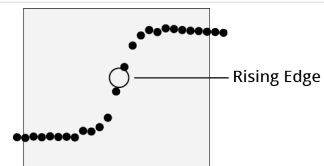
**Falling Edge**

Finds a falling edge in the region of interest.

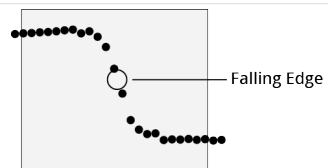

---

**Point Type****Examples****Any Edge**

Finds a rising or falling edge in the region of interest.

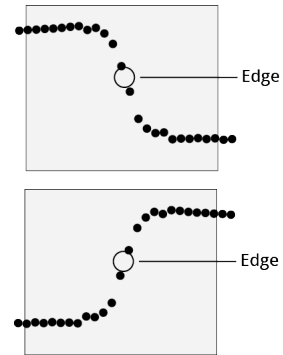
**Median**

Determines the median location of points in the region of interest.

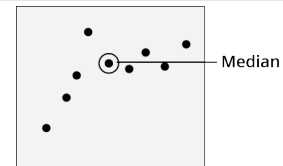

---

**Fit Lines**

Some measurements involve estimating lines in order to measure angles or intersection points. A fit line can be calculated using data from either one or two fit areas.

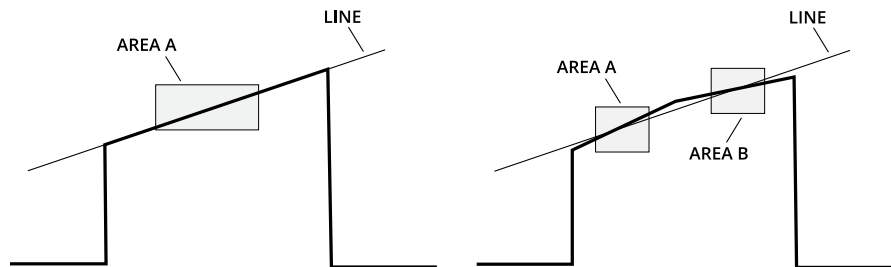

A line can be defined using one or two areas. Two areas can be used to bypass discontinuity in a line segment.

---

**Tools and Measurements****Width**

The Width tool determines the difference along the X axis between two feature points. The measurement value can be compared with minimum and maximum constraints to yield a decision.

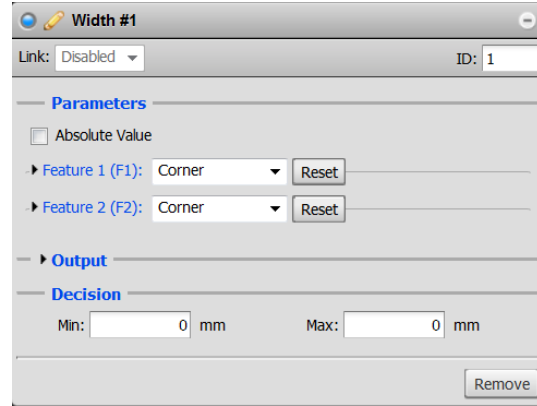
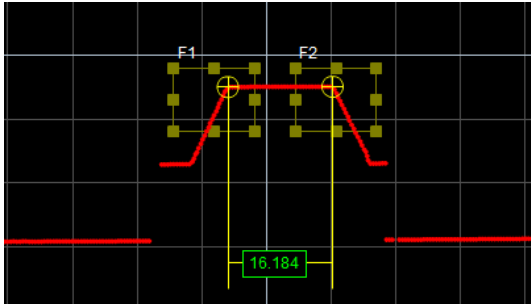

The difference can be calculated as an absolute or signed result. The difference is calculated by:

$$\text{Width} = \text{Feature 2}_{X \text{ position}} - \text{Feature 1}_{X \text{ position}}$$

#### Measurements

Measurement	Illustration
<p><b>Width</b></p> <p>Determines the difference along the X axis between two feature points.</p>	

#### Parameters

Parameter	Description
Absolute Value	Determines if the result will be expressed as an absolute or a signed value.
Decision	See <i>Decisions</i> (page 100).
Region	See <i>Regions</i> (page 101).
Output	See <i>Output Filters</i> (page 102).

### Height

The Height tool determines the difference along the Z axis between two feature points. The measurement value can be compared with minimum and maximum constraints to yield a decision.

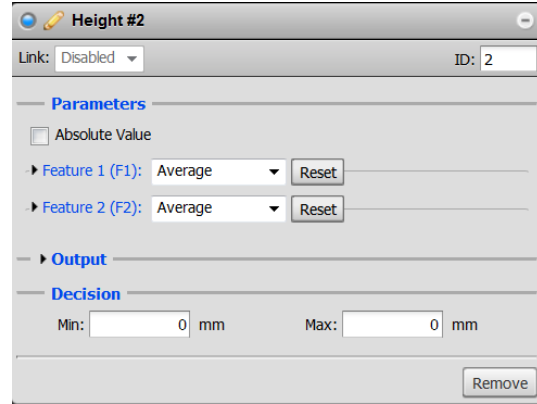
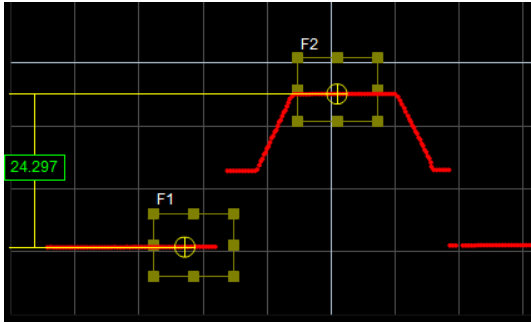

The difference can be expressed as an absolute or signed result. The difference is calculated by:

$$\text{Height} = \text{Feature 2}_{Z \text{ position}} - \text{Feature 1}_{Z \text{ position}}$$

The Height tool requires two feature points. See *Feature Points* (page 103) for information on point types and how to configure them.

#### Measurements

Measurement	Illustration
<p><b>Height</b></p> <p>Determines the difference along the Z axis between two feature points.</p>	
Parameters	
Parameter	Description
Absolute Value	Determines if the result will be expressed as an absolute or a signed value.
Decision	See <i>Decisions</i> (page 100).
Region	See <i>Regions</i> (page 101).
Output	See <i>Output Filters</i> (page 102).

#### Distance

The Distance tool determines the Euclidean distance between two feature points. The measurement value can be compared with minimum and maximum constraints to yield a decision.

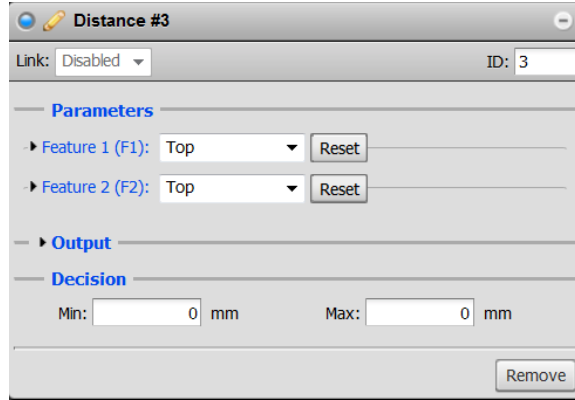
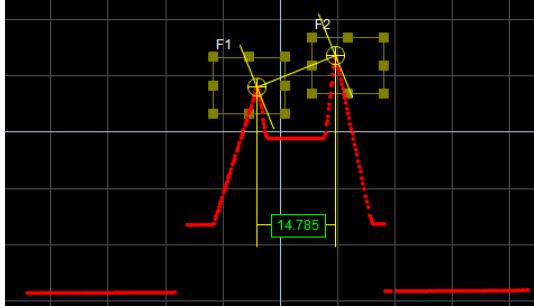

The Distance tool requires two feature points. See *Feature Points* (page 103) for information on point types and how to configure them.

*Measurements*

**Measurement**

**Illustration**

**Distance**

Determines the distance between two feature points.

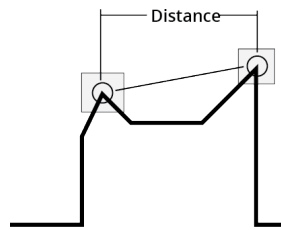

*Parameters*

**Parameter**

**Description**

Decision

See *Decisions* (page 100).

Region

See *Regions* (page 101).

Output

See *Output Filters* (page 102).

**Position**

The Position tool finds the X or Z axis position of a feature point. The measurement value can be compared with minimum and maximum constraints to yield a decision.

*Measurements*

**Measurement**

**Illustration**

**Position X**

Finds the X axis position of a feature.

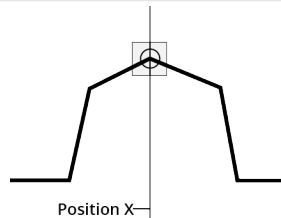

---

**Measurement****Position Z**

Finds the Z axis position of a feature.

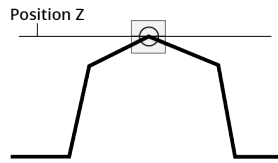
**Illustration**

---

*Parameters***Parameter****Description**

Decision

See *Decisions* (page 100).

Region

See *Regions* (page 101).

Output

See *Output Filters* (page 102).

---

**Center**

The Center tool finds the average location of two features points and measures the X or Z axis position of the average location. The measurement value can be compared with minimum and maximum constraints to yield a decision.

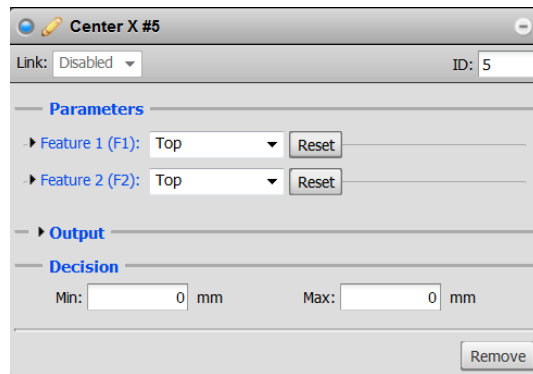
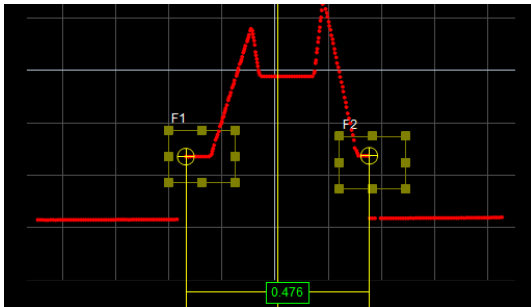

---

*Measurements***Measurement****Illustration****Center X**

Finds the average location of two features and measures the X axis position of the average location

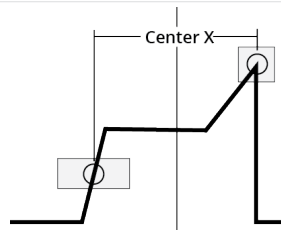
**Center Z**

Finds the average location of two features and measures the Z axis position of the average location.

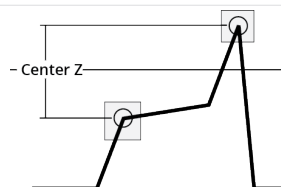

## Parameters

Parameter	Description
Decision	See <i>Decisions</i> (page 100).
Region	See <i>Regions</i> (page 101).
Output	See <i>Output Filters</i> (page 102).

## Angle

The Angle tool determines the angle between a fit line and the X axis. The measurement value can be compared with minimum and maximum constraints to yield a decision.

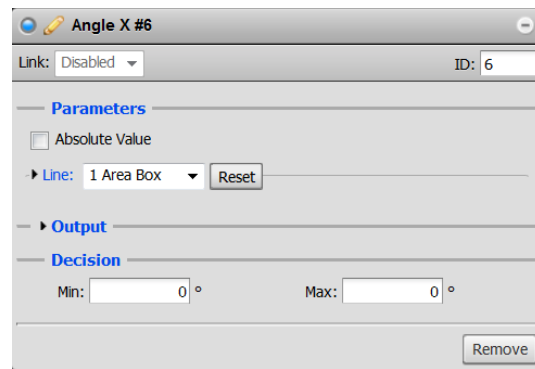
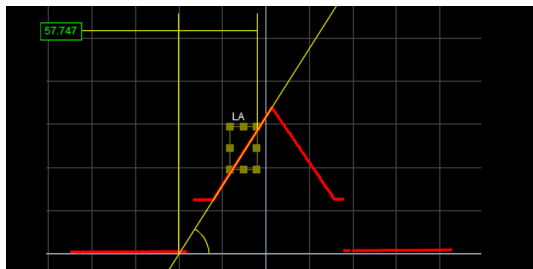

The angle can be expressed as a signed or an absolute result. The absolute result is used when the minimum and maximum constraints need to cover both positive and negative angles.

For a signed result, the angle is between -90 degrees and 90 degrees and is measured from the X axis. Positive angle is measured counter clockwise and negative angle is measured clockwise.

For an absolute result, the angle range is between 0 degrees and 90 degrees and is the absolute value of the angle between the line and the X axis.

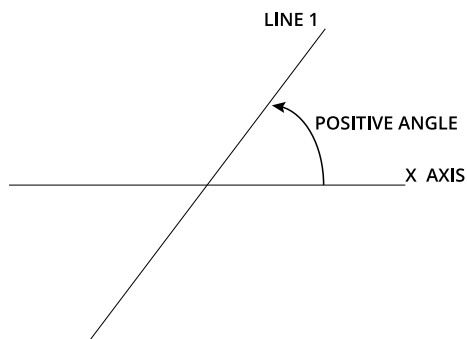

*When the angle of Line 1 is less than 90° clockwise from the X axis, the angle returned is positive.*

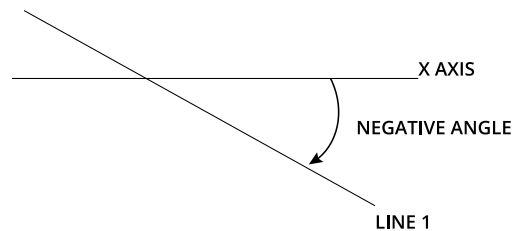

*When the angle of Line 1 is less than 90° counter clockwise from X axis, the angle returned is negative.*

## Measurements

### Measurement

### Illustration

#### Angle X

Fits a line to profile points within one or two areas and measures the angle between the fitted line and the X axis.

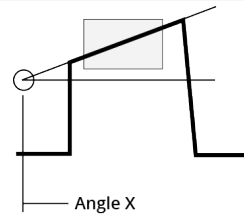

## Parameters

### Parameter

### Description

Absolute Value

Check the option for an absolute value. Uncheck it for a signed value.

Line

An Angle X measurement requires one fit line. One or two fit areas can be used for each fit line. See *Fit Lines* (page 105) for more information.

Decision

See *Decisions* (page 100).

Region

See *Regions* (page 101).

Output

See *Output Filters* (page 102).

## Intersect

The Intersect tool determines various characteristics related to intersect points and intersections. The measurement value can be compared with minimum and maximum constraints to yield a decision.

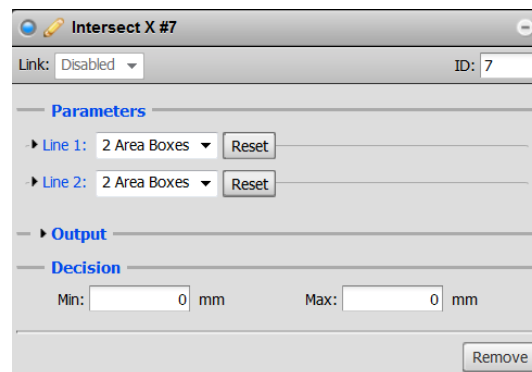

Measurements

Measurement

Illustration

**Intersect X**

Finds the intersection between two fitted lines and measures the X axis position of the intersection point.

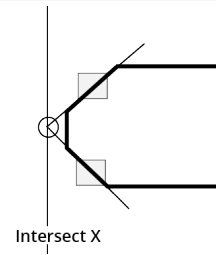

**Intersect Z**

Finds the intersection between two fitted lines and measures the Z axis position of the intersection point.

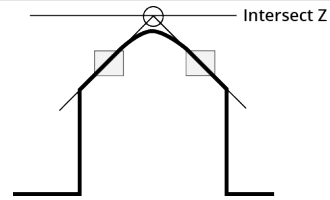

**Intersect Angle**

Finds the angle subtended by two fitted lines.

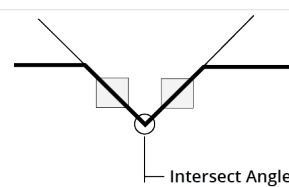

Parameters

Parameter

Description

Line

Intersect X, Z, and Angle measurements require two fit lines. One or two fit areas can be used for each fit line. See *Fit Lines* (page 105) for more information.

Absolute Value

*(Intersect Angle measurement only)*

Check the Absolute box to select absolute result. Uncheck for a signed result.

Decision

See *Decisions* (page 100).

Region

See *Regions* (page 101).

Output

See *Output Filters* (page 102).

**Area**

The Area tool determines the cross-sectional area within a region. The measurement value can be compared with minimum and maximum constraints to yield a decision.

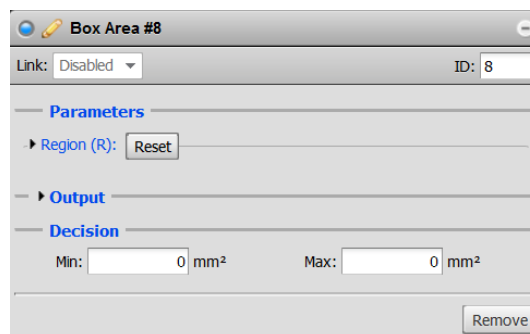
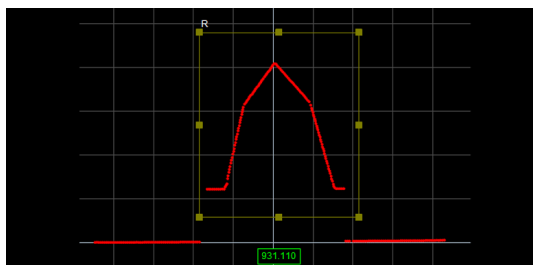

Areas are positive in regions where the profile is above the X axis. In contrast, areas are negative in regions where the profile is below the X axis.

*Measurements*

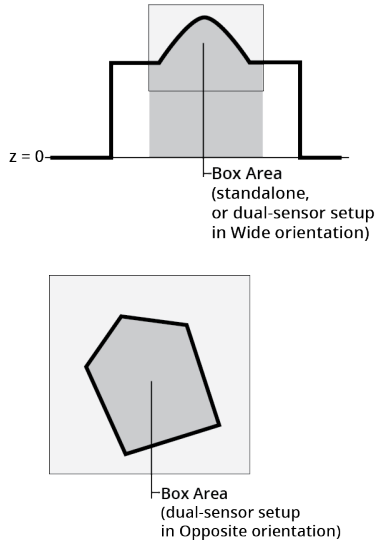
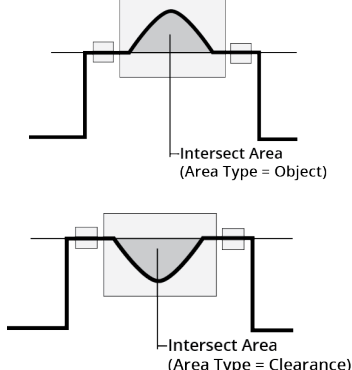
Measurement	Illustration
<p><b>Box Area</b></p> <p>Standalone sensor and dual-sensor setup (in Wide orientation): Measures the cross-sectional area within a region to the baseline at <math>z = 0</math>.</p> <p>Dual-sensor setup (in Opposite orientation): Measures the cross-sectional area bounded by the top and bottom profiles.</p> <p>See <i>Dual-Sensor System Layout</i> (page 77) for details on sensor orientations.</p>	
<p><b>Intersect Area</b></p> <p>Measures the cross-sectional area within a region that is above or below a fitted baseline.</p>	
<p><i>Parameters</i></p>	
Parameter	Description
<p>Area Type (<i>Intersect Area measurement only</i>)</p>	<p>Object area type is the area of regions above the baseline. Regions below the baseline are ignored. Clearance area type is the area of regions below the baseline (i.e., between profile and line). Regions above the baseline are ignored.</p>
<p>Baseline (<i>Intersect Area measurement only</i>)</p>	<p>Baseline is the user-defined fit line that represents the line above which (Object clearance type) or below which (Clearance area type) the cross-sectional area is measured.</p> <p>See <i>Fit Lines</i> (page 105) for more information on fit</p>

Parameter	Description
	lines.
Decision	See <i>Decisions</i> (page 100).
Region	See <i>Regions</i> (page 101).
Output	See <i>Output Filters</i> (page 102).

## Difference

The Difference tool provides measurements that determine the difference between a live profile and a template. The measurement value can be compared with minimum and maximum constraints to yield a decision.

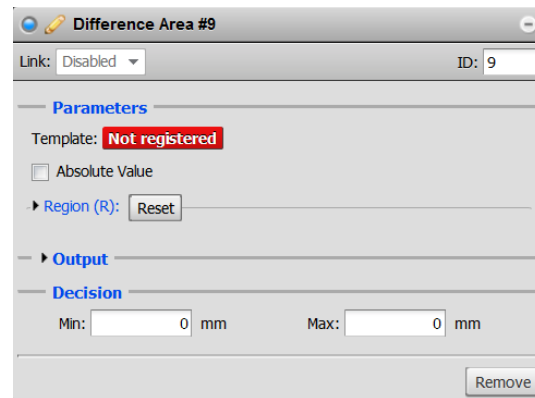
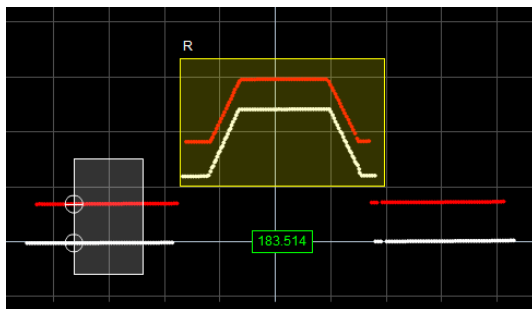

Area can be calculated as an absolute or signed value. Signed results are positive in regions where the live profile is closer to the sensors than the template. The illustrations below indicate the region where the results are positive and negative.

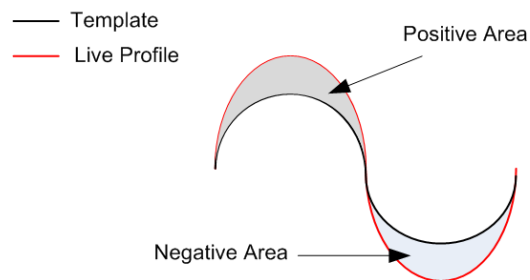

The result is the sum of all the areas within the measurement region.

When both the Main sensor and the Buddy sensor are selected in Opposite orientation, the calculation is applied to the thickness profiles of the live and template data. A thickness profile is calculated by subtracting the profile of the bottom sensor (i.e., the Buddy sensor) from the profile of the top sensor (i.e., the Main sensor).

The difference in peak can be calculated as an absolute or signed value. A signed difference is positive in regions where the live profile is closer to the sensors than the template. The illustrations below indicate the region where the results are positive or negative.

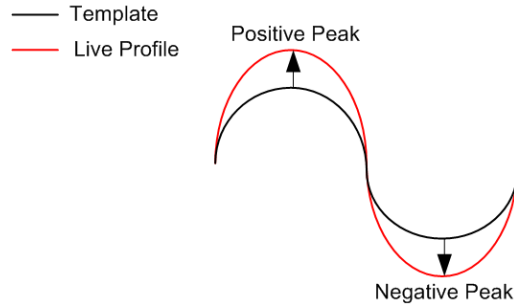

The result is the peak with the largest absolute value within region.

*Measurements*

Measurement	Illustration
<p><b>Difference Area</b></p> <p>Measures the difference in cross-sectional area between live profile and the template.</p>	
<p><b>Difference Peak</b></p> <p>Measures the maximum difference in height between the live profile and the template.</p>	

*Parameters*

Parameter	Description
Absolute Value	Check the Absolute box to select absolute result. Uncheck it to select a signed result.
Decision	See <i>Decisions</i> (page 100).
Region	The measurement region defines the zone in which cross-sectional area will be determined. See <i>Regions</i> (page 101) for more information.
Output	See <i>Output Filters</i> (page 102).

**Circle**

The Circle tool provides measurements that find the best-fitted circle to the live profile and measure various characteristics of the circle. The measurement value can be compared with minimum and maximum constraints to yield a decision.

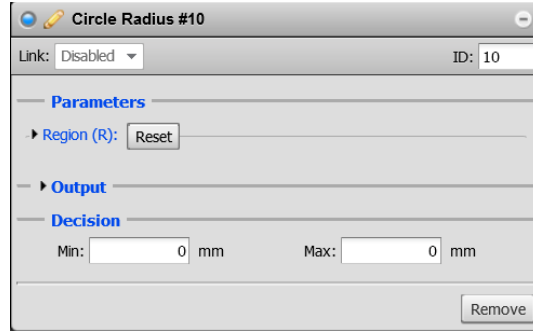
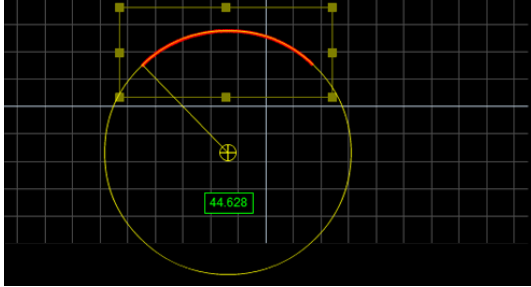

*Measurements*

**Measurement**

**Illustration**

**Circle Radius**

Measures the radius of the circle.

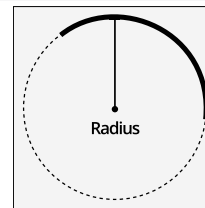

**Circle X**

Finds the circle center position in the X axis.

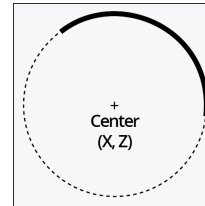

**Circle Z**

Finds the circle center position in the Z axis.

*Parameters*

**Parameter**

**Description**

Decision

See *Decisions* (page 100).

Region

See *Regions* (page 101).

Output

See *Output Filters* (page 102).

**Line**

The Line tool fits a line to the live profile and measures the deviations from the best-fitted line. The measurement value can be compared with minimum and maximum constraints to yield a decision.

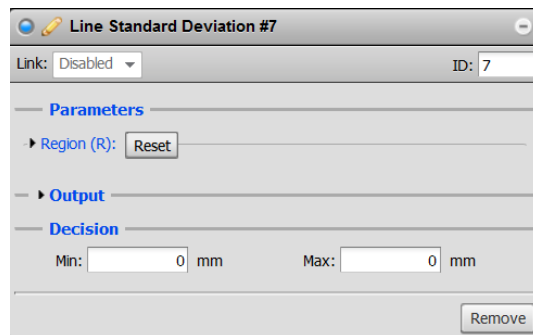
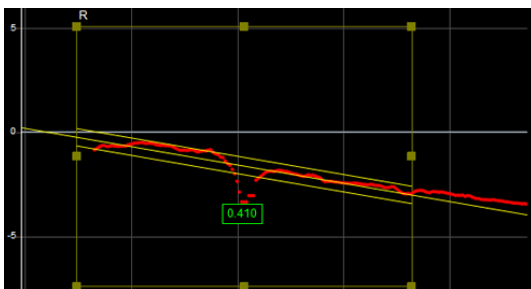

Measurements

Measurement	Illustration
<p><b>Standard Deviation</b></p> <p>Finds the best-fitted line and measures the standard deviation of the laser points from the best-fitted line.</p>	
<p><b>Line Error Min</b></p> <p>Finds the best-fitted line and measures the minimum error from the best-fitted line.</p>	
<p><b>Line Error Max</b></p> <p>Finds the best-fitted line and measures the maximum error from the best-fitted line.</p>	
<p><b>Line Percentile</b></p> <p>Finds the best-fitted line and measures the range (in Z) that covers a percentage of points around the best-fitted line.</p>	

Parameters

Parameter	Description
Decision	See <i>Decisions</i> (page 100).
Region	See <i>Regions</i> (page 101).
Output	See <i>Output Filters</i> (page 102).

**Gap and Flush**

This section describes the Gap and Flush tools, which share many parameters.

**Gap**

The Gap tool measures the distance between the edges of two surfaces. The measurement value can be compared with minimum and maximum constraints to yield a decision.

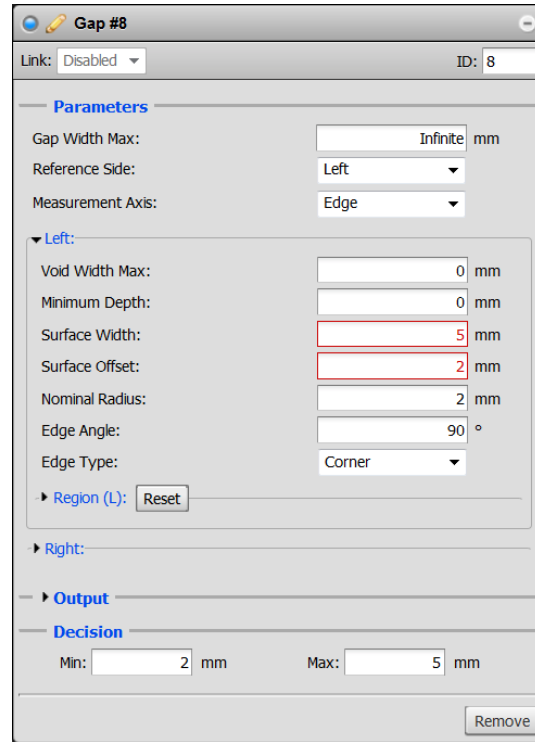
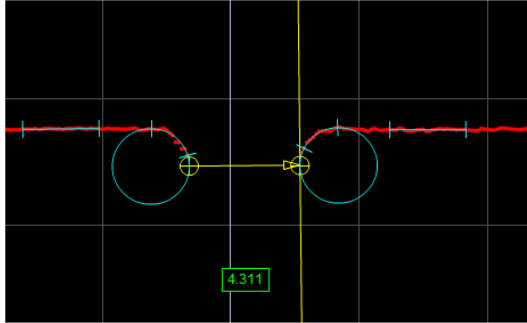

The Gap tool uses a complex feature-locating algorithm to find the gap and then return measurements. The behavior of the algorithm can be adjusted by changing the parameters in the measurement panel. See "Gap and Flush Algorithm" in the *Gocator Measurement Tool Technical Manual* for a detailed explanation of the algorithm and the parameters.

### Measurements

#### Measurement

##### Gap

Measures the distance between two surfaces. The surface edges can be curved or sharp.

#### Illustration

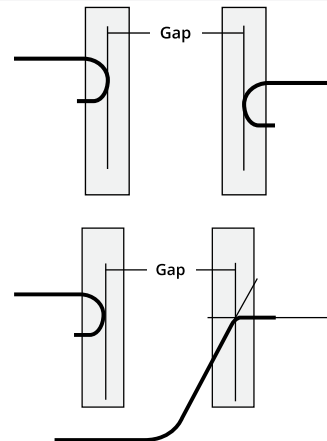

The Data Viewer displays the gap measurement in real time. It also displays the results from the intermediate steps in the algorithm.

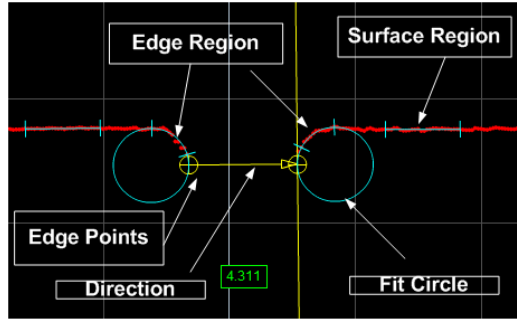

## Flush

The Flush tool measures the flushness between the edges of two surfaces. The measurement value can be compared with minimum and maximum constraints to yield a decision.

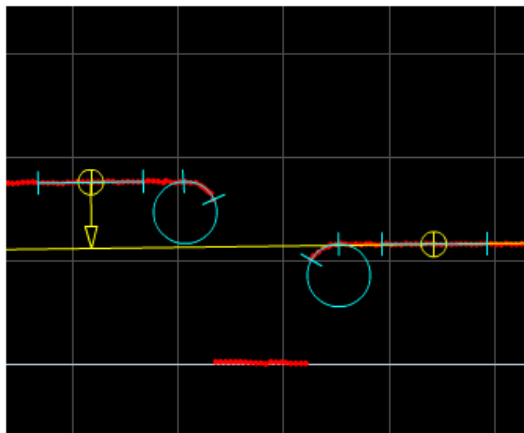

**Flush #9** ID: 9

Link: Disabled

---

**Parameters**

Gap Width Max:  mm

Reference Side:

▼ Left:

Void Width Max:  mm

Minimum Depth:  mm

Surface Width:  mm

Surface Offset:  mm

Nominal Radius:  mm

Edge Angle:  °

Edge Type:

▶ Region (L):

▶ Right:

▶ Output

---

**Decision**

Min:  mm Max:  mm

The Flush tool uses a complex feature-locating algorithm to find the flushness of the object it is being used on and then return measurements. The behavior of the algorithm can be adjusted by changing the parameters in the measurement panel. See "Gap and Flush Algorithm" in the *Gocator Measurement Tool Technical Manual* for a detailed explanation of the algorithm.

### Measurements

#### Measurement

#### Flush

Measures the flushness between two surfaces. The surface edges can be curved or sharp.

#### Illustration

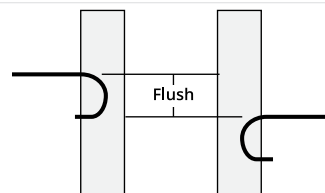

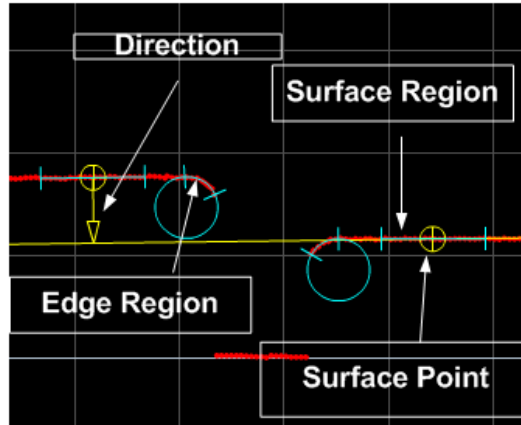

The Data Viewer displays the flush measurement in real time. It also displays the results from the intermediate steps in the algorithm.

### Groove

The Groove tool provides measurements of V-shape, U-shape, or open-shape grooves. The measurement value can be compared with minimum and maximum constraints to yield a decision.

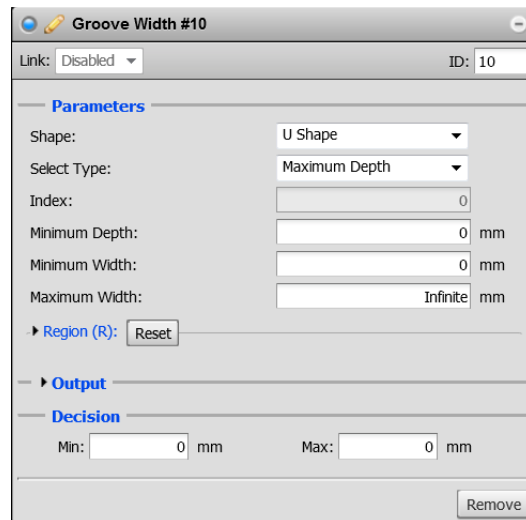
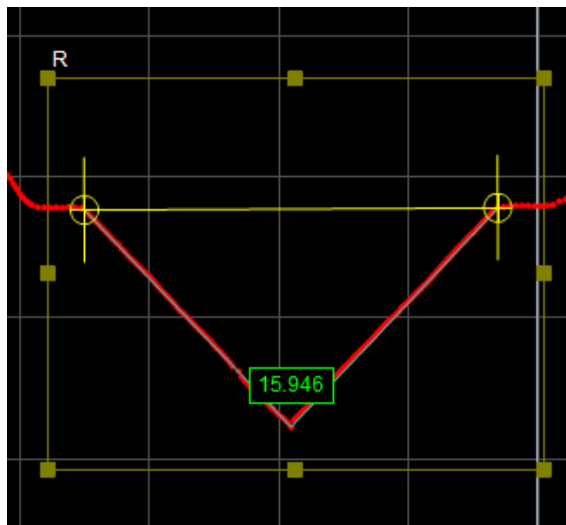

The Groove tool uses a complex feature-locating algorithm to find a groove and then return measurements. See "Groove Algorithm" in the *Gocator Measurement Tool Technical Manual* for a detailed explanation of the algorithm. The behavior of the algorithm can be adjusted by changing the parameters in the measurement panel.

Measurements

**Measurement**

**Illustration**

**Groove Width**

Measures the width of a groove.

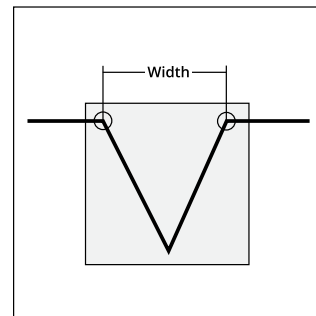
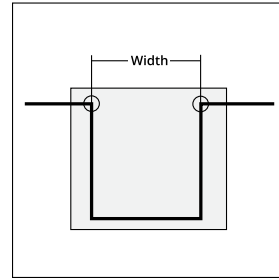

**Groove Depth**

Measures the depth of a groove as the maximum perpendicular distance from a line connecting the edge points of the groove.

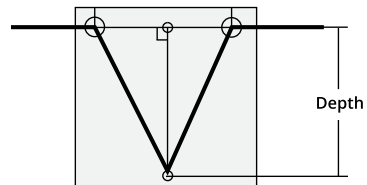
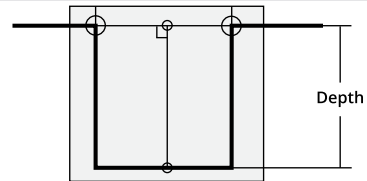

**Groove X**

Measures the X position of the bottom of a groove.

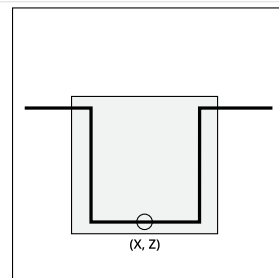

---

**Measurement****Illustration****Groove Z**

Measures the Z position of the bottom of a groove.

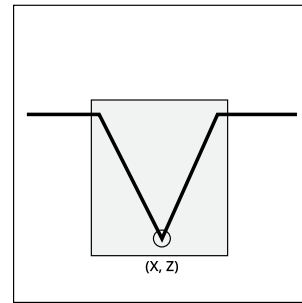

---

**Parameters****Parameter**      **Description**

Shape      Shape of the groove

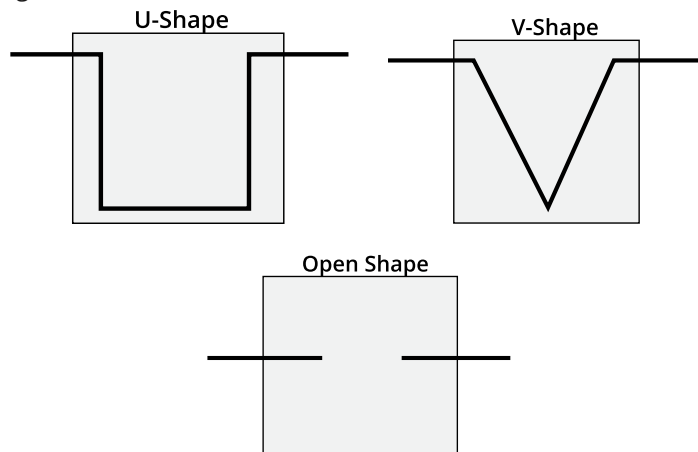

Location  
(Groove X and Groove Z measurements only)

Specifies the location type to return  
Bottom - Groove bottom. For a U-shape and open-shape groove, the X position is at the the centroid of the groove. For a V-shape groove, the X position is at the intersection of lines fitted to the left and right sides of the groove. See algorithm section below for more details.  
Left - Groove's left corner.  
Right - Groove's right corner.

Select Type      Specifies how a groove is selected when there are multiple grooves within the measurement area.

Maximum Depth - Groove with maximum depth.

Index from The Left - 0-based groove index, counting from left to right

Index from the Right - 0-based groove index, counting from right to left.

Index      0-based groove index.

Minimum Depth      Minimum depth for a groove to be considered valid.

Minimum Width      Minimum width for a groove to be considered valid. The width is the distance between the groove corners.

Maximum Width      Maximum width of a groove to be considered valid. If set to 0, the maximum is set to the width of the measurement area.

---

Parameter	Description
Decision	See <i>Decisions</i> (page 100).
Region	The measurement region defines the region in which to search for the groove. For a stable measurement, the measurement region should be made large enough to cover some laser data on the left and right sides of the groove. See <i>Regions</i> (page 101).
Output	See <i>Output Filters</i> (page 102).

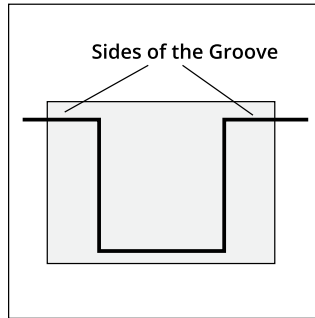

## Strip

The Strip tool measures the width of a strip. The measurement value can be compared with minimum and maximum constraints to yield a decision.

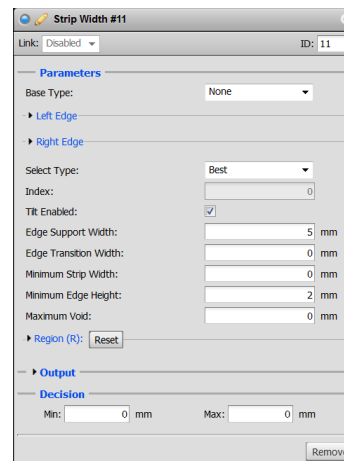
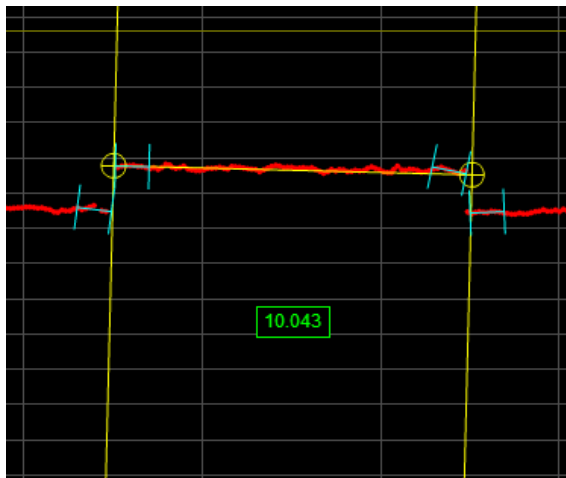

The Strip tool uses a complex feature-locating algorithm to find a strip and then return measurements. See "Strip Algorithm" in the *Gocator Measurement Tool Technical Manual* for a detailed explanation of the algorithm. The behavior of the algorithm can be adjusted by changing the parameters in the measurement panel.

*Measurements*

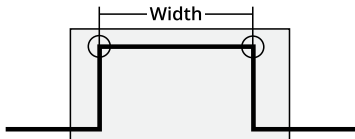
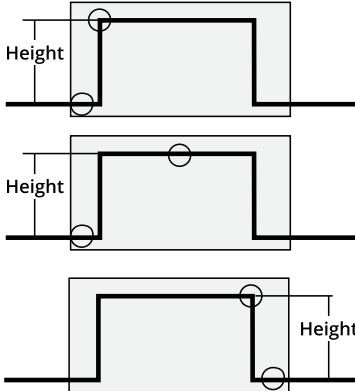
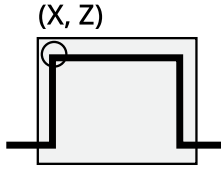
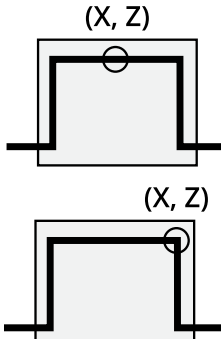
Measurement	Illustration
<p><b>Strip Width</b> Measures the width of a strip.</p>	
<p><b>Strip Height</b> Measures the height of a strip.</p>	
<p><b>Strip X</b> Measures the X position of a strip.</p>	
<p><b>Strip Z</b> Measures the Z position of a strip.</p>	

*Parameters*

Parameter	Description
Base Type	Affects detection of rising and falling edges.

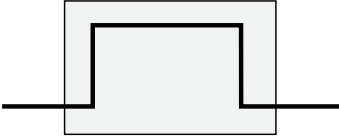
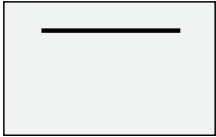
Parameter	Description
	<div style="text-align: center;"> <p><b>Base Type = Flat</b></p>  <p><b>Base Type = None</b></p>  </div> <p>When Base Type is set to Flat, both strip (raised area) and base support regions are needed. When set to None, only a point that deviates from a smooth strip support region is needed to find a rising or falling edge.</p>
Location <i>(Strip Height, Strip X, and Strip Z measurements only)</i>	Specifies the strip position from which the measurements are performed. Left - Left edge of the strip. Right - Right edge of the strip. Center - Center of the strip.
Left Edge	Specifies the features that will be considered as the strip's left edge. You can select more than one condition. Rising - Rising edge detected based on the strip edge parameters. Falling - Falling edge detected based on the strip edge parameters. Data end - First valid profile data point in the measurement region. Void - Gap in the data that is larger than the maximum void threshold. Gaps connected to the measurement region's boundary are not considered as a void. See "Strip Start and Terminate Conditions" in the <i>Gocator Measurement Tool Technical Manual</i> for the definitions of these conditions.
Right Edge	Specifies the features that will be considered as the strip's right edge. You can select more than one condition. Rising - Rising edge detected based on the strip edge parameters. Falling - Falling edge detected based on the strip edge parameters. Data end - Last valid profile data point in the measurement region. Void - Gap in the data that is larger than the maximum Void parameter. Gaps connected to the measurement region's boundary are not considered as a void. See "Strip Start and Terminate Conditions" in the <i>Gocator Measurement Tool Technical Manual</i> for the definitions of these conditions.
Select Type	Specifies how a strip is selected when there are multiple strips within the measurement area. Best - The widest strip. Index from The Left - 0-based strip index, counting from left to right Index from the Right - 0-based strip index, counting from right to left

Parameter	Description
Index	0-based strip index.
Minimum Edge Height	Specifies the minimum deviation from the strip base. See "Strip Step Edge Definitions" in the <i>Gocator Measurement Tool Technical Manual</i> on how this parameter is used for different base types.
Edge Support Width	Specifies the width of the region around the edges from which the data is used to calculate the step change. See "Strip Step Edge Definitions" in the <i>Gocator Measurement Tool Technical Manual</i> on how this parameter is used by different base types.
Edge Transition Width	Specifies the nominal width needed to make the transition from the base to the strip. See "Strip Step Edge Definitions" in the <i>Gocator Measurement Tool Technical Manual</i> on how this parameter is used by different base types.
Maximum Void	The maximum width of missing data allowed for the data to be considered as part of a strip when 'Void' is selected in the Left or Right Edge parameter. This value must be smaller than the Edge Support Width.

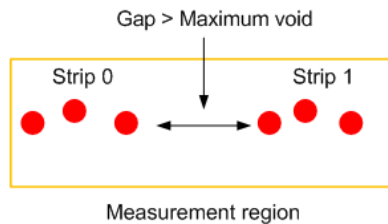

When occlusion and exposure causes data drops, users should use the gap filling function to fill the gaps. See *Gap Filling* (page 83) for information.

Minimum Strip Width	Specifies the minimum width for a strip to be considered valid.
Tilt	Enables/disables tile correction.
Decision	See <i>Decisions</i> (page 100).
Region	The measurement region defines the region in which to search for the strip. If possible, the region should be made large enough to cover the base on the left and right sides of the strip.

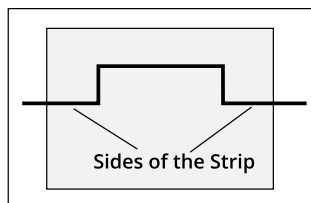

See *Regions* (page 101) for more information.

Output	See <i>Output Filters</i> (page 102).
--------	---------------------------------------

## Tilt

The strip may be tilted with respect to the sensor's coordinate X axis. This could be caused by conveyor vibration. If the Tilt option is enabled, the tool will report the width and height measurements following the tilt angle of the strip.

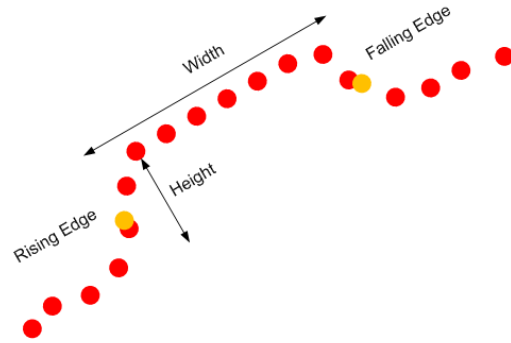

## Script

A Script measurement can be used to program a custom measurement using a simplified C-based syntax. A script measurement can produce multiple measurement values and decisions for the output.

See *Adding and Removing Measurements* (page 95) for instructions on adding measurements.

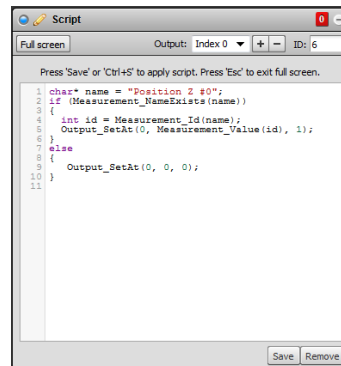

See *Script Measurement* (page 152) for more information on the script syntax.

*To create or edit a Script measurement:*

1. Add a new Script measurement or select an existing Script measurement.
2. Edit the script code.
3. Choose the number of desired script outputs using the + and - buttons.  
For each script output that is added, an index will be added to the **Output** drop-down and a unique ID will be generated.
4. Click the **Save** button to save the script code.  
If there is a mistake in the script syntax, the result will be shown as a "invalid" with a red border in the data viewer when you run the sensor.  
Outputs from multiple measurement tools can be used as inputs to the script. A typical script would take results from other measurement tools using the value and decision function, and output the result using the output function. Stamp information, such as time and encoder stamps, are available in the script, whereas the actual profile data is not. The script engine is not powerful enough to process the profile data itself. Only one script can be created.

## Whole Part Measurement

Whole part measurement involves capturing a sequence of laser profiles, identifying discrete objects, and measuring properties of those objects, such as the volume of the object or the height at a certain position of the object. All volumetric tools have the ability to operate either on the full object or within a region of interest at a certain position in relation to the object.

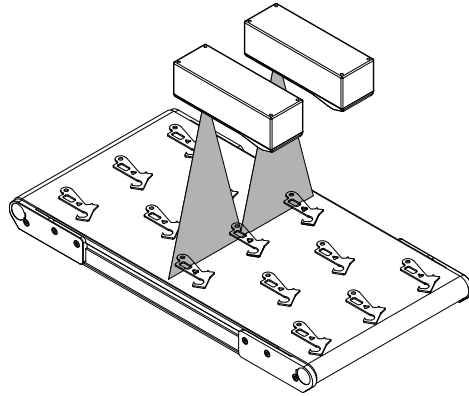

Multiple measurements can be performed on each part, limited only by the available CPU resources.

The frame of reference for the coordinate system of the detected object can be set to **Sensor** or **Part** in the Detection panel (see page 85). This setting determines what coordinate system the region of interest for a measurement is positioned in, as well as the coordinate reference used to output measurement values.

For example, if you need to measure the average height in a certain location relative to the sensor's FOV regardless of the objects passing under the sensor, the frame of reference should be set to **Sensor**. This is typical in applications where a wide web of material is continuously scanned, such as paper, rubber, fabrics, etc. If on the other hand you need to measure the average height in a certain location of a scanned object, the frame of reference should be set to **Part**. This is typical in applications where discrete objects pass under the sensor and specific locations on the objects need to be inspected.



Bounding Box Y is always reported relative to the encoder zero position (or relative to time 0 in case of time triggered Whole Part acquisition).

## Tools and Measurements

### Volume

The Volume tool determines the volume of a part. The measurement value can be compared with minimum and maximum constraints to yield a decision. See *Adding and Removing Measurements* (page 95) for instructions on adding measurements.

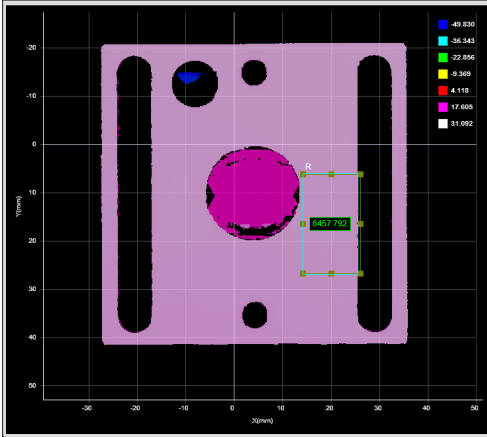

2D View

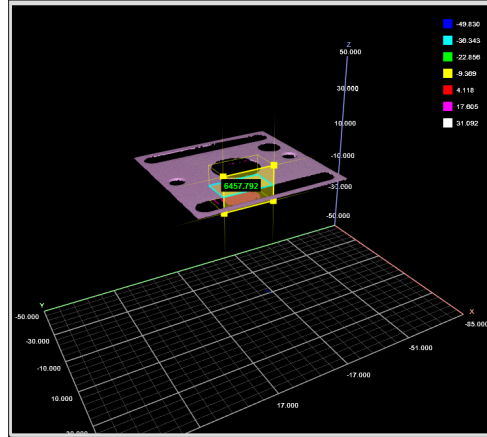

3D View

**Volume #3** 6457.792

Link: Disabled ID: 3

---

**Parameters**

Region (R): Reset

X: <input type="text" value="14.196"/> mm	Width: <input type="text" value="11.847"/> mm
Y: <input type="text" value="6.121"/> mm	Length: <input type="text" value="20.693"/> mm
Z: <input type="text" value="21.471"/> mm	Height: <input type="text" value="14.326"/> mm

---

**Output**

---

**Decision**

Min:  mm<sup>3</sup>    Max:  mm<sup>3</sup>

Remove

Measurement Panel

### Measurements

#### Measurement

#### Volume

Measures volume in XYZ space.

#### Illustration

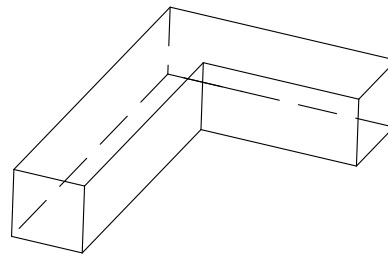

### Parameters

#### Parameter

#### Description

Decision

See *Decisions* (page 100).

Region

See *Regions* (page 101).

Output

See *Output Filters* (page 102).

## Area

The Area tool provides a measurement of the area of an object's surface in the XY plane. The measurement value can be compared with minimum and maximum constraints to yield a decision. See *Adding and Removing Measurements* (page 95) for instructions on adding measurements.

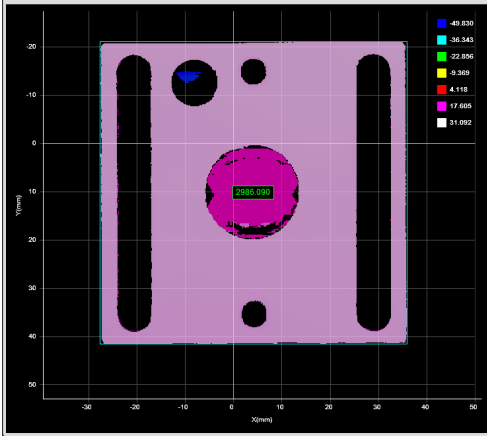

2D View

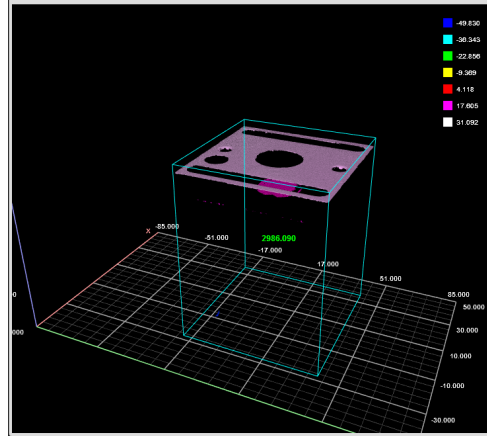

3D View

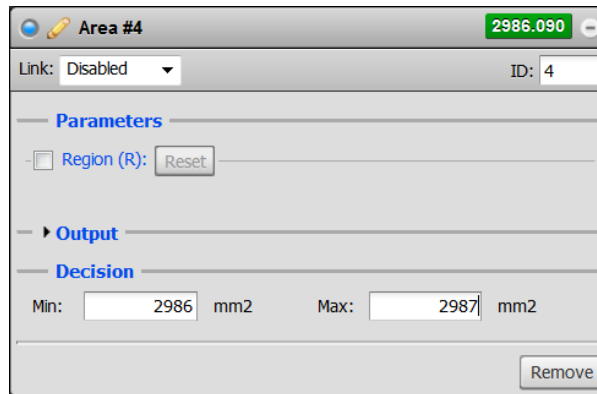

The Measurement Panel for 'Area #4' shows a value of 2986.090. It includes a 'Link' dropdown set to 'Disabled', an 'ID' field with the value '4', and a 'Parameters' section with a 'Region (R):' field and a 'Reset' button. The 'Output' section is expanded, showing a 'Decision' section with 'Min:' and 'Max:' fields, both containing the value '2987' and the unit 'mm2'. A 'Remove' button is located at the bottom right of the panel.

Measurement Panel

## Measurements

### Measurement

#### Area

Measures area in the XY plane.

### Illustration

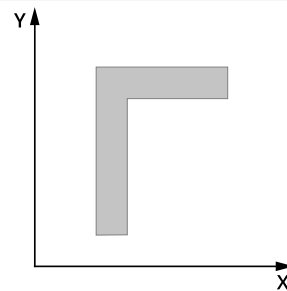

## Parameters

Parameter	Description
Decision	See <i>Decisions</i> (page 100).
Region	See <i>Regions</i> (page 101).
Output	See <i>Output Filters</i> (page 102).

## Ellipse

The Ellipse tool provides measurements for the major and minor axis lengths of an ellipse fitted to the part's shape in the XY plane, and also for the ratio of the major and minor axis lengths and for the orientation angle of the ellipse. The measurement value can be compared with minimum and maximum constraints to yield a decision. See *Adding and Removing Measurements* (page 95) for instructions on adding measurements.

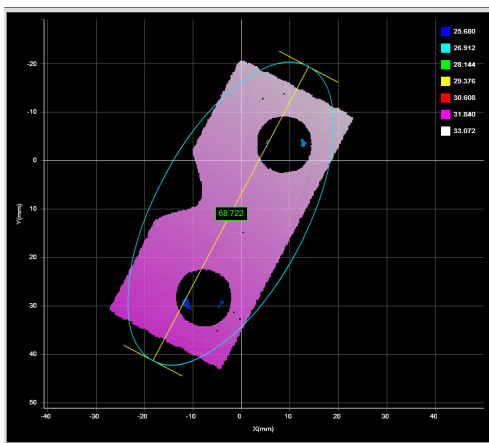

2D View

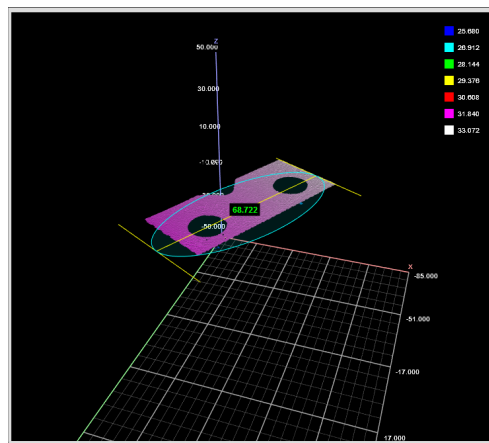

3D View

🔧 Ellipse Major #5 68.722

Link: Disabled ID: 5

---

**Parameters**

Region (R): Reset

---

**Output**

---

**Decision**

Min:  mm      Max:  mm

Remove

Measurement Panel

## Measurements

### Measurement

### Illustration

#### Ellipse Major

Determines the major axis length of an ellipse fitted to the part's area in the XY plane.

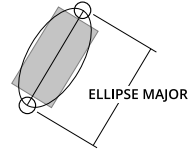

#### Ellipse Minor

Determines the minor axis length of an ellipse fitted to the part's area in the XY plane.

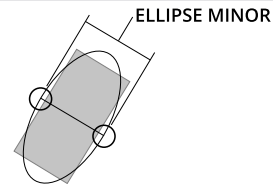

#### Ellipse Ratio

Determines the minor/major axis ratio of an ellipse fitted to the part's area in the XY plane.

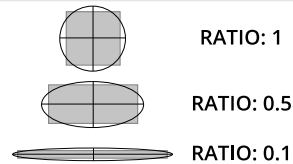

#### Ellipse Angle

Determines the orientation angle of an ellipse fitted to the part's area in the XY plane.

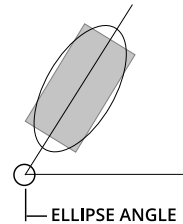

## Parameters

### Parameter

### Description

Decision

See *Decisions* (page 100).

Region

See *Regions* (page 101).

Output

See *Output Filters* (page 102).

## Height

The Height tool determines the height (thickness) of a part. The measurement value can be compared with minimum and maximum constraints to yield a decision. See *Adding and Removing Measurements* (page 95) for instructions on adding measurements.

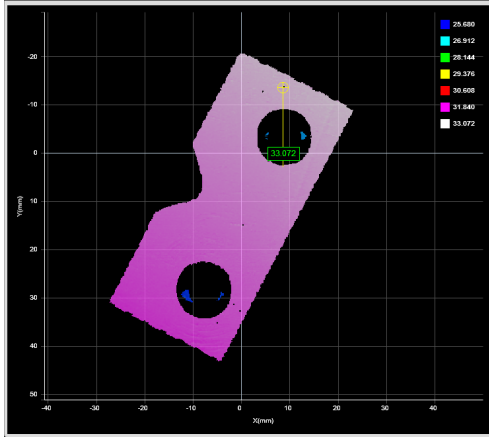

2D View

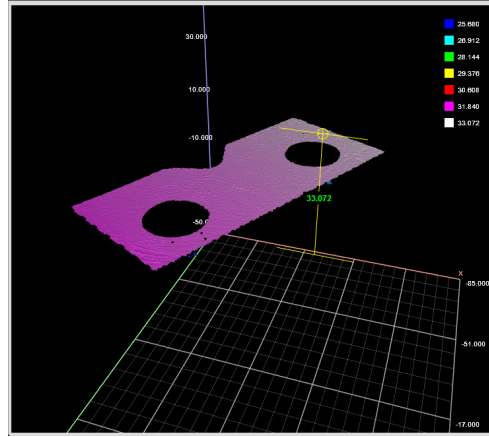

3D View

Height #6
33.072

Link: Disabled
ID: 6

---

**Parameters**

Type: Max

Region (R): Reset

---

**Output**

---

**Decision**

Min:  mm      Max:  mm

Remove

Measurement Panel

## Measurements

### Measurement

#### Height

Measures maximum height, minimum height, average height, median height, or the height at the 2D centroid in the XY plane, or the 3D centroid in XYZ space.

### Illustration

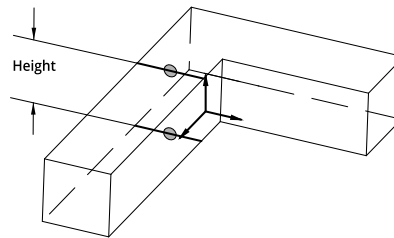

## Bounding Box

The Bounding Box tool provides measurements related to the smallest rectangle box that encapsulates the part (X position, Y position, width, length, and angle).

The measurement value can be compared with minimum and maximum constraints to yield a decision. See *Adding and Removing Measurements* (page 95) for instructions on adding measurements.

A bounding box can be vertical or rotated. A vertical bounding box provides the absolute position from which the Whole Part's Centroids tools are referenced.

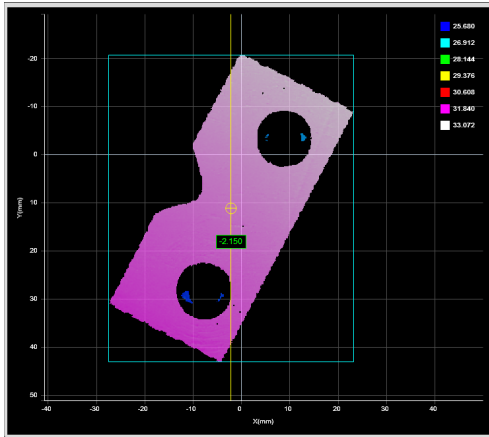

2D View

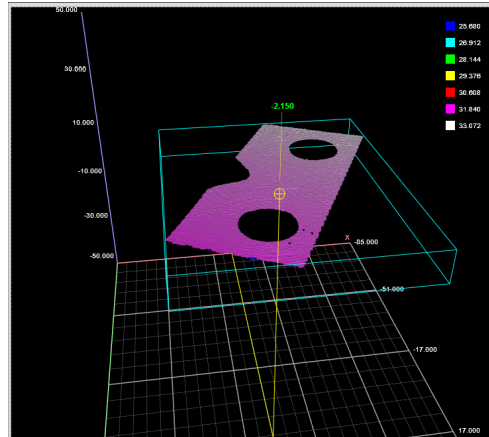

3D View

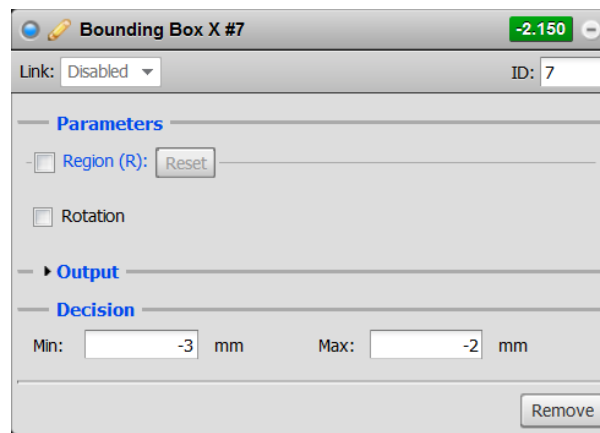

Measurement Panel

*Measurements*

**Measurement**

**Illustration**

**Bounding Box X**

Determines the X position of the center of the smallest rectangle box that encapsulates the part.

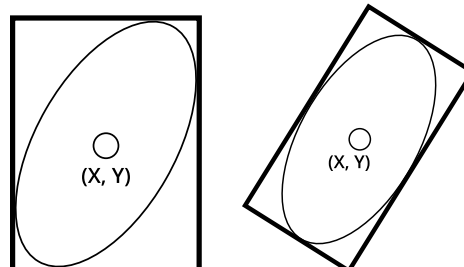

**Bounding Box Y**

Determines the Y position of the center of the smallest rectangle box that encapsulates the part.

---

**Measurement****Illustration****Bounding Box Width**

Determines the width of the smallest rectangle box that encapsulates the part. The width reports the dimension of the box in the direction of the minor axis. When rotation is enabled, the bounding box is not constrained to be aligned with the X-Y coordinate system.

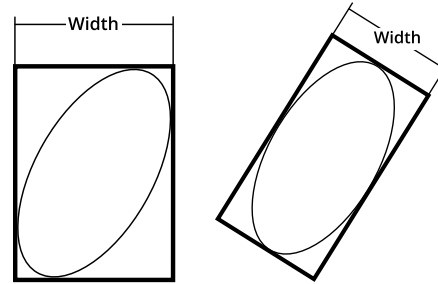
**Bounding Box Length**

Determines the height (thickness) of the smallest rectangle box that encapsulates the part. The length reports the dimension of the box in the direction of the major axis. When rotation is enabled, the bounding box is not constrained to be aligned with the X-Y coordinate system.

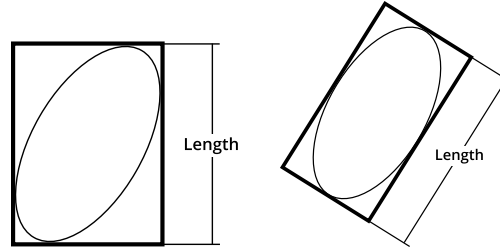
**Bounding Box Angle**

Determines the rotation around the Z axis and the angle of the bounding box relative to the X axis. In order to allow measurement linking of the Bounding Box Angle measurement with the other Bounding Box measurements, the **Rotation** setting is included in this measurement. However, this setting should always be checked. See *Measurement Tool Linking* (page 99) for more information on linking measurements.

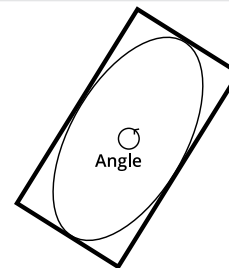

---

*Parameters***Parameter****Description**

Rotation

A bounding box can be vertical or rotated. A vertical bounding box provides the absolute position from which the Whole Part's Centroid tools are referenced (see page 148). Check the Rotation check box to select rotated bounding box.

Decision

See *Decisions* (page 100).

Region

See *Regions* (page 101).

Output

See *Output Filters* (page 102).

## Hole

The Hole tool locates a circular opening within a region of interest on the surface and returns its position and radius.

The hole can be on a surface at an angle to the sensor.

The tool uses a complex feature-locating algorithm to find a hole and then return measurements. See "Hole Algorithm" in the *Gocator Measurement Tool Technical Manual* for a detailed explanation of the algorithm. The behavior of the algorithm can be adjusted by changing the parameters in the measurement panel.

The measurement value can be compared with minimum and maximum constraints to yield a decision. See *Adding and Removing Measurements* (page 95) for instructions on adding measurements.

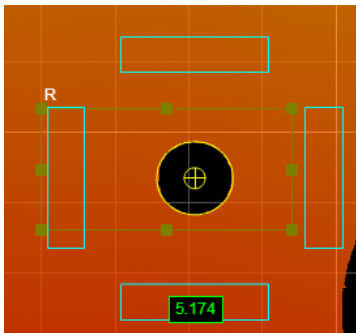
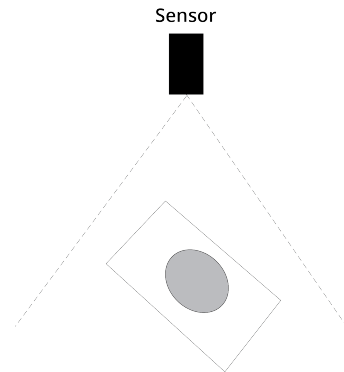

2D View

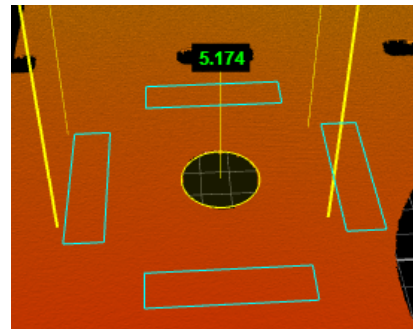

3D View

**Hole Radius #0** 5.174

Link: Disabled ID: 0

**Decision:**  
 Min:  mm      Max:  mm

**Options:**  
 Nominal Radius:  mm  
 Radius Tolerance:  mm  
 Partial Detection

**Region (R):**   
 X:  mm      Width:  mm  
 Y:  mm      Length:  mm  
 Z:  mm      Height:  mm

**Reference Regions:** AutoSet   
 Tilt Correction: AutoSet

Output:

Measurement Panel

Measurements

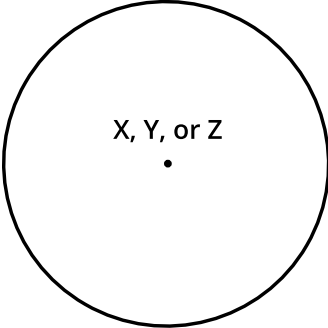
Measurement	Illustration
<p><b>Hole X</b> Determines the X position of the hole center.</p>	
<p><b>Hole Y</b> Determines the Y position of the hole center.</p>	
<p><b>Hole Z</b> Determines the Z position of the hole center.</p>	
<p><b>Hole Radius</b> Determines the radius of the hole.</p>	

Parameters

Parameter	Description
Nominal Radius	Expected radius of the hole.

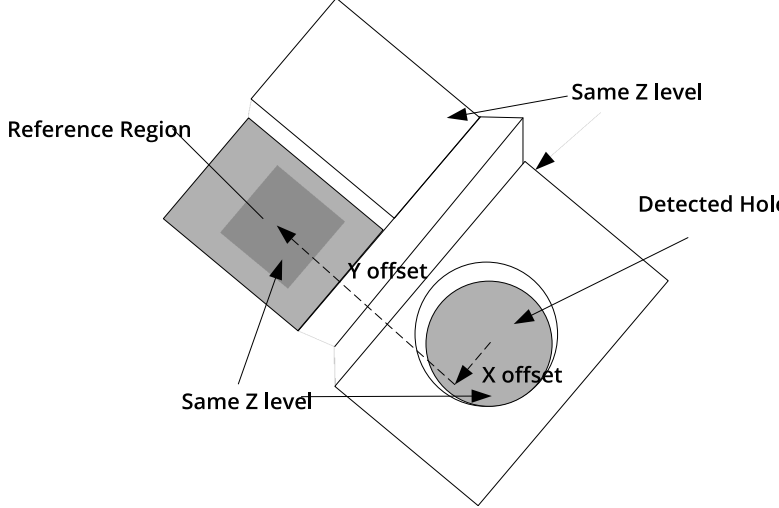
Parameter	Description
Radius Tolerance	The maximum variation from the nominal radius (+/- from the nominal radius).
Reference Regions	<p>The algorithm uses the Reference Regions option to calculate the Z position of the hole. It is typically used in cases where the surface around the hole is not flat.</p>  <p>When this option is set to Autoset, the algorithm automatically determines the reference region. When the option is not set to Autoset, the user manually specifies the reference region. The location of the reference region is relative to the detected center of the hole and positioned on the nominal surface plane. When the Reference Regions option is disabled, the tool measures the hole's Z position using all the data in the measurement region, except for a bounding rectangular region around the hole.</p>
Tilt Correction	<p>Tilt of the target with respect to the alignment plane.</p> <p>When this option is set to Autoset, the tool automatically detects the tilt. Otherwise, the user must enter the angles manually. Autoset requires the measurement region to cover more areas on the surface plane than other planes.</p> <p>The results from the Plane X and Y tool can be used for angles X and Y parameters.</p>
Partial Detection	<p>Enable if only part of the hole is within the measurement region. If disabled, the hole must be completely in the region of interest for results to be valid.</p>

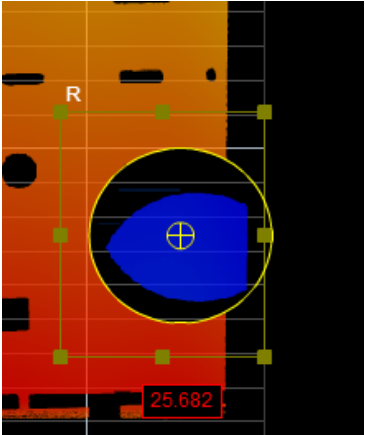
Parameter	Description
	
Decision	See <i>Decisions</i> (page 100).
Region	See <i>Regions</i> (page 101).
Output	See <i>Output Filters</i> (page 102).

### Measurement Region

The center of the hole must be inside the measurement region, even if the Partial Detection option is enabled.

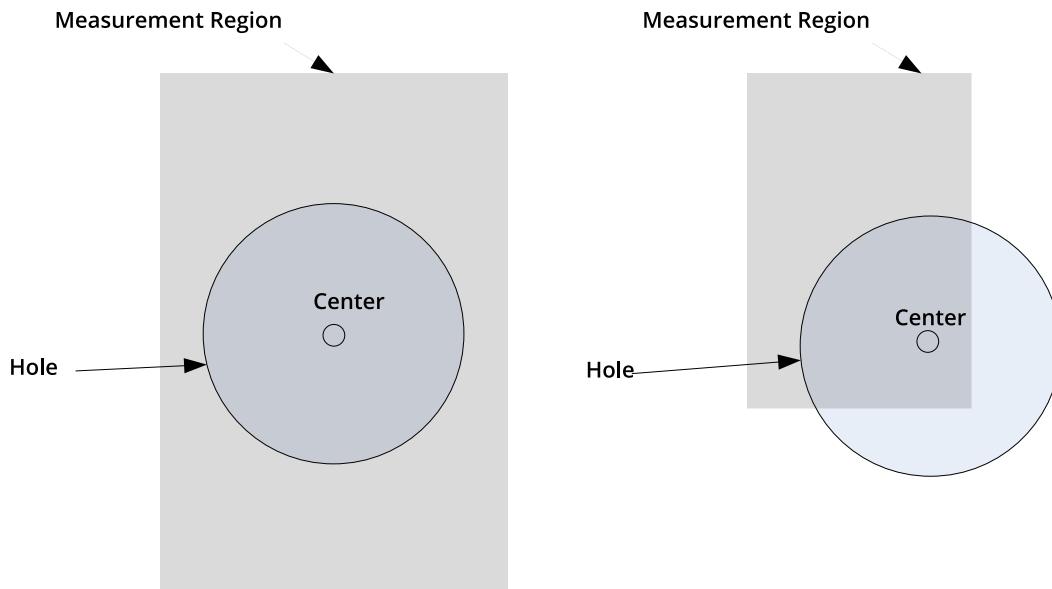

## Stud

The Stud tool measures the location and radius of a stud.

The tool uses a complex feature-locating algorithm to find a stud and then return measurements. See "Stud Algorithm" in the *Gocator Measurement Tool Technical Manual* for a detailed explanation of the algorithm. The behavior of the algorithm can be adjusted by changing the parameters in the measurement panel.

The measurement value can be compared with minimum and maximum constraints to yield a decision. See *Adding and Removing Measurements* (page 95) for instructions on adding measurements.

The location of the stud is defined at either the stud tip or the stud base. The tip is the intersection of the stud axis and the top of the stud; the base is the intersection of the stud axis and the surrounding plane.

The stud shape is defined by the tip height and base height. The base and tip heights specify where the shaft with the nominal radius begins and ends.

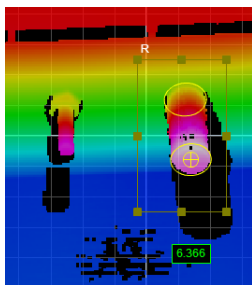
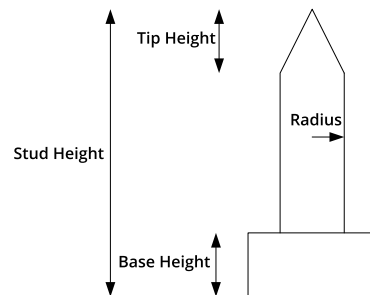
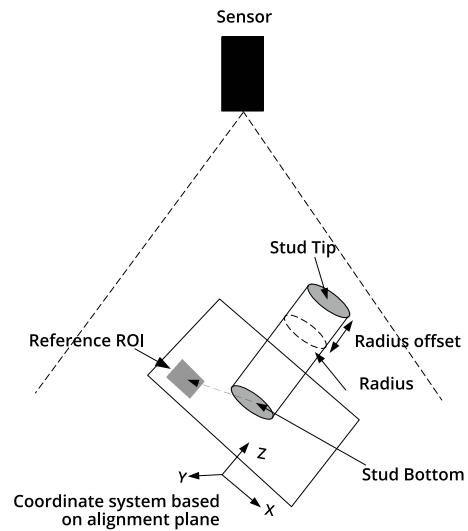

2D View

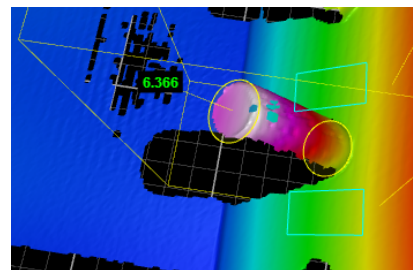

3D View

Stud Radius #8
Invalid

Link: Disabled      ID: 8

---

**Parameters**

Stud Radius:  mm

Stud Height:  mm

Base Height:  mm

Tip Height:  mm

Region (R):

X: <input type="text" value="-25"/> mm	Width: <input type="text" value="50"/> mm
Y: <input type="text" value="-25"/> mm	Length: <input type="text" value="50"/> mm
Z: <input type="text" value="-50"/> mm	Height: <input type="text" value="100"/> mm

Radius Offset:  mm

---

**Advanced**

Reference Regions: AutoSet

Tilt Correction: AutoSet

---

**Output**

---

**Decision**

Min:  mm      Max:  mm

*Measurement Panel*

*Measurements*

**Measurement**

**Illustration**

**Stud Tip X**

Determines the X position of the stud tip.

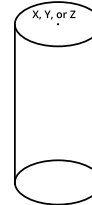

**Stud Tip Y**

Determines the Y position of the stud tip.

**Stud Tip Z**

Determines the Z position of the stud tip.

**Stud Base X**

Determines the X position of the stud base.

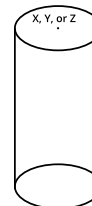

**Stud Base Y**

Determines the Y position of the stud base.

**Stud Base Z**

Determines the Z position of the stud base.

**Stud Radius**

Determines the radius of the stud.

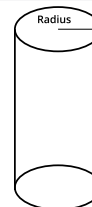

## Parameters

Parameter	Description
Nominal Stud Radius	Expected radius of the stud.
Nominal Stud Length	Expected length of the stud.
Base Height	The height above the base surface that will be ignored when the (truncated) cone is fit to the stud data.
Tip Height	The height from the top of the surface that will be ignored when the (truncated) cone is fit to the stud data.
Radius Offset	The distance from the tip of the stud from which the radius is measured.
Reference Regions	The algorithm uses reference regions to calculate the base plane of the stud. Reference regions are relative to the base of the stud.
Tilt Correction	Tilt of the target with respect to the alignment plane. Set to Auto-Set to have the tool automatically detect the tilt, or enter the angles manually. Auto-Set requires the measurement region to cover more areas on the surface plane than other planes. The results from the Plane X and Y tool can be used for angles X and Y parameters.
Decision	See <i>Decisions</i> (page 100).
Region	See <i>Regions</i> (page 101).
Output	See <i>Output Filters</i> (page 102).

## Measurement Region

The tip and the side of the stud must be within the measurement region.

## Opening

The Opening tool locates rounded, rectangular, and rounded corner openings. The opening can be on a surface at an angle to the sensor. The tool uses a complex feature-locating algorithm to find a hold and then return measurements. See "Opening Algorithm" in the *Gocator Measurement Tool Technical Manual* for a detailed explanation of the algorithm. The behavior of the algorithm can be adjusted by changing the parameters in the measurement panel.

The measurement value can be compared with minimum and maximum constraints to yield a decision. See *Adding and Removing*

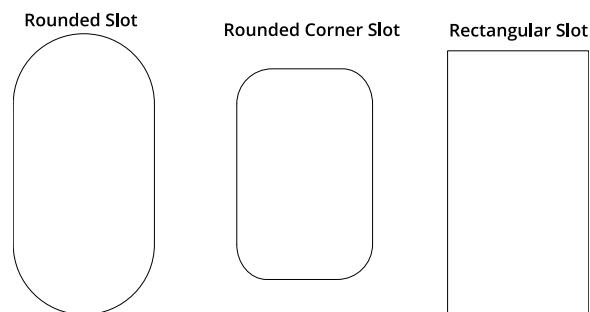

*Measurements* (page 95) for instructions on adding measurements.

You can select the measurement region in which the opening is expected to appear.

The algorithm can separate out background information that appears inside the opening. It can also detect a slot that only partially appears in the data.

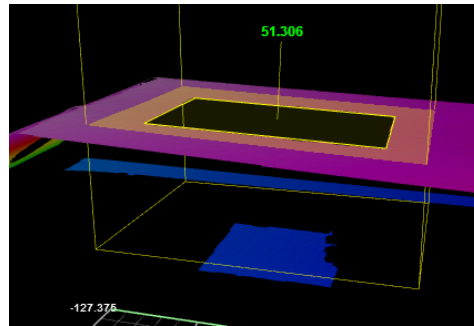

The shape of the opening is defined by its type and its nominal width, length, and radius.

The orientation defines the rotation around the normal of the alignment plane.

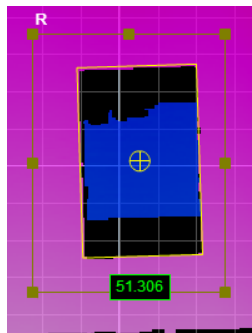
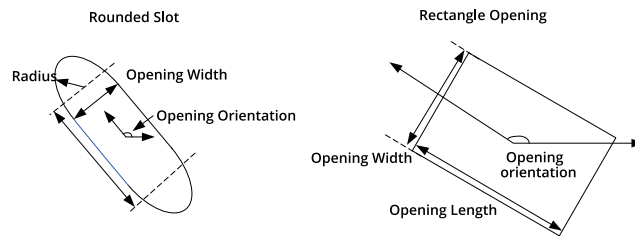

2D View

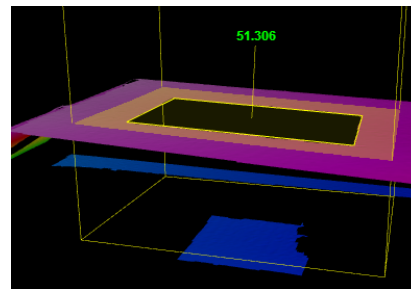

3D View

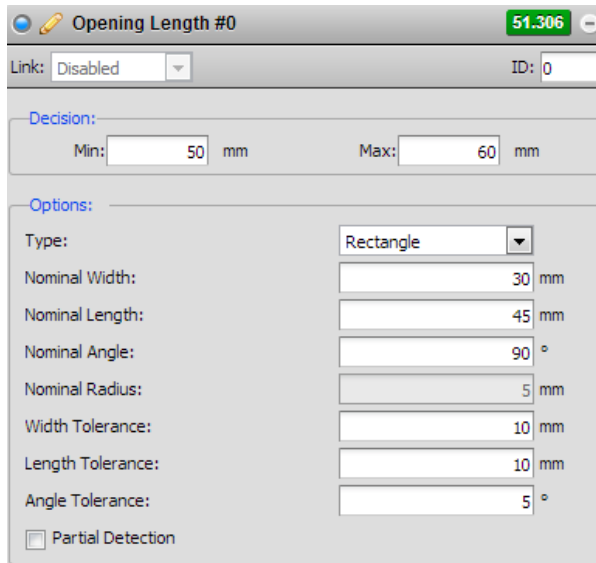

Measurement Panel

Measurements

**Measurement**

**Illustration**

**Opening X**

Determines the X position of the opening's center.

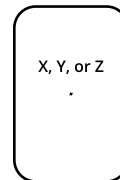

**Opening Y**

Determines the Y position of the opening's center.

**Opening Z**

Determines the Z position of the opening's center.

**Opening Width**

Determines the width of the opening.

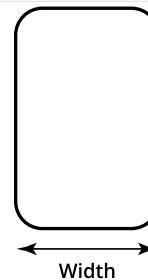

**Opening Length**

Determines the length of the opening.

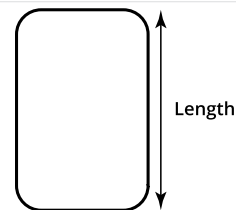

**Opening Angle**

Determines the angle (rotation) around the normal of the alignment plane.

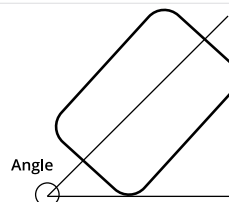

*Parameters*

Parameter	Description
Type	Rounded Slot, Rectangle.
Nominal Width	Nominal width of the opening.
Nominal length	Nominal length of the opening.
Nominal Angle	Nominal angle of the opening. The default orientation is the length of the opening along the X axis.

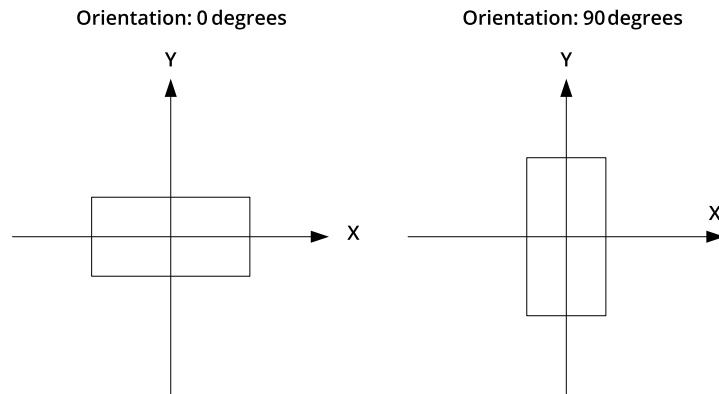

The diagram above illustrates the case where the surface is not tilted. When the surface is tilted, the orientation is defined with respect to the normal of the surface, not with respect to the X-Y plane

**Nominal Radius** Nominal radius of the opening ends. If the opening type is set to rectangular, the radius setting is disabled. The opening has an oval shape if the radius is equal to  $\frac{1}{2}$  of the width. The opening is a rounded rectangle when the radius is less than  $\frac{1}{2}$  of the width.

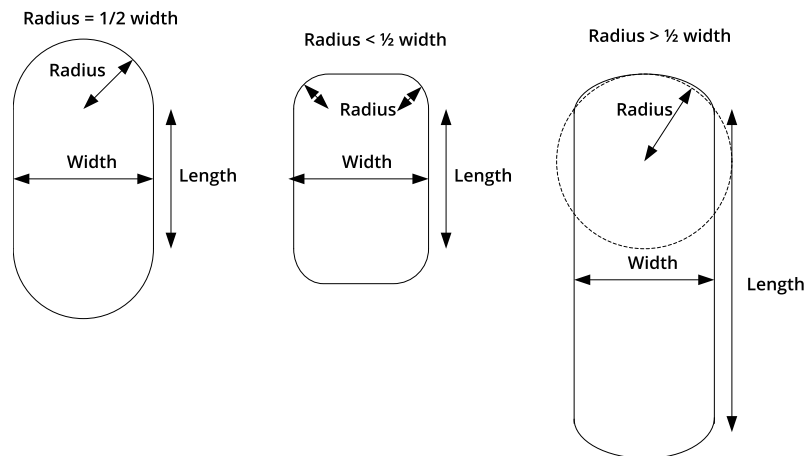

Width Tolerance	The maximum variation from the nominal width (+/- from the nominal value).
Length Tolerance	The maximum variation from the nominal length (+/- from the nominal value).
Orientation Tolerance	The maximum variation from the nominal orientation (+/- from the nominal value).
Reference Regions	The algorithm uses reference regions to calculate the Z position of the hole.

**Parameter**

**Description**

Reference regions are relative to the center location of the feature. This option is typically used in cases where the surface around the opening is not flat.

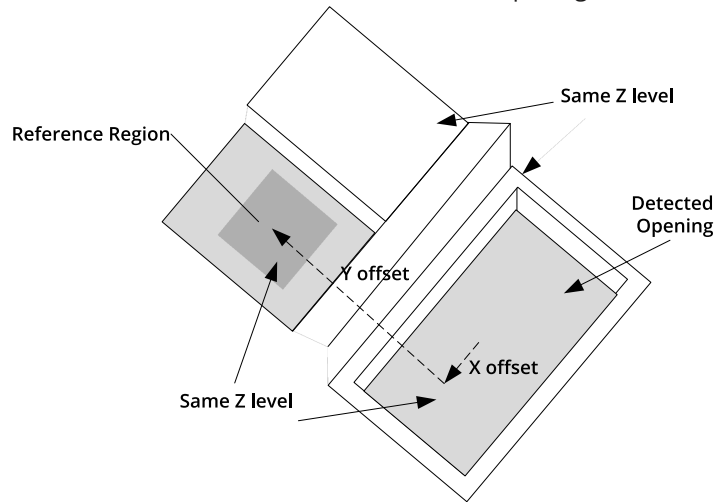

When the Reference Regions setting is disabled, the tool measures the hole's Z position using the all data in the measurement region, except for a bounding rectangular region around the opening.

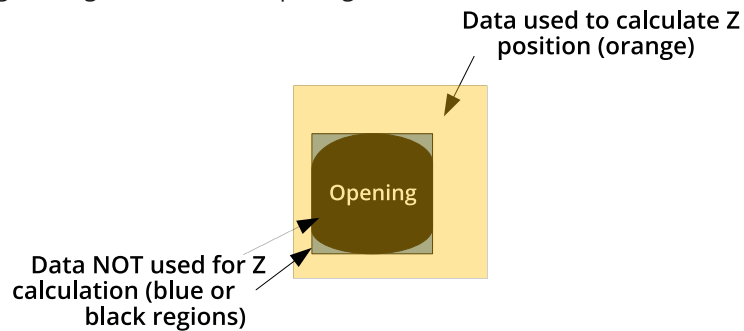

With one or more reference region, the algorithm calculates the Z positions as the average values of the data within the regions.

When the user places the reference region manually, all of the data is used, whether the data is inside or outside the opening. The user should place the reference region carefully.

Tilt Correction

Tilt of the target with respect to the alignment plane. Set to Auto-Set to have the tool automatically detect the target's tilt, or enter the angles manually. Auto-Set requires the measurement region to cover more areas on the surface plane than other planes.

The results from the Plane X and Y tool can be used for angles X and Y parameters.

Decision

See *Decisions* (page 100).

Region

See *Regions* (page 101).

Output

See *Output Filters* (page 102).

## Measurement Region

The center and the two sides and ends of the opening must be within the measurement region, even if Partial Detection is enabled.

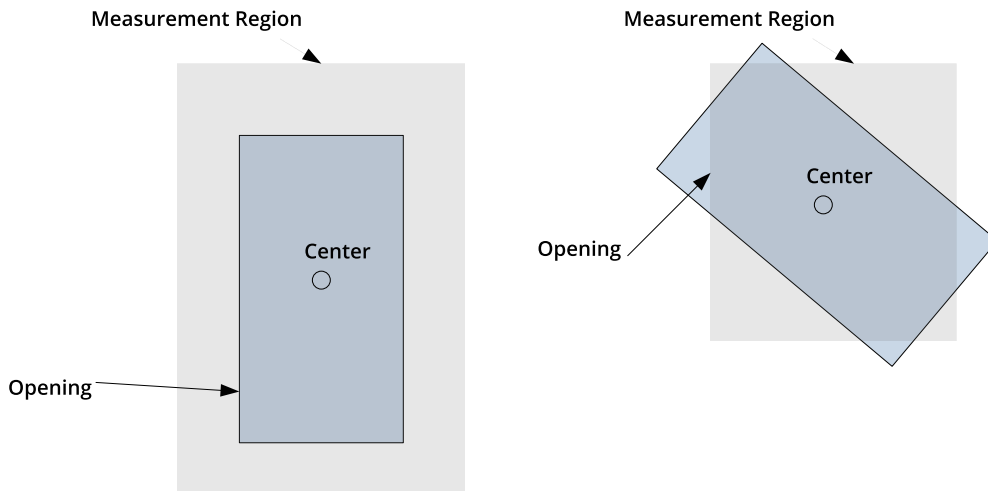

## Plane

The Plane tool provides measurements that report angle X, angle Y, and offset Z of the surface with respect to the alignment target. The measurement value can be compared with minimum and maximum constraints to yield a decision. See *Adding and Removing Measurements* (page 95) for instructions on adding measurements.

The Z offset reported is the Z position at zero position on the X axis and the Y axis.

The results of the Plane Angle X and Plane Angle Y measurements can be used to customize the tilt angle in the Hole, Opening, and Stud tools.

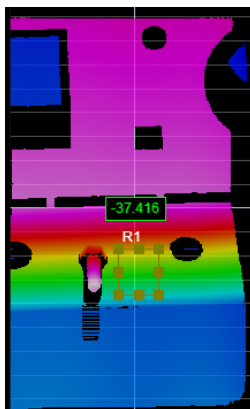

2D View

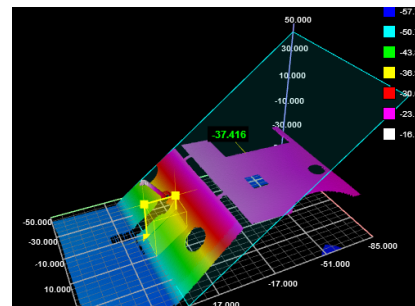

3D View

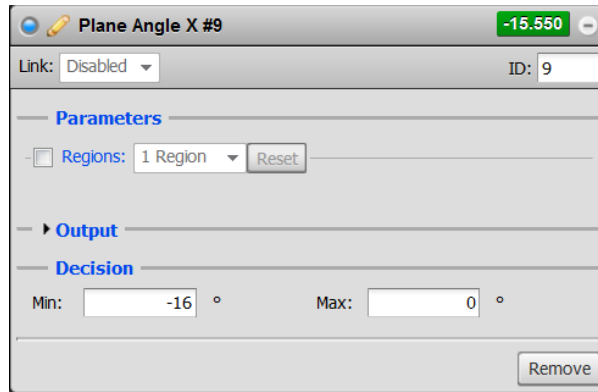

Measurement Panel

## Measurements

### Measurement

### Illustration

#### Plane Angle X

Determines the X angle of the surface with respect to the alignment target.

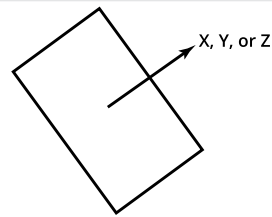

#### Plane Angle Y

Determines the Y angle of the surface with respect to the alignment target.

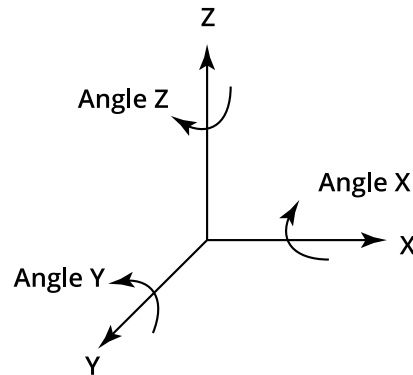

#### Plane Offset Z

Determines the z offset of the surface with respect to the alignment target.

## Parameters

### Parameter

### Description

Decision

See *Decisions* (page 100).

Region

See *Regions* (page 101).

Output

See *Output Filters* (page 102).

## Position

The Position tool reports the X, Y, or Z position of a part. The feature type must be specified and is one of the following: Centroid 2D, Centroid 3D, Min X, Max X, Min Y, Max Y, Min Z, or Max Z. The measurement value can be compared with minimum and maximum constraints to yield a decision. See *Adding and Removing Measurements* (page 95) for instructions on adding measurements.

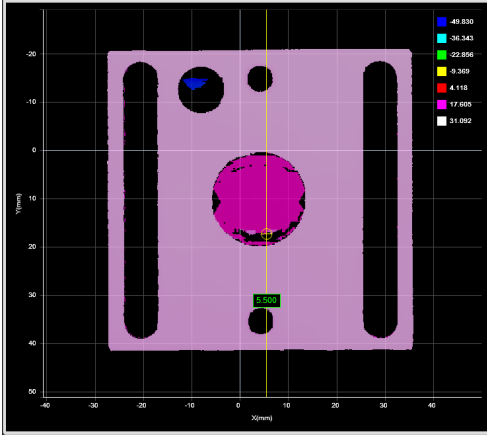

2D View

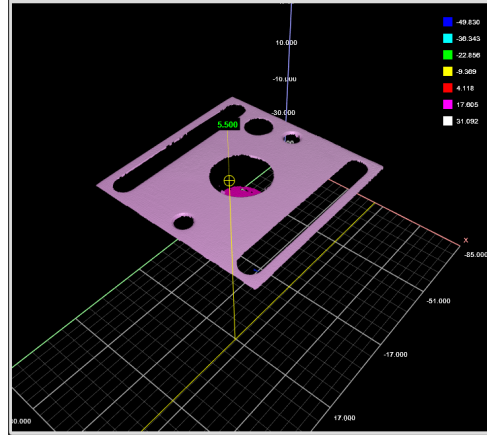

3D View

Position X #10
5.500

Link: Disabled
ID: 10

---

**Parameters**

▼ Feature: Max Z

Region (R): Reset

---

**Output**

---

**Decision**

Min:  mm
Max:  mm

Remove

Measurement Panel

*Measurements*

**Measurement**

**Illustration**

**Position X**

Determines the X position of the selected feature type.

**Position Y**

Determines the Y position of the selected feature type.

**Position Z**

Determines the Z position of the selected feature type.

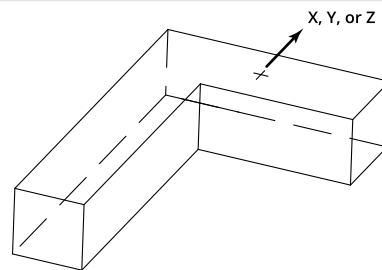

*Parameters*

**Parameter**

**Description**

Feature Type

Choose Centroid 2D, Centroid 3D, Min X, Max X, Min Y, Max Y, Min Z, or Max Z.

Parameter	Description
Decision	See <i>Decisions</i> (page 100).
Region	See <i>Regions</i> (page 101).
Output	See <i>Output Filters</i> (page 102).

**Texture**

The Texture tool provides measurements related to the texture of an object.

The measurement value can be compared with minimum and maximum constraints to yield a decision. See *Adding and Removing Measurements* (page 95) for instructions on adding measurements.

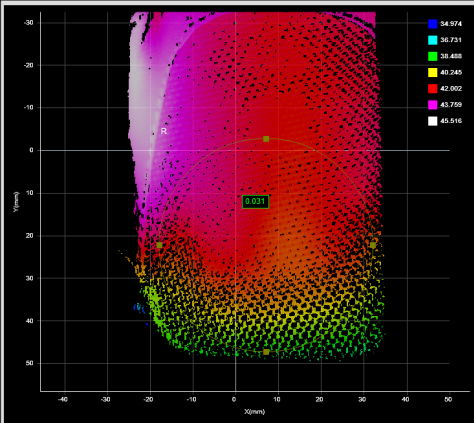

2D View

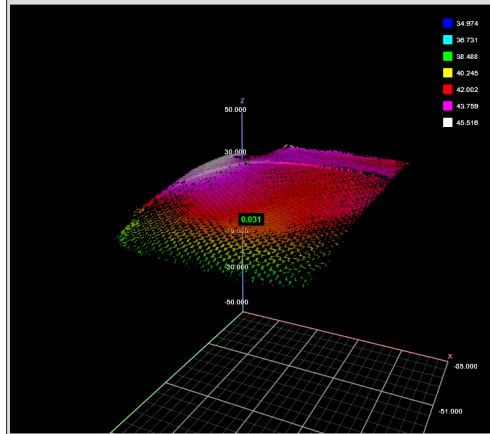

3D View

**Texture Invalid Count #0**

Link:  ID:

---

**Parameters**

Output Type:

▼ **Region (R):**

X:  mm      Radius:  mm

Y:  mm      Height:  mm

Z:  mm

---

► **Output**

---

**Decision**

Min:  mm      Max:  mm

Measurement Panel

## Measurements

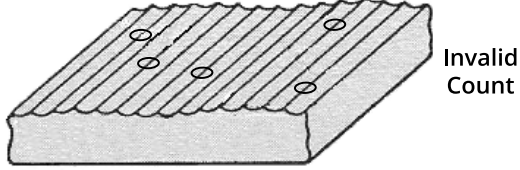
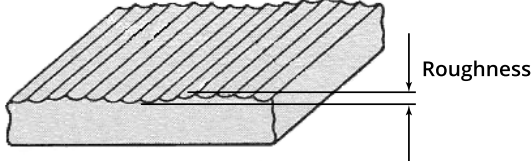
Measurement	Illustration
<b>Texture Invalid Count</b> Produces one of four output types (Invalid/Valid Ratio or Invalid/Valid Area) within a cylindrical region of interest.	
<b>Texture Roughness</b> Determines the average absolute difference in millimeters between all neighboring points within a cylindrical region of interest.	

## Parameters

Parameter	Description
Output Type (Texture Invalid Count measurement only)	One of four types: Invalid Ratio: Percentage of invalid pixels. Valid Ratio: Percentage of valid pixels. Invalid Area: Area of invalid pixels. Valid Area: Area of valid pixels.
Decision	See <i>Decisions</i> (page 100).
Region	The Texture measurements use a Height and a Z setting. Height represents the height of the cylindrical region of interest along the Z axis. Z represents the bottom of the cylindrical region of interest. Example: Z = -10 and Height = 40 is a cylinder with the bottom at -10 mm and the top at 30 mm. See <i>Regions</i> (page 101) for more information.
Output	See <i>Output Filters</i> (page 102).

## Script

A Script measurement can be used to program a custom measurement using a simplified C-based syntax. A script measurement can produce multiple measurement values and decisions for the output.

See *Adding and Removing Measurements* (page 95) for instructions on adding measurements.



```

1 char* name = "Position 2 #0";
2 if (Measurement_NameExists(name))
3 {
4     int id = Measurement_Id(name);
5     Output_SetAt(0, Measurement_Value(id), 1);
6 }
7 else
8 {
9     Output_SetAt(0, 0, 0);
10 }
11

```

See *Script Measurement* (below) for more information on the script syntax.

*To create or edit a Script measurement:*

1. Add a new Script measurement or select an existing Script measurement.
2. Edit the script code.
3. Choose the number of desired script outputs using the + and – buttons.  
For each script output that is added, an index will be added to the **Output** drop-down and a unique ID will be generated.
4. Click the **Save** button to save the script code.  
If there is a mistake in the script syntax, the result will be shown as a "invalid" with a red border in the data viewer when you run the sensor.  
Outputs from multiple measurement tools can be used as inputs to the script. A typical script would take results from other measurement tools using the value and decision function, and output the result using the output function. Stamp information, such as time and encoder stamps, are available in the script, whereas the actual profile data is not. The script engine is not powerful enough to process the profile data itself. Only one script can be created.

## Script Measurement

A Script measurement can be used to program a custom measurement using a simplified C-based syntax. Similar to other measurement tools, a script measurement can produce multiple measurement values and decisions for the output.

The following elements of the C language are supported:

### Supported Elements

Elements	Supported
Control Operators	if, while, do, for, switch and return.
Data Types	char, int, unsigned int, float, double, long long (64-bit integer).
Arithmetic and Logical Operator	Standard C arithmetic operators, except ternary operator (i.e., "condition? trueValue: falseValue"). Explicit casting (e.g., int a = (int) a_float) is not supported.
Function Declarations	Standard C function declarations with argument passed by values. Pointers are not supported.

## Built-in Functions

### Measurement Functions

Function	Description
int Measurement_Exists(int id)	Tests for the existence of a measurement by ID. Parameters: id - Measurement ID Returns: 0 - measurement does not exist 1 - measurement exists
int Measurement_Valid(int id)	Retrieves the valid/invalid state of a measurement by its ID. Parameters: id - Measurement ID Returns: 0 - Measurement is invalid 1 - Measurement is valid
long long Measurement_Value (int id)	Retrieves the value of a measurement by its ID. Parameters: id - Measurement ID Returns: Value of the measurement 0 - if measurement does not exist A measurement value is received as a fixed point integer with a scaling of 1/1000. For example, a 3.654mm value is received as 3654.
int Measurement_Decision (int id)	Retrieves the decision of a measurement by its ID. Parameters: ID - Measurement ID Returns: Decision of the measurement 0 - if measurement decision is false 1 - If measurement decision is true
int Measurement_NameExists(char *name)	Determines if a measurement exist by name. Parameter: name - name of a measurement Return: 0 - measurement does not exist 1 - measurement exists
int Measurement_Id (char *name)	Retrieves the measurement ID by the measurement name. Parameters: name - name of a measurement Returns: -1 - measurement does not exist

Function	Description
	Other – Measurement ID
void Output_Set (long long value, int decision)	Output a value and decision on Output index 0. Only the last output value / decision in a script run is kept and passed to the Gocator output. To output an invalid value, the constant INVALID_VALUE can be used (e.g., Output_SetAt(0, INVALID_VALUE, 0)) Parameters: value - value output by the script decision - decision value output by the script. Can only be 0 or 1
void Output_SetAt(unsigned int index, long long value, int decision)	Sets the output value and decision at the specified output index. To output an invalid value, the constant INVALID_VALUE can be used (e.g., Output_SetAt(0, INVALID_VALUE, 0)) Parameters: index – Script output index value – value output by the script decision – decision value output by the script. Can only be 0 or 1
void Output_SetId(int id, long long value, int decision)	Sets the output value and decision at the specified script output ID. To output an invalid value, the constant INVALID_VALUE can be used (e.g., Output_SetId(0, INVALID_VALUE, 0)) Parameters: id – Script output ID

### Memory Functions

Function	Description
void Memory_Set64s (int id, long long value)	Stores a 64-bit signed integer in persistent memory. Parameters: id - ID of the value value - Value to store
long long Memory_Get64s (int id)	Retrieves a 64-bit signed integer from persistent memory. Parameters: id - ID of the value Returns: value - Value stored in persistent memory
void Memory_Set64u (int id, unsigned long long value)	Stores a 64-bit unsigned integer in the persistent memory Parameters: id - ID of the value value - Value to store
unsigned long long Memory_Get64u (int id)	Retrieves a 64-bit unsigned integer from persistent memory. Parameters: id - ID of the value Returns: value - Value stored in persistent memory
void Memory_Set64f (int id, double value)	Stores a 64-bit double into persistent memory.

Function	Description
	Parameters: id - ID of the value value - Value to store
double Memory_Get64f (int id)	Retrieves a 64-bit double from persistent memory. All persistent memory values are set to 0 when the sensor starts. Parameters: id - ID of the value Returns: value - Value stored in persistent memory
int Memory_Exists (int id)	Tests for the existence of a value by ID. Parameters: id - Value ID Returns: 0 - value does not exist 1 - value exists
void Memory_Clear (int id)	Erases a value associated with a ID. Parameters: id - Value ID
void Memory_ClearAll()	Erases all value from persistent memory

### *Stamp Functions*

Function	Description
long long Stamp_Frame()	Retrieves the frame index of the current frame.
long long Stamp_Time()	Retrieves the time stamp of the current frame.
long long Stamp_Encoder()	Retrieves the encoder position of the current frame.
long long Stamp_EncoderZ()	Retrieves the encoder index position of the current frame.
unsigned int Stamp_Inputs()	Retrieves the digital input state of the current frame.

### *Math Functions*

Function	Description
float sqrt(float x)	Calculates square root of x
float sin(float x)	Calculates sin(x) (x in radians)
float cos(float x)	Calculates cos(x) (x in radians)
float tan(float x)	Calculates tan(x) (x in radians)
float asin(float x)	Calculates asin(x) (x in radians)
float acos(float x)	Calculates acos(x) (x in radians)
float atan(float x)	Calculates atan(x) (x in radians)
float pow (float x, float y)	Calculates the exponential value. x is the base, y is the exponent
float fabs(float x)	Calculates the absolute value of x

### Example: Accumulated Volume

The following example shows how to create a custom measurement that is based on the values from other measurements and persistent values. The example calculates the volume of the target using a series of box area measurement values.

```
/* Calculate the volume of an object by accumulating the boxArea measurements*/
/* Encoder Resolution is 0.5mm. */
/* BoxArea Measurement ID is set to 1*/

long long encoder_res = 500;
long long boxArea = Measurement_Value(1);
long long Volume = Memory_Get64s(0);

Memory_Set64s(0, Volume);
if (Volume > 1000000)
{
    Output_Set(Volume, 1);
}
else
{
    Output_Set(Volume, 0);
}
```

# Output

The following sections describe the **Output** page.

## Output Page Overview

Output configuration tasks are performed using the Output Page. Gocator sensors can transmit laser profiles and measurement results to various external devices using several output interface options.

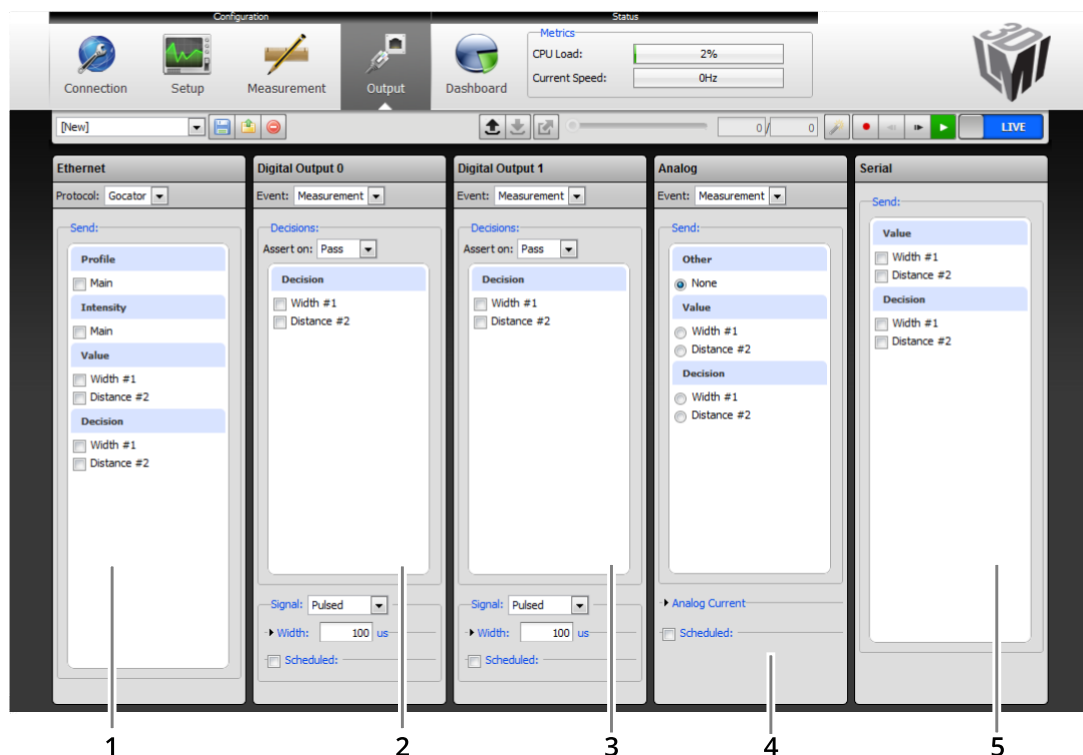

Element	Description
1 Ethernet Panel	Use the <b>Ethernet</b> panel to select the data sources that will transmit data via Ethernet. See <i>Ethernet Output</i> (below).
2 Digital Output 0 Panel	Use the <b>Digital Output 0</b> panel to select the data sources that will be combined to produce a digital output pulse on Output 0. See <i>Digital Outputs</i> (page 161).
3 Digital Output 1 Panel	Use the <b>Digital Output 1</b> panel to select the data sources that will be combined to produce a digital output pulse on Output 1. See <i>Digital Outputs</i> (page 161).
4 Analog Panel	Use the <b>Analog</b> panel to convert a measurement value or decision into an analog output signal. See <i>Analog Output</i> (page 164).
5 Serial Panel	Use the <b>Serial</b> panel to select the measurements that will be transmitted via RS-485 serial output. See <i>Serial Output</i> (page 166).

## Ethernet Output

A sensor uses TCP messages (Gocator Protocol) to exchange commands, video, laser profile, intensity, and measurement results with client computers. The sensor can also exchange commands and

measurement results with a PLC using ASCII, Modbus TCP, or EtherNet/IP protocol. See *Protocols* (page 253) for the specification of these protocols.

**Ethernet**

Protocol: Gocator ▼

Send:

**Profile**

Main

**Intensity**

Main

**Value**

Width #1

Distance #2

**Decision**

Width #1

Distance #2

To exchange results using Gocator Protocol messages:

1. Navigate to the **Ethernet** panel.
2. Select **Gocator** in **Protocol Option**.
3. Select the video, profile, intensity, decision value, or decision items to send.  
To select an item for transmission, place a check in the corresponding check box.



Measurements shown here correspond to measurements that have been programmed using the Measurements page.

All of the tasks that can be accomplished via the Gocator's web interface (configuration, calibration, receiving data, health information, and software triggering, etc.) can be accomplished programmatically by sending and receiving Gocator Protocol control commands.

The screenshot shows the 'Ethernet' configuration panel. At the top, the 'Protocol' is set to 'ASCII'. Below this, the 'Send' section includes 'Operation' set to 'Asynchronous' and 'Data Format' set to 'Standard'. There are two sections, 'Value' and 'Decision', each with a checked checkbox for 'Strip Height #0'. The 'Special Characters' section has 'Delimiter' set to ',', 'Termination' set to '%r%n', and 'Invalid Value' set to 'INVALID'. The 'Ports' section has 'Control', 'Data', and 'Health' all set to '8190'.

To exchange results using ASCII messages:

1. Navigate to the **Ethernet** panel.
2. Select **ASCII** in **Protocol Option**.
3. Select the **Operation Mode**.  
In asynchronous mode, the data results are transmitted when they are available. In polling mode, users send commands on the data channel to request the latest result. See *Asynchronous and Polling Operation* (page 298) for an explanation of the operation modes.
4. Select the **Data Format**.  
Select **Standard** to use the default result format of the ASCII protocol. Select value and decision to send by placing a check in the corresponding check box. See *Standard Result Format* (page 300) for an explanation of the standard result mode.
5. Set the Special Characters.  
Select the delimiter, termination, and invalid value characters. Special characters are used in commands and standard-format data results.
6. Set the TCP Ports.  
Select the TCP ports for the command, data, and health channels. If the port numbers of two channels are the same, the messages for both channels are transmitted on the same port.

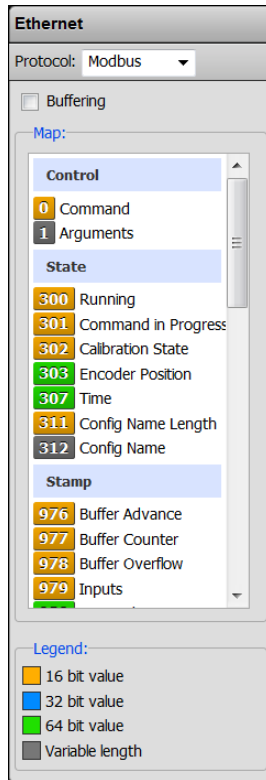

*To receive commands and send results using Modbus TCP messages:*

1. Navigate to the **Ethernet** panel.
2. Select **Buffering** if desired.  
 Buffering is needed, for example, in Whole Part mode if multiple objects are detected within a time frame shorter than the polling rate of the PLC.  
 If buffering is enabled with the Modbus protocol, the PLC must read the Advance register to advance the queue before reading the measurement results.
3. Select **Modbus** in **Protocol Option**.  
 Unlike using the Gocator Protocol, there is no need to select which measurement items to output. The Ethernet panel will list the register addresses that are used for Modbus TCP communication.  
 The Modbus TCP Protocol can be used to operate a sensor. Modbus TCP only supports a subset of the tasks that can be accomplished in the web interface. A sensor can only process Modbus TCP commands when the Modbus is selected in the protocol option.

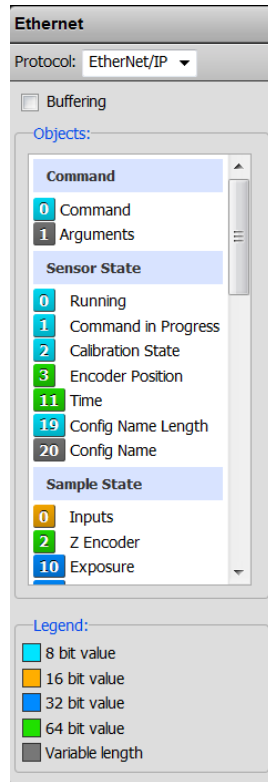

To receive commands and send results using EtherNet/IP messages:

1. Navigate to the **Ethernet** panel.
2. Select **Buffering** if desired.  
Buffering is needed, for example, in Whole Part mode if multiple objects are detected within a time frame shorter than the polling rate of the PLC. If buffering is enabled with the EtherNet/IP protocol, the buffer is automatically advanced when the Sample State Assembly Object (see page 295) is read.
3. Select **EtherNet/IP** in the **Protocol** option.  
Unlike using the Gocator Protocol, there is no need to select which measurement items to output. The **Ethernet** panel will list the register addresses that are used for EtherNet/IP messages communication. The EtherNet/IP Protocol can be used to operate a sensor. EtherNet/IP only supports a subset of the tasks that can be accomplished in the web interface. A sensor can only process EtherNet/IP commands when the EtherNet/IP is selected in the protocol option.

## Digital Outputs

Gocator sensors can convert measurement decisions or software commands to digital output pulses, which can then be used to output to a PLC or to control external devices, such as indicator lights or air ejectors.

A digital output can act as a measurement valid signal to allow external devices to synchronize to the timing at which measurement results are output. In this mode, the sensor outputs a digital pulse when a measurement result is ready.

A digital output can also act as a strobe signal to allow external devices to synchronize to the timing at which the sensor exposes. In this mode, the sensor outputs a digital pulse when the sensor exposes.

Each sensor supports two digital output channels. For Gocator 2000 sensors, see *Digital Outputs* (page 359) for information on wiring digital outputs to external devices. For Gocator 2300 sensors, see *Gocator Power/LAN Connector* (page 356).

The screenshot shows the 'Digital Output 1' configuration panel. At the top, the title is 'Digital Output 1'. Below it, the 'Event' is set to 'Measurement'. Under the 'Decisions' section, 'Assert on' is set to 'Pass'. A 'Decision' box contains two checkboxes: 'Width #1' and 'Distance #2', both of which are currently unchecked. Below the decision box, the 'Signal' is set to 'Pulsed'. The 'Width' is set to '100 us' with a slider control below it. The 'Scheduled' checkbox is checked, and the 'Delay' is set to '0 mm'.

To output measurement decisions:

1. Navigate to the **Digital Output 0** or **Digital Output 1** panel.
2. Set **Event** to **Measurement**.
3. Select **Assert Mode** and decision sources that should be combined to determine the output.  
If multiple decision sources are selected and assert mode is set to pass, the output is activated when all selected measurement decisions pass. Conversely, if assert mode is set to false, the output is activated when any one of the selected measurement decisions is false.
4. Specify a **Signal** type.  
The signal type specifies whether the digital output is a continuous signal or a pulsed signal. If the signal is continuous its state is maintained until the next transition occurs. If the signal is pulsed, the user specifies the pulse width and how it is scheduled.
5. Specify a **Pulse Width**.  
The pulse width is the duration of the digital output pulse, in microseconds.

6. Specify whether the output is **Immediate** or **Scheduled**.

A pulsed digital output can be immediate or scheduled. Check the **Scheduled** option if the output needs to be scheduled.

A scheduled output becomes active after a specified delay from the start of Gocator exposure. A scheduled output can be used to track the decisions for multiple objects as these objects travel from the sensor to the eject gates. The **Delay** setting specifies the distance from the sensor to the eject gates.

An immediate output becomes active as soon as measurement results are available. The output activates after the sensor finishes processing the data. As a result, the time between the start of sensor exposure and output activates can vary and is dependent on the processing latency. The latency is reported in the dashboard and in the health messages.

7. Specify a Delay.

The delay specifies the time or spatial location between the start of sensor exposure and when the output becomes active. The delay should be larger than the time needed to process the data inside the sensor. It should be set to a value that is larger than the processing latency reported in the dashboard or in the health messages.

The unit of the delay is configured in the trigger panel. See *Trigger Panel* (page 64) for details.

*To output a measurement valid signal:*

1. Navigate to the **Digital Output 0** or **Digital Output 1** panel.

2. Set **Event** to **Measurement**.

3. Set **Assert On** to **Always**.

4. Select decision sources.

The output activates when the selected decisions produce results. The output activate only once for each frame even if multiple decision sources are selected.

5. Specify a **Pulse Width**.

The pulse width determines the duration of the digital output pulse, in microseconds.

*To respond to software scheduled commands:*

1. Navigate to the **Digital Output 0** or **Digital Output 1** panel.

2. Set **Event** to **Software**.

3. Specify a **Signal** type.

The signal type specifies whether the digital output is a continuous signal or a pulsed signal. If the signal is continuous, its state is maintained until the next transition occurs. If the signal is pulsed, user specifies the pulse width and the delay.

4. Specify a **Pulse Width**.

The pulse width determines the duration of the digital output pulse, in microseconds.

5. Specify if the output is **Immediate** or **Scheduled**.

A pulsed signal can become active immediately or scheduled. Continuous signal always becomes active

immediately.

Immediate output becomes active as soon as a scheduled digital output (see page 271) is received. Scheduled output becomes active at a specific target time or position, given by the Scheduled Digital Output command. The **Delay** setting in the panel is ignored. Commands that schedule event in the past will be ignored. An encoder value is in future if the value will be reached by moving in the forward direction (the direction that travel calibration was performed in).

*To output an exposure signal:*

1. Navigate to the **Digital Output 0** or **Digital Output 1** panel.
2. Set **Event** to **Exposure**.
3. Specify a **Pulse Width**.

The pulse width determines the duration of the digital output pulse, in microseconds.

## Analog Output

Gocator sensors can convert a measurement result or software request to an analog output. Each sensor supports one analog output channel.

For the Gocator 2000 series, see *Analog Output* (page 354) for information on wiring analog output to an external device. For the Gocator 2300 series, see *Analog Output* (page 361).

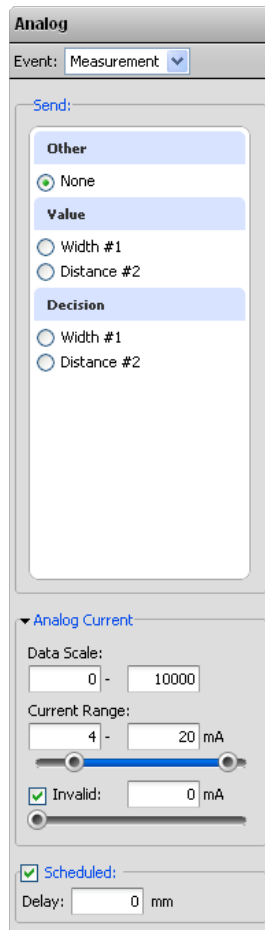

**Analog**

Event: Measurement

Send:

**Other**

None

**Value**

Width #1

Distance #2

**Decision**

Width #1

Distance #2

**Analog Current:**

Data Scale: 0 - 10000

Current Range: 4 - 20 mA

Invalid: 0 mA

Scheduled:

Delay: 0 mm

To output measurement value or decision:

1. Navigate to the **Analog** panel.
2. Set **Event** to **Measurement**.
3. Select the value or decision source that should be used for output.  
Only one value or decision can be used for analog output. Measurements shown here correspond to measurements that have been programmed using the **Measurements** page.
4. Specify **Data Scale** values.  
The values specified here determine how measurement values are scaled to the minimum and maximum current output. The **Data Scale** values are specified in (um) for dimensional measurement, (0.001 mm<sup>2</sup>) for area, (mm<sup>3</sup>) for volume, and (0.001 degree) for angle results.  
The values specified here determine the minimum and maximum current values in milliamperes. The invalid current value is used when a measurement value is not valid. If invalid is not checked, the output holds the last value when a measurement value is not valid.
5. Specify **Current Range** and **Invalid** current values.  
The values specified here determine the minimum and maximum current values in milliamperes. If **Invalid** is checked, the current value specified with the slider is used when a measurement value is not valid. If **Invalid** is not checked, the output holds the last value when a measurement value is not valid.

6. Specify if the output is immediate or scheduled.

An analog output can become active immediately or scheduled. Check the **Scheduled** option if the output needs to be scheduled.

A scheduled output becomes active after a specified delay from the start of Gocator exposure. A scheduled output can be used to track the decisions for multiple objects as these objects travel from the sensor to the eject gates. The delay specifies the distance from the sensor to the eject gates.

An Immediate output becomes active as soon as the measurement results are available. The output activates after the Gocator finishes processing the data. As a result, the time between the start of Gocator exposure and output activates depends on the processing latency. The latency is reported in the dashboard and in the health messages.

7. Specify a delay.

The delay specifies the time or spatial location between the start of Gocator exposure and the output becomes active. The delay should be larger than the time needed to process the data inside the Gocator. It should be set to a value that is larger than the processing latency reported in the dashboard and in the health messages.

The unit of the delay is configured in the trigger panel. See *Trigger Panel* (page 64) for details.



The analog output takes about 75  $\mu$ s to reach 90% of the target value for a maximum change, then another  $\sim$ 40  $\mu$ s to settle completely.

*To respond to software scheduled commands:*

1. Navigate to the **Analog** panel.
2. Set **Event** to **Software**.
3. Specify if the output is **Immediate** or **Scheduled**.

An analog output value becomes active immediately or scheduled. Immediate output becomes active as soon as a Scheduled Analog Output command (see page 272) is received.

Software scheduled command can schedule an analog value to output at a specified future time or encoder value, or changes its state immediately. The Delay setting in the panel is ignored. Commands that schedule event in the past will be ignored. An encoder value is in future if the value will be reached by moving in the forward direction (the direction that travel calibration was performed in).

## Serial Output

The Gocator's web interface can be used to select measurement values and decisions to be transmitted via RS-485 serial output. Each sensor has one serial output channel.

See *Serial Communication* (page 298) for serial connection parameters and data formats. For Gocator 2000 sensors, see *Serial Output* (page 354) for information on wiring serial output to an external device. For Gocator 2300 sensors, see *Serial Output* (page 361).

To exchange results using ASCII messages:

1. Navigate to the **Ethernet** panel.
2. Select **ASCII** in the **Protocol** option.
3. Select the **Data Format**.  
 Select **Standard** to use the default result format of the ASCII protocol. Select value and decision to send by placing a check in the corresponding check box. See *Standard Result Format* (page 300) for an explanation of the standard result mode.  
 Select **Custom** to customize the output result. A data format box will appear in which users can type the format string. See *Custom Result Format* (page 300) for the supported format string syntax.
4. Set the **Special Characters**.  
 Select the delimiter, termination and invalid value characters. Special characters are used in commands and standard-format data results.

# Dashboard

The following sections describe the dashboard.

## Dashboard Page Overview

The Dashboard page summarizes logged events, sensor health information, and measurement statistics.

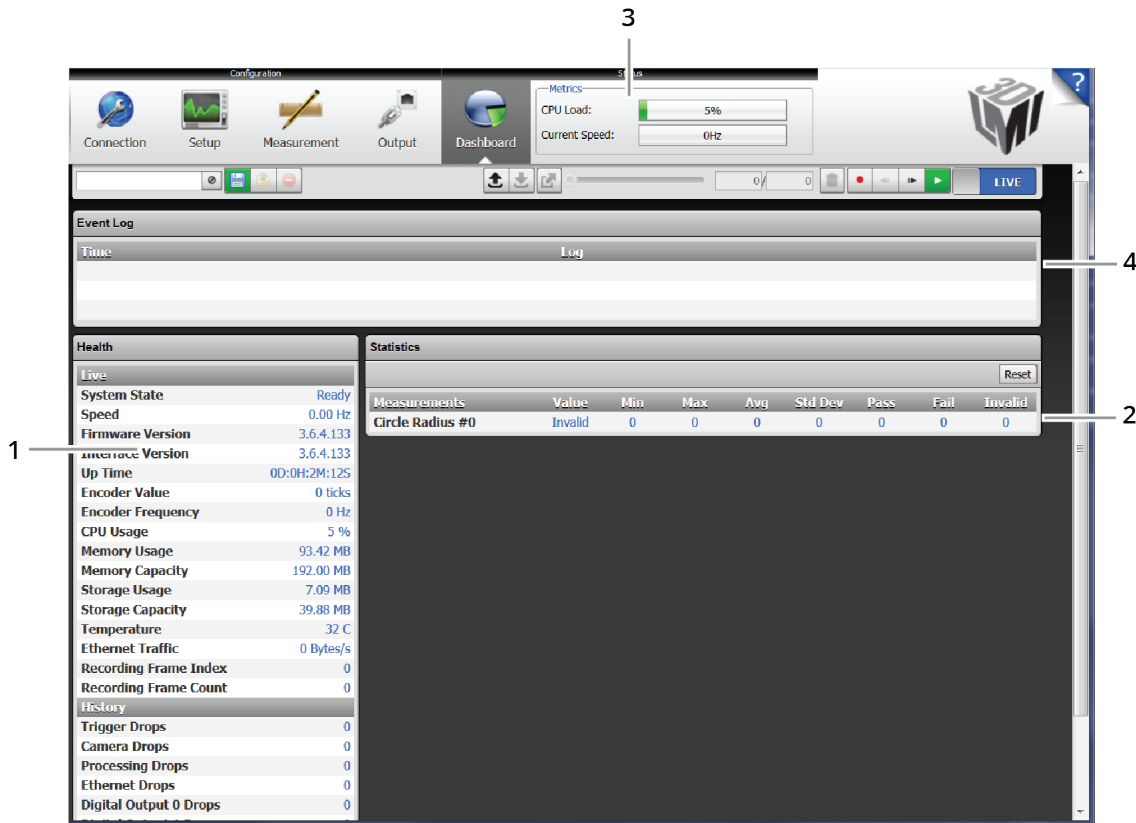

Element	Description
1 State and Health Information	Displays sensor state and health information. See <i>State and Health Information</i> (below).
2 Measurement Statistics	Displays measurement statistics. See <i>Measurement Statistics</i> (next page).
3 Metrics Panel	Summarizes important performance statistics.
4 Event Log	Displays log data from the sensor.

## State and Health Information

The following state and health information is available on the Dashboard:

### Dashboard Health Values

Name	Description
System State	Current system state (Ready or Running).
Speed	Current laser/camera speed (Hz).

Firmware Version	Gocator firmware version.
Interface Version	Gocator interface version.
Up Time	Length of time since the sensor was power-cycled or reset.
Encoder Value	Current encoder value (ticks).
Encoder Frequency	Current encoder frequency (Hz).
Trigger Drops	Count of camera frames dropped due to excessive trigger speed.
CPU Usage	Sensor CPU utilization (%).
Memory Usage	Sensor memory utilization (MB).
Memory Capacity	Sensor memory capacity (MB).
Storage Usage	Sensor flash storage utilization (MB).
Storage Capacity	Sensor flash storage capacity (MB).
Temperature	Sensor internal temperature (C).
Laser Temperature	Sensor laser temperature (C). Only available on sensors equipped with 3B-N lasers
Ethernet Traffic	Network output utilization (Bytes/sec).
Camera Drops	Count of frame drops due to camera errors.
Processing Drops	Count of frame drops due to excessive CPU utilization.
Ethernet Drops	Count of frame drops due to slow Ethernet link.
Digital Output Drops	Count of digital output drops because last output has not been completed.
Analog Output Drops	Count of analog output drops because last output has not been completed.
Serial Output Drops	Count of serial output drops because last output has not been completed.
Processing Latency	Last delay from camera exposure to when results can be scheduled to.
Max Processing Latency	Latency Maximum delay from camera exposure to when results can be scheduled to Rich I/O. Reset on start.
Camera Frame Count	Count of camera frame captured since the sensor was started.
Camera Search Count	Count of camera frame where laser is lost tracked. Only applicable when tracking window is enabled.
Valid Point Count	Count of valid spots detected in the last frame.
Part Count	Count of discrete parts.
Fixturing Invalid Count	Count of failed measurements because the live profile did not matched with the fixturing profile template.

## Measurement Statistics

Statistics are displayed for each measurement that has been configured on the **Measurement** page. Use the **Reset** button to reset the statistics.

The following information is available for each measurement:

### *Dashboard Measurement Statistics*

---

Name	Description
Value	The most recent measurement value.
Minimum/Maximum Value	The minimum and maximum measurement values that have been observed.
Average	The average of all measurement results collected since the sensor was started.
Standard Deviation	The standard deviation of all measurement results collected since the sensor was started.
Pass/Fail Count	The count of pass or fail decisions that have been generated.
Invalid Count	The count of frames that no feature points could be extracted from the live profile.

---

# Gocator Device Files

This section describes the Gocator's device files.

## Configuration Files

Configuration files contain settings that govern system behavior in the Running state.

Configurations are saved in XML format. Elements contain three types of values: settings, constraints, and properties. Settings are input values that can be edited. Constraints are read-only limits that define the valid values for settings. Properties are read-only values that provide supplemental information related to sensor setup.

When a configuration file is received from a sensor, it will contain settings, constraints, and properties. When a configuration file is sent to a sensor, any constraints or properties in the file will be ignored.

Changing the value of a setting can potentially affect multiple constraints and properties. After uploading a configuration file, the configuration file can be downloaded again to access updated values.

All Gocator sensors share a common configuration XML structure.

When editing the configuration file manually, you should only edit the elements that are applicable and leave the other elements in the structure.

## Setup

The Setup element contains settings related to system and sensor setup.

### *Setup Child Elements*

Element	Type	Description
StartupState	32s	Setting for the default state of the system at boot time: 0 - Ready 1 - Running
StartupModeOptions	String	Constraint for startup modes - comma-delimited list.
StartupMode	String	Setting for the default system mode at boot time.
XResamplingType	32s	Setting for the resampling interval: 0 - Maximum resolution 1 - Balanced 2 - Maximum speed
IntensityEnable	32u	Setting to disable or enable intensity output: 0 - Disable 1 - Enable

Element	Type	Description
XResamplingInterval	64f	Property for X resampling interval (mm).
AnalogGain	64f	Overrides the default camera analog gain. Set to -1 to use default value. [optional]
DigitalGain	64f	Overrides the default camera digital gain. Set to -1 to use default value. [optional]
TemperatureSafetyEnable	32u	Enables laser temperature safety on applicable sensors 0 - Disabled 1 - Enabled
SpotDetectionThreshold	32u	Overrides sensor default spot detection threshold. [optional]
SpotDetectionWidth	32u	Overrides sensor default spot max width. [optional]

## Trigger

The Trigger element contains settings related trigger source, speed, and encoder resolution.

### Trigger Child Elements

Element	Type	Description
TriggerSource	32s	Setting for trigger source: 0 - Time 1 - Encoder 2 - Input 3 - Software
SystemDomain	32s	Setting for units for trigger delay and output scheduling (Ignored when TriggerSource is Time or Encoder): 0 - Microseconds 1 - Millimeters
FrameRate	64f	Setting for frame rate (Hz) (Applicable for time-based triggering).
FullFrameRateEnable	32u	Setting to enable or disable full frame rate operation: 0 - Use FrameRate setting 1 - Ignore FrameRate setting, run at maximum frame rate
EncoderTriggerMode	32s	Setting for the encoder behavior: 0 - Track Reverse 1 - Ignore Reverse 2 - Bi-directional
EncoderPeriod	64f	Setting for encoder period (mm). (Applicable for encoder-based triggering)
TriggerDelay	64f	Setting for trigger delay (us or mm).
GateEnable	32u	Setting to disable or enable the use of digital input to gate the time or encoder trigger source: 0 - Disable 1 - Enable
BatchCount	32u	Number of frames to batch into one bundle.

<b>Element</b>	<b>Type</b>	<b>Description</b>
FrameRateMin	64f	Constraint for minimum frame rate (Hz).
FrameRateMax	64f	Constraint for maximum frame rate (Hz).
FrameRateMaxSource	32s	Source of maximum frame rate constraint: 0 - Imager 1 - Whole part memory usage
EncoderPeriodMin	64f	Constraint for minimum encoder period (ticks).
EncoderPeriodMax	64f	Constraint for maximum encoder period (ticks).
EncoderPeriodMinSource	32s	Source of minimum encoder period constraint: 0 - Encoder resolution 1 - Whole part memory usage
TriggerDelayMin	64f	Constraint for minimum trigger delay (us or ticks).
TriggerDelayMax	64f	Constraint for maximum trigger delay (us or ticks).
BatchCountMin	32u	Minimum batch count (frames).
BatchCountMax	32u	Maximum batch count (frames).

## Layout

The Layout element contains settings related to the layout/orientation of the system.

### *Layout Child Elements*

<b>Element</b>	<b>Type</b>	<b>Description</b>
Orientation	32s	Setting for orientation type: 0 - Isolated 1 - Wide 3 - Opposite
Overlap	32s	Setting for overlap: 0 - No overlap 1 - Overlap
BuddyReversed	32u	Setting for Buddy sensor's Y axis orientation (relative to the Main sensor) 0 - Not reversed 1 - Reversed
CalibratedX	64f	Property for system-calibrated active area X position (mm).
CalibratedZ	64f	Property for system-calibrated active area Z position (mm).
CalibratedWidth	64f	Property for system-calibrated active area width (mm).
CalibratedHeight	64f	Property for system-calibrated active area height (mm).

## Calibration

The Calibration element contains settings related to alignment and travel calibration.

### Calibration Child Elements

Element	Type	Description
AlignmentTarget	32s	Setting for alignment calibration target type: 0 - None 2 - Bar 3 - Plate
TravelTarget	32s	Setting for travel calibration target type: 1 - Disk 2 - Bar
CalibrationSource	32s	Setting for calibration source: 0 - Global 1 - Current Configuration
Disk/Diameter	64f	Setting for diameter of calibration disk (mm).
Disk/Height	64f	Setting for thickness of calibration disk (mm).
Bar/Height	64f	Setting for height of calibration bar (mm).
Bar/Width	64f	Setting for width of calibration bar (mm).
Bar/Holes	64f	Setting for number of holes on the calibration bar.
Bar/HoleDistance	64f	Setting for distance between calibration bar holes (mm).
Bar/HoleDiameter	64f	Setting for diameter of calibration bar holes (mm).

## Filters

The Filters element contains the settings related to post-processing the profiles before they are output or used by measurement tools.

### Filters Child Elements

Element	Type	Description
XSmoothing\Enable	32u	Setting to enable or disable X Smoothing filter: 0 - Disable 1 - Enable
XSmoothing\Window	64f	Setting for X Smoothing filter window (mm).
XSmoothing\WindowMin	64f	Constraint for minimum window size (mm).
XSmoothing\WindowMax	64f	Constraint for maximum window size (mm).
YSmoothing\Enable	32u	Setting for enable or disable Y Smoothing filter: 0 - Disable 1 - Enable
YSmoothing\Window	64f	Setting for YSmoothing filter window (mm).
YSmoothing\WindowMin	64f	Minimum window size (mm).
YSmoothing\WindowMax	64f	Maximum window size (mm).
XGapFilling\Enable	32u	Setting to enable or disable X Gap Filling filter: 0 - Disable 1 - Enable

Element	Type	Description
XGapFillingWindow	64f	Setting for X Gap Filling filter window (mm).
XGapFillingWindowMin	64f	Constraint for minimum window size (mm).
XGapFillingWindowMax	64f	Constraint for maximum window size (mm).
YGapFilling\Enable	32u	Setting for enable or disable Y Gap Filling filter: 0 – Disable 1 – Enable
YGapFillingWindow	64f	Setting for Y Gap Filling filter window (mm).
YGapFillingWindowMin	64f	Minimum window size (mm).
YGapFillingWindowMax	64f	Maximum window size (mm).

## Sensors / Sensor

Each Sensor element contains settings related to an individual sensor. A Sensor element has an attribute that defines the role (0 – Main, 1 – Buddy) of the sensor:

```
<Sensor role="0">
```

## Sensors / Sensor / Profiling

### Profiling Child Elements

Element	Type	Description
ExposureMode	32u	Setting for exposure mode: 0 – Single exposure 1 – Multiple exposures (for Gocator 2000 and 2300 series only) 2 – Dynamic exposure
ExposureDelay	32u	Setting for an optional delay (us) between triggering event and the actual start of the exposure. This is used for time multiplexing the sensors in a multi-sensor system.
ExposureStep	Collection	Collection of exposure steps.
ExposureStep/Step	64f	Setting for exposure steps (us).
Exposure	64f	Setting for exposure (us).
IntensityStepIndex	32u	Setting for the exposure step to use for intensity acquisition. Only applicable when multiple exposure mode is selected.
DynamicExposureMax	64f	Setting for maximum exposure (for dynamic exposure).
DynamicExposureMin	64f	Setting for minimum exposure (for dynamic exposure).
ActiveAreaX	64f	Setting for active area X position (mm).
ActiveAreaY	64f	Setting for active area Y position (mm).
ActiveAreaZ	64f	Setting for active area clearance distance (mm).
ActiveAreaWidth	64f	Setting for active area field of view (mm).

<b>Element</b>	<b>Type</b>	<b>Description</b>
ActiveAreaHeight	64f	Setting for active area measurement range (mm).
XSubsampling	32u	Setting for X resolution divider.
ZSubsampling	32u	Setting for Z resolution divider.
Filters	(Collection)	Contains elements XSmoothing and YSmoothing. See <i>Filters</i> (page 174).
ExposureTrainingEnabled	32u	Enables or disables exposure training. Only one sensor can be enabled when exposure training a buddy system. 0 – Disabled 1 – Enabled
ExposureTrainingStep	32u	Index of the exposure step whose value should be adjusted upon training completion.
ExposureMin	64f	Constraint for minimum exposure (us).
ExposureMax	64f	Constraint for maximum exposure (us).
ActiveAreaXMin	64f	Constraint for minimum X field of view boundary (mm).
ActiveAreaXMax	64f	Constraint for maximum X field of view boundary (mm).
ActiveAreaYMin	64f	Constraint for minimum Y field of view boundary (mm).
ActiveAreaYMax	64f	Constraint for maximum Y field of view boundary (mm).
ActiveAreaZMax	64f	Constraint for maximum Z field of view boundary (mm).
ActiveAreaZMin	64f	Constraint for minimum Z field of view boundary (mm).
ActiveAreaWidthMin	64f	Constraint for minimum field of view width (mm).
ActiveAreaWidthMax	64f	Constraint for maximum field of view width (mm).
ActiveAreaHeightMin	64f	Constraint for minimum field of view height (mm).
ActiveAreaHeightMax	64f	Constraint for maximum field of view height (mm).
XSubsamplingOptions	String	Constraint for X resolution divider options – comma-delimited list (e.g., "1,2").
ZSubsamplingOptions	String	Constraint for Z resolution divider options – comma-delimited list (e.g., "1,2").
FrontCameraX	32u	Property for x position of image ROI (pixels).
FrontCameraY	32u	Property for y position of image ROI (pixels).
FrontCameraWidth	32u	Property for width of image ROI (pixels).
FrontCameraHeight	32u	Property for height of image ROI (pixels).
CalibratedX	64f	Property for sensor calibrated active area X position (mm).
CalibratedY	64f	Property for sensor calibrated active area Y position (mm).
CalibratedZ	64f	Property for sensor calibrated active area Z position (mm).
CalibratedWidth	64f	Property for sensor calibrated active area width (mm).
CalibratedLength	64f	Property for sensor calibrated active area length (mm).

Element	Type	Description
CalibratedHeight	64f	Property for sensor calibrated active area height (mm).
Tracking\AreaHeightMin	64f	Constraint for minimum tracking window height
Tracking\AreaHeightMax	64f	Constraint for maximum tracking window height
Tracking\Enabled	32u	Enables or disable tracking support (2300 series only) 0 – Disable 1 – Enable
Tracking\SearchThreshold	64f	Tracking search threshold. Profiles are generated if the percentage of visible spots is equal or larger than the threshold.
Tracking\AreaHeight	64f	Height of the tracking window

## Profile

The Profile element contains settings that affect profile measurements. Simple child elements in Profile are defined below:

### Profile Child Elements

Element	Type	Description
MeasurementOptions	String	Constraint for available measurement types - comma-delimited list (e.g., "Width, Distance").

The Profile element also contains two significant sub-elements: Anchor and Measurements. The Anchor element defines profile anchoring behavior, while the Measurements element contains one sub-element for each requested profile measurement.

The id attribute associated with each measurement defines an identifier that must be unique among all measurements in the configuration file, for example:

```
<Width id="1001">
```

Most profile measurement elements contain one or more Area, Feature, or Line sub-elements. These common structures are described first.

The Id attribute of the Script tool is a comma-delimited list, for multiple output support.

## Area

An Area element defines a rectangular area of interest.

### Area Child Elements

Element	Type	Description
X	64f	Setting for area X position (mm).
Z	64f	Setting for area Z position (mm).
Width	64f	Setting for area width (mm).
Height	64f	Setting for area height (mm).

## Feature

A Feature element defines the settings for detecting a feature within an area of interest.

### *Feature Child Elements*

<b>Element</b>	<b>Type</b>	<b>Description</b>
Type	32s	Setting to determine how the feature is detected within the area: 0 - Top 1 - Bottom 2 - Right 3 - Left 4 - Corner 5 - Average 6 - Rising Edge 7 - Falling Edge 8 - Any Edge 9 - Top Corner 10 - Bottom Corner 11 - Left Corner 12 - Right Corner 13 - Median
Area	Area	Element for feature detection area.

## Line

A Line element defines measurement areas used to calculate a line.

### *Line Child Elements*

<b>Element</b>	<b>Type</b>	<b>Description</b>
Area[2]	Area	2 area elements used for line fitting.

## Anchor

An anchor element defines settings for anchoring (fixturing in the user interface).

### *Anchor Child Elements*

<b>Element</b>	<b>Type</b>	<b>Description</b>
ZEnable	32s	Setting for enable or disable Z fixturing.
XEnable	32s	Setting for enable or disable X fixturing
ZFeature\Type	32s	Setting to determine how the feature is detected within the area: 0 - Top 1 - Bottom 2 - Right 3 - Left 4 - Corner 5 - Average 6 - Rising Edge

Element	Type	Description
		7 - Falling Edge 8 - Any Edge 9 - Top Corner 10 - Bottom Corner 11 - Left Corner 12 - Right Corner 13 - Median
ZFeature\Area	Area	Area element used for anchoring.
XFeature\Type	32s	Setting to determine how the feature is detected within the area: 0 - Top 1 - Bottom 2 - Right 3 - Left 4 - Corner 5 - Average 6 - Rising Edge 7 - Falling Edge 8 - Any Edge 9 - Top Corner 10 - Bottom Corner 11 - Left Corner 12 - Right Corner 13 - Median
XFeature\Area	Area	Area element used for anchoring.

## Measurements / Width

A Width element defines settings for a profile width measurement.

### *Width Child Elements*

Element	Type	Description
Name	String	Setting for measurement name.
Source	32s	Setting for profile source.
DecisionMin	64f	Setting for decision threshold minimum (mm).
DecisionMax	64f	Setting for decision threshold maximum (mm).
AbsoluteResult	32u	Setting for selecting absolute or signed result: 0 - Signed result 1 - Absolute result
Feature[2]	Feature	Elements for feature detection.
LinkEnabled	32u	Setting to enable/disable linking 0 - Disable 1 - Enable

<b>Element</b>	<b>Type</b>	<b>Description</b>
Link	32u	Measurement ID to link with
Scale	64f	Setting for scale factor to apply to measurement value
Offset	64f	Setting for offset to apply to measurement value
SmoothingEnabled	32u	Setting to enable or disable the smoothing filter: 0 - Disable 1 - Enable
SmoothingWindow	32u	Setting for the smoothing window (frames)
HoldEnabled	32u	Setting to enable or disable the hold filter: 0 - Disable 1 - Enable
SourceOptions	String	Constraint for eligible profile sources (comma-delimited list).
SmoothingWindowMin	32u	Constraint for smoothing window minimum (frames)
SmoothingWindowMax	32u	Constraint for smoothing window maximum (frames)
LinkIds	32u	List of linkable measurements.

## Measurements / Height

A Height element defines settings for a profile height measurement.

### *Height Child Elements*

<b>Element</b>	<b>Type</b>	<b>Description</b>
Name	String	Setting for measurement name.
Source	32s	Setting for profile source.
DecisionMin	64f	Setting for decision threshold minimum (mm).
DecisionMax	64f	Setting for decision threshold maximum (mm).
AbsoluteResult	32u	Setting for selecting absolute or signed result: 0 - Signed result 1 - Absolute result
Feature[2]	Feature	Elements for feature detection.
LinkEnabled	32u	Setting to enable/disable linking 0 - Disable 1 - Enable
Link	32u	Measurement ID to link with
Scale	64f	Setting for scale factor to apply to measurement value
Offset	64f	Setting for offset to apply to measurement value
SmoothingEnabled	32u	Setting to enable or disable the smoothing filter: 0 - Disable 1 - Enable
SmoothingWindow	32u	Setting for the smoothing window (frames)
HoldEnabled	32u	Setting to enable or disable the hold filter:

Element	Type	Description
		0 - Disable 1 - Enable
SourceOptions	String	Constraint for eligible profile sources (comma-delimited list).
SmoothingWindowMin	32u	Constraint for smoothing window minimum (frames).
SmoothingWindowMax	32u	Constraint for smoothing window maximum (frames).
LinkIds	32u	List of linkable measurements.

## Measurements / Distance

A Distance element defines settings for a profile distance measurement.

### *Distance Child Elements*

Element	Type	Description
Name	String	Setting for measurement name.
Source	32s	Setting for profile source.
DecisionMin	64f	Setting for decision threshold minimum (mm).
DecisionMax	64f	Setting for decision threshold maximum (mm).
Feature[2]	Feature	Elements for feature detection.
LinkEnabled	32u	Setting to enable/disable linking: 0 - Disable 1 - Enable
Link	32u	Measurement ID to link with
Scale	64f	Setting for scale factor to apply to measurement value
Offset	64f	Setting for offset to apply to measurement value
SmoothingEnabled	32u	Setting to enable or disable the smoothing filter: 0 - Disable 1 - Enable
SmoothingWindow	32u	Setting for the smoothing window (frames)
HoldEnabled	32u	Setting to enable or disable the hold filter: 0 - Disable 1 - Enable
SourceOptions	String	Constraint for eligible profile sources (comma-delimited list).
SmoothingWindowMin	32u	Constraint for smoothing window minimum (frames).
SmoothingWindowMax	32u	Constraint for smoothing window maximum (frames).
LinkIds	32u	List of linkable measurements.

## Measurements / PositionX

A PositionX element defines settings for a profile X position measurement.

### *PositionX Child Elements*

<b>Element</b>	<b>Type</b>	<b>Description</b>
Name	String	Setting for measurement name.
Source	32s	Setting for profile source.
DecisionMin	64f	Setting for decision threshold minimum (mm).
DecisionMax	64f	Setting for decision threshold maximum (mm).
Feature	Feature	Element for feature detection.
LinkEnabled	32u	Setting to enable/disable linking: 0 – Disable 1 – Enable
Link	32u	Measurement ID to link with
Scale	64f	Setting for scale factor to apply to measurement value
Offset	64f	Setting for offset to apply to measurement value
SmoothingEnabled	32u	Setting to enable or disable the smoothing filter: 0 – Disable 1 – Enable
SmoothingWindow	32u	Setting for the smoothing window (frames)
HoldEnabled	32u	Setting to enable or disable the hold filter: 0 – Disable 1 – Enable
SourceOptions	String	Constraint for eligible profile sources (comma-delimited list).
SmoothingWindowMin	32u	Constraint for smoothing window minimum (frames).
SmoothingWindowMax	32u	Constraint for smoothing window maximum (frames).
LinkIds	32u	List of linkable measurements.

## **Measurements / PositionZ**

A PositionZ element defines settings for a profile Z position measurement.

### *PositionZ Child Elements*

<b>Element</b>	<b>Type</b>	<b>Description</b>
Name	String	Setting for measurement name.
Source	32s	Setting for profile source.
DecisionMin	64f	Setting for decision threshold minimum (mm).
DecisionMax	64f	Setting for decision threshold maximum (mm).
Feature	Feature	Element for feature detection.
LinkEnabled	32u	Setting to enable/disable linking: 0 – Disable 1 – Enable
Link	32u	Measurement ID to link with

<b>Element</b>	<b>Type</b>	<b>Description</b>
Scale	64f	Setting for scale factor to apply to measurement value
Offset	64f	Setting for offset to apply to measurement value
SmoothingEnabled	32u	Setting to enable or disable the smoothing filter: 0 - Disable 1 - Enable
SmoothingWindow	32u	Setting for the smoothing window (frames)
HoldEnabled	32u	Setting to enable or disable the hold filter: 0 - Disable 1 - Enable
SourceOptions	String	Constraint for eligible profile sources (comma-delimited list).
SmoothingWindowMin	32u	Constraint for smoothing window minimum (frames).
SmoothingWindowMax	32u	Constraint for smoothing window maximum (frames).
LinkIds	32u	List of linkable measurements.

## Measurements / CenterX

A CenterX element defines settings for a profile center-x measurement.

### *CenterX Child Elements*

<b>Element</b>	<b>Type</b>	<b>Description</b>
Name	String	Setting for measurement name.
Source	32s	Setting for profile source.
DecisionMin	64f	Setting for decision threshold minimum (mm).
DecisionMax	64f	Setting for decision threshold maximum (mm).
Feature[2]	Feature	Elements for feature detection.
LinkEnabled	32u	Setting to enable/disable linking: 0 - Disable 1 - Enable
Link	32u	Measurement ID to link with
Scale	64f	Setting for scale factor to apply to measurement value
Offset	64f	Setting for offset to apply to measurement value
SmoothingEnabled	32u	Setting to enable or disable the smoothing filter: 0 - Disable 1 - Enable
SmoothingWindow	32u	Setting for the smoothing window (frames)
HoldEnabled	32u	Setting to enable or disable the hold filter: 0 - Disable 1 - Enable
SourceOptions	String	Constraint for eligible profile sources (comma-delimited list).

Element	Type	Description
SmoothingWindowMin	32u	Constraint for smoothing window minimum (frames).
SmoothingWindowMax	32u	Constraint for smoothing window maximum (frames).
LinkIds	32u	List of linkable measurements.

## Measurements / CenterZ

A CenterZ element defines settings for a profile center-z measurement.

### CenterZ Child Elements

Element	Type	Description
Name	String	Setting for measurement name.
Source	32s	Setting for profile source.
DecisionMin	64f	Setting for decision threshold minimum (mm).
DecisionMax	64f	Setting for decision threshold maximum (mm).
Feature[2]	Feature	Elements for feature detection.
LinkEnabled	32u	Setting to enable/disable linking: 0 - Disable 1 - Enable
Link	32u	Measurement ID to link with
Scale	64f	Setting for scale factor to apply to measurement value
Offset	64f	Setting for offset to apply to measurement value
SmoothingEnabled	32u	Setting to enable or disable the smoothing filter: 0 - Disable 1 - Enable
SmoothingWindow	32u	Setting for the smoothing window (frames).
HoldEnabled	32u	Setting to enable or disable the hold filter: 0 - Disable 1 - Enable
SourceOptions	String	Constraint for eligible profile sources (comma-delimited list).
SmoothingWindowMin	32u	Constraint for smoothing window minimum (frames).
SmoothingWindowMax	32u	Constraint for smoothing window maximum (frames).
LinkIds	32u	List of linkable measurements.

## Measurements / AngleX

An AngleX element defines settings for a profile angle-x measurement.

### AngleX Child Elements

Element	Type	Description
Name	String	Setting for measurement name.
Source	32s	Setting for profile source.

<b>Element</b>	<b>Type</b>	<b>Description</b>
DecisionMin	64f	Setting for decision threshold minimum (degrees).
DecisionMax	64f	Setting for decision threshold maximum (degrees).
AbsoluteResult	32u	Setting for selecting absolute or signed result: 0 – Signed result 1 – Absolute result
Line	Line	Element for fit line.
LinkEnabled	32u	Setting to enable/disable linking: 0 – Disable 1 – Enable
Link	32u	Measurement ID to link with
Scale	64f	Setting for scale factor to apply to measurement value
Offset	64f	Setting for offset to apply to measurement value
SmoothingEnabled	32u	Setting to enable or disable the smoothing filter: 0 – Disable 1 – Enable
SmoothingWindow	32u	Setting for the smoothing window (frames)
HoldEnabled	32u	Setting to enable or disable the hold filter: 0 – Disable 1 – Enable
SourceOptions	String	Constraint for eligible profile sources (comma-delimited list).
SmoothingWindowMin	32u	Constraint for smoothing window minimum (frames).
SmoothingWindowMax	32u	Constraint for smoothing window maximum (frames).
LinkIds	32u	List of linkable measurements.

## Measurements / IntersectX

An IntersectX element defines settings for a profile intersect-x measurement.

### *IntersectX Child Elements*

<b>Element</b>	<b>Type</b>	<b>Description</b>
Name	String	Setting for measurement name.
Source	32s	Setting for profile source.
DecisionMin	64f	Setting for decision threshold minimum (mm).
DecisionMax	64f	Setting for decision threshold maximum (mm).
Line[2]	Line	Elements for fit lines.
LinkEnabled	32u	Setting to enable/disable linking: 0 – Disable 1 – Enable
Link	32u	Measurement ID to link with

<b>Element</b>	<b>Type</b>	<b>Description</b>
Scale	64f	Setting for scale factor to apply to measurement value
Offset	64f	Setting for offset to apply to measurement value
SmoothingEnabled	32u	Setting to enable or disable the smoothing filter: 0 - Disable 1 - Enable
SmoothingWindow	32u	Setting for the smoothing window (frames).
HoldEnabled	32u	Setting to enable or disable the hold filter: 0 - Disable 1 - Enable
SourceOptions	String	Constraint for eligible profile sources (comma-delimited list).
SmoothingWindowMin	32u	Constraint for smoothing window minimum (frames).
SmoothingWindowMax	32u	Constraint for smoothing window maximum (frames).
LinkIds	32u	List of linkable measurements.

## Measurements / IntersectZ

An IntersectZ element defines settings for a profile Intersect Z measurement.

### *IntersectZ Child Elements*

<b>Element</b>	<b>Type</b>	<b>Description</b>
Name	String	Setting for measurement name.
Source	32s	Setting for profile source.
DecisionMin	64f	Setting for decision threshold minimum (mm).
DecisionMax	64f	Setting for decision threshold maximum (mm).
Line[2]	Line	Elements for fit lines.
LinkEnabled	32u	Setting to enable/disable linking: 0 - Disable 1 - Enable
Link	32u	Measurement ID to link with
Scale	64f	Setting for scale factor to apply to measurement value
Offset	64f	Setting for offset to apply to measurement value
SmoothingEnabled	32u	Setting to enable or disable the smoothing filter: 0 - Disable 1 - Enable
SmoothingWindow	32u	Setting for the smoothing window (frames)
HoldEnabled	32u	Setting to enable or disable the hold filter: 0 - Disable 1 - Enable
SourceOptions	String	Constraint for eligible profile sources (comma-delimited list).

Element	Type	Description
SmoothingWindowMin	32u	Constraint for smoothing window minimum (frames).
SmoothingWindowMax	32u	Constraint for smoothing window maximum (frames).
LinkId	32u	List of linkable measurements.

## Measurements / IntersectAngle

An IntersectAngle element defines settings for a profile intersect angle measurement.

### *IntersectAngle Child Elements*

Element	Type	Description
Name	String	Setting for measurement name.
Source	32s	Setting for profile source.
DecisionMin	64f	Setting for decision threshold minimum (degrees).
DecisionMax	64f	Setting for decision threshold maximum (degrees).
AbsoluteResult	32u	Setting for selecting absolute or signed result: 0 - Signed result 1 - Absolute result
Line[2]	Line	Elements for fit lines.
LinkEnabled	32u	Setting to enable/disable linking: 0 - Disable 1 - Enable
Link	32u	Measurement ID to link with
Scale	64f	Setting for scale factor to apply to measurement value
Offset	64f	Setting for offset to apply to measurement value
SmoothingEnabled	32u	Setting to enable or disable the smoothing filter: 0 - Disable 1 - Enable
SmoothingWindow	32u	Setting for the smoothing window (frames)
HoldEnabled	32u	Setting to enable or disable the hold filter: 0 - Disable 1 - Enable
SourceOptions	String	Constraint for eligible profile sources (comma-delimited list).
SmoothingWindowMin	32u	Constraint for smoothing window minimum (frames).
SmoothingWindowMax	32u	Constraint for smoothing window maximum (frames).
LinkId	32u	List of linkable measurements.

## Measurements / IntersectArea

An IntersectArea element defines settings for a profile intersect area measurement.

### *IntersectArea Child Elements*

<b>Element</b>	<b>Type</b>	<b>Description</b>
Name	String	Setting for measurement name.
Source	32s	Setting for profile source.
DecisionMin	64f	Setting for decision threshold minimum (mm).
DecisionMax	64f	Setting for decision threshold maximum (mm).
Area	Area	Element for measurement area.
Line	Line	Element for measurement baseline.
LinkEnabled	32u	Setting to enable/disable linking: 0 – Disable 1 – Enable
Link	32u	Measurement ID to link with
Scale	64f	Setting for scale factor to apply to measurement value
Offset	64f	Setting for offset to apply to measurement value
SmoothingEnabled	32u	Setting to enable or disable the smoothing filter: 0 – Disable 1 – Enable
SmoothingWindow	32u	Setting for the smoothing window (frames)
HoldEnabled	32u	Setting to enable or disable the hold filter: 0 – Disable 1 – Enable
SourceOptions	String	Constraint for eligible profile sources (comma-delimited list).
SmoothingWindowMin	32u	Constraint for smoothing window minimum (frames).
SmoothingWindowMax	32u	Constraint for smoothing window maximum (frames).
LinkIds	32u	List of linkable measurements.

## **Measurements / BoxArea**

A BoxArea element defines settings for a profile box area measurement.

### *BoxArea Child Elements*

<b>Element</b>	<b>Type</b>	<b>Description</b>
Name	String	Setting for measurement name.
Source	32s	Setting for profile source.
DecisionMin	64f	Setting for decision threshold minimum (mm).
DecisionMax	64f	Setting for decision threshold maximum (mm).
Area	Area	Element for measurement area.
LinkEnabled	32u	Setting to enable/disable linking: 0 – Disable 1 – Enable

<b>Element</b>	<b>Type</b>	<b>Description</b>
Link	32u	Measurement ID to link with
Scale	64f	Setting for scale factor to apply to measurement value
Offset	64f	Setting for offset to apply to measurement value
SmoothingEnabled	32u	Setting to enable or disable the smoothing filter: 0 - Disable 1 - Enable
SmoothingWindow	32u	Setting for the smoothing window (frames)
HoldEnabled	32u	Setting to enable or disable the hold filter: 0 - Disable 1 - Enable
SourceOptions	String	Constraint for eligible profile sources (comma-delimited list).
SmoothingWindowMin	32u	Constraint for smoothing window minimum (frames).
SmoothingWindowMax	32u	Constraint for smoothing window maximum (frames).
LinkIds	32u	List of linkable measurements.

## Measurements / Difference Area

A difference area element defines settings for difference area measurement.

### *Difference Area Child Elements*

<b>Element</b>	<b>Type</b>	<b>Description</b>
Name	String	Setting for measurement name.
DecisionMin	64f	Setting for decision threshold minimum (mm2).
DecisionMax	64f	Setting for decision threshold maximum (mm2).
AbsoluteResult	32u	Setting for selecting absolute or signed result: 0 - Signed result 1 - Absolute result
Source	32s	Setting for profile source.
Area	Area	Element for measurement area.
LinkEnabled	32u	Setting to enable/disable linking: 0 - Disable 1 - Enable
Link	32u	Measurement ID to link with
Scale	64f	Setting for scale factor to apply to measurement value
Offset	64f	Setting for offset to apply to measurement value
SmoothingEnabled	32u	Setting to enable or disable the smoothing filter: 0 - Disable 1 - Enable
SmoothingWindow	32u	Setting for the smoothing window (frames)
HoldEnabled	32u	Setting to enable or disable the hold filter:

Element	Type	Description
		0 – Disable 1 – Enable
SourceOptions	String	Constraint for eligible profile sources (comma-delimited list).
SmoothingWindowMin	32u	Constraint for smoothing window minimum (frames).
SmoothingWindowMax	32u	Constraint for smoothing window maximum (frames).
LinkId	32u	List of linkable measurements.

## Measurements / Difference Peak

A difference peak element defines settings for difference peak measurement.

### *Difference Peak Child Elements*

Element	Type	Description
Name	String	Setting for measurement name.
DecisionMin	64f	Setting for decision threshold minimum (mm).
DecisionMax	64f	Setting for decision threshold maximum (mm).
AbsoluteResult	32u	Setting for selecting absolute or signed result: 0 – Signed result 1 – Absolute result
Source	32s	Setting for profile source.
Area	Area	Element for measurement area.
LinkEnabled	32u	Setting to enable/disable linking: 0 – Disable 1 – Enable
Link	32u	Measurement ID to link with
Scale	64f	Setting for scale factor to apply to measurement value
Offset	64f	Setting for offset to apply to measurement value
SmoothingEnabled	32u	Setting to enable or disable the smoothing filter: 0 – Disable 1 – Enable
SmoothingWindow	32u	Setting for the smoothing window (frames)
HoldEnabled	32u	Setting to enable or disable the hold filter: 0 – Disable 1 – Enable
SourceOptions	String	Constraint for eligible profile sources (comma-delimited list).
SmoothingWindowMin	32u	Constraint for smoothing window minimum (frames).
SmoothingWindowMax	32u	Constraint for smoothing window maximum (frames).
LinkId	32u	List of linkable measurements.

## Measurements / Circle Radius

A CircleRadius element defines settings for a profile circle radius measurement.

### CircleRadius Child Elements

Element	Type	Description
Name	String	Setting for measurement name.
Source	32s	Setting for profile source.
DecisionMin	64f	Setting for decision threshold minimum (mm).
DecisionMax	64f	Setting for decision threshold maximum (mm).
Area	Area	Element for measurement area.
LinkEnabled	32u	Setting to enable/disable linking: 0 – Disable 1 – Enable
Link	32u	Measurement ID to link with
Scale	64f	Setting for scale factor to apply to measurement value
Offset	64f	Setting for offset to apply to measurement value
SmoothingEnabled	32u	Setting to enable or disable the smoothing filter: 0 – Disable 1 – Enable
SmoothingWindow	32u	Setting for the smoothing window (frames)
HoldEnabled	32u	Setting to enable or disable the hold filter: 0 – Disable 1 – Enable
SourceOptions	String	Constraint for eligible profile sources (comma-delimited list).
SmoothingWindowMin	32u	Constraint for smoothing window minimum (frames).
SmoothingWindowMax	32u	Constraint for smoothing window maximum (frames).
LinkIds	32u	List of linkable measurements.

## Measurements / Circle X

A CircleX element defines settings for a profile circle center X measurement.

### CircleX Child Elements

Element	Type	Description
Name	String	Setting for measurement name.
Source	32s	Setting for profile source.
DecisionMin	64f	Setting for decision threshold minimum (mm).
DecisionMax	64f	Setting for decision threshold maximum (mm).
Area	Area	Element for measurement area.
LinkEnabled	32u	Setting to enable/disable linking: 0 – Disable 1 – Enable
Link	32u	Measurement ID to link with

<b>Element</b>	<b>Type</b>	<b>Description</b>
Scale	64f	Setting for scale factor to apply to measurement value
Offset	64f	Setting for offset to apply to measurement value
SmoothingEnabled	32u	Setting to enable or disable the smoothing filter: 0 - Disable 1 - Enable
SmoothingWindow	32u	Setting for the smoothing window (frames)
HoldEnabled	32u	Setting to enable or disable the hold filter: 0 - Disable 1 - Enable
SourceOptions	String	Constraint for eligible profile sources (comma-delimited list).
SmoothingWindowMin	32u	Constraint for smoothing window minimum (frames).
SmoothingWindowMax	32u	Constraint for smoothing window maximum (frames).
LinkIds	32u	List of linkable measurements.

## Measurements / Circle Z

A CircleZ element defines settings for a profile circle center Z measurement.

### *CircleZ Child Elements*

<b>Element</b>	<b>Type</b>	<b>Description</b>
Name	String	Setting for measurement name.
Source	32s	Setting for profile source.
DecisionMin	64f	Setting for decision threshold minimum (mm).
DecisionMax	64f	Setting for decision threshold maximum (mm).
Area	Area	Element for measurement area.
LinkEnabled	32u	Setting to enable/disable linking: 0 - Disable 1 - Enable
Link	32u	Measurement ID to link with
Scale	64f	Setting for scale factor to apply to measurement value
Offset	64f	Setting for offset to apply to measurement value
SmoothingEnabled	32u	Setting to enable or disable the smoothing filter: 0 - Disable 1 - Enable
SmoothingWindow	32u	Setting for the smoothing window (frames)
HoldEnabled	32u	Setting to enable or disable the hold filter: 0 - Disable 1 - Enable
SourceOptions	String	Constraint for eligible profile sources (comma-delimited list).

Element	Type	Description
SmoothingWindowMin	32u	Constraint for smoothing window minimum (frames).
SmoothingWindowMax	32u	Constraint for smoothing window maximum (frames).
LinkIds	32u	List of linkable measurements.

## Measurements / Line Standard Deviation

A LineStdDev element defines settings for a profile line standard deviation measurement.

### LineStdDev Child Elements

Element	Type	Description
Name	String	Setting for measurement name.
Source	32s	Setting for profile source.
DecisionMin	64f	Setting for decision threshold minimum (mm).
DecisionMax	64f	Setting for decision threshold maximum (mm).
Area	Area	Element for measurement area.
LinkEnabled	32u	Setting to enable/disable linking: 0 - Disable 1 - Enable
Link	32u	Measurement ID to link with
Scale	64f	Setting for scale factor to apply to measurement value
Offset	64f	Setting for offset to apply to measurement value
SmoothingEnabled	32u	Setting to enable or disable the smoothing filter: 0 - Disable 1 - Enable
SmoothingWindow	32u	Setting for the smoothing window (frames)
HoldEnabled	32u	Setting to enable or disable the hold filter: 0 - Disable 1 - Enable
SourceOptions	String	Constraint for eligible profile sources (comma-delimited list).
SmoothingWindowMin	32u	Constraint for smoothing window minimum (frames).
SmoothingWindowMax	32u	Constraint for smoothing window maximum (frames).
LinkIds	32u	List of linkable measurements.

## Measurements / Line Error Min

A LineErrorMin element defines settings for a profile line error min measurement.

### LineErrorMin Child Elements

Element	Type	Description
Name	String	Setting for measurement name.
Source	32s	Setting for profile source.

<b>Element</b>	<b>Type</b>	<b>Description</b>
DecisionMin	64f	Setting for decision threshold minimum (mm).
DecisionMax	64f	Setting for decision threshold maximum (mm).
Area	Area	Element for measurement area.
LinkEnabled	32u	Setting to enable/disable linking: 0 - Disable 1 - Enable
Link	32u	Measurement ID to link with
Scale	64f	Setting for scale factor to apply to measurement value
Offset	64f	Setting for offset to apply to measurement value
SmoothingEnabled	32u	Setting to enable or disable the smoothing filter: 0 - Disable 1 - Enable
SmoothingWindow	32u	Setting for the smoothing window (frames)
HoldEnabled	32u	Setting to enable or disable the hold filter: 0 - Disable 1 - Enable
SourceOptions	String	Constraint for eligible profile sources (comma-delimited list).
SmoothingWindowMin	32u	Constraint for smoothing window minimum (frames).
SmoothingWindowMax	32u	Constraint for smoothing window maximum (frames).
LinkIds	32u	List of linkable measurements.

## Measurements / Line Error Max

A LineErrorMax element defines settings for a profile line error max measurement.

### *LineErrorMax Child Elements*

<b>Element</b>	<b>Type</b>	<b>Description</b>
Name	String	Setting for measurement name.
Source	32s	Setting for profile source.
DecisionMin	64f	Setting for decision threshold minimum (mm).
DecisionMax	64f	Setting for decision threshold maximum (mm).
Area	Area	Element for measurement area.
LinkEnabled	32u	Setting to enable/disable linking: 0 - Disable 1 - Enable
Link	32u	Measurement ID to link with
Scale	64f	Setting for scale factor to apply to measurement value
Offset	64f	Setting for offset to apply to measurement value
SmoothingEnabled	32u	Setting to enable or disable the smoothing filter:

Element	Type	Description
		0 - Disable 1 - Enable
SmoothingWindow	32u	Setting for the smoothing window (frames)
HoldEnabled	32u	Setting to enable or disable the hold filter: 0 - Disable 1 - Enable
SourceOptions	String	Constraint for eligible profile sources (comma-delimited list).
SmoothingWindowMin	32u	Constraint for smoothing window minimum (frames).
SmoothingWindowMax	32u	Constraint for smoothing window maximum (frames).
LinkIds	32u	List of linkable measurements.

## Measurements / Line Percentile

A LinePercentile element defines settings for a profile line percentile measurement.

### *LinePercentile Child Elements*

Element	Type	Description
Name	String	Setting for measurement name.
Source	32s	Setting for profile source.
DecisionMin	64f	Setting for decision threshold minimum (mm).
DecisionMax	64f	Setting for decision threshold maximum (mm).
Area	Area	Element for measurement area.
Percentile	64f	Error percentile
LinkEnabled	32u	Setting to enable/disable linking: 0 - Disable 1 - Enable
Link	32u	Measurement ID to link with
Scale	64f	Setting for scale factor to apply to measurement value
Offset	64f	Setting for offset to apply to measurement value
SmoothingEnabled	32u	Setting to enable or disable the smoothing filter: 0 - Disable 1 - Enable
SmoothingWindow	32u	Setting for the smoothing window (frames)
HoldEnabled	32u	Setting to enable or disable the hold filter: 0 - Disable 1 - Enable
SourceOptions	String	Constraint for eligible profile sources (comma-delimited list).
SmoothingWindowMin	32u	Constraint for smoothing window minimum (frames).
SmoothingWindowMax	32u	Constraint for smoothing window maximum (frames).
LinkIds	32u	List of linkable measurements.

## Measurements / Gap

A Gap element defines settings for a profile gap measurement.

### Gap Child Elements

Element	Type	Description
Name	String	Setting for measurement name.
Source	32s	Setting for profile source.
DecisionMin	64f	Setting for decision threshold minimum (mm).
DecisionMax	64f	Setting for decision threshold maximum (mm).
ReferenceSide	32s	Setting for reference Side: 0 - Left 1 - Right
GapWidthMax	64f	Setting for maximum gap width (mm).
MeasurementAxis	32s	Setting for measurement axis: 0 - Edge 1 - Surface 2 - Distance
LeftSide	Side	Element for left side configuration.
RightSide	Side	Element for right side configuration.
LinkEnabled	32u	Setting to enable/disable linking: 0 - Disable 1 - Enable
Link	32u	Measurement ID to link with
Scale	64f	Setting for scale factor to apply to measurement value
Offset	64f	Setting for offset to apply to measurement value
SmoothingEnabled	32u	Setting to enable or disable the smoothing filter: 0 - Disable 1 - Enable
SmoothingWindow	32u	Setting for the smoothing window (frames)
HoldEnabled	32u	Setting to enable or disable the hold filter: 0 - Disable 1 - Enable
SourceOptions	String	Constraint for eligible profile sources (comma-delimited list).
SmoothingWindowMin	32u	Constraint for smoothing window minimum (frames).
SmoothingWindowMax	32u	Constraint for smoothing window maximum (frames).
LinkIds	32u	List of linkable measurements.

### Side Child Elements

Element	Type	Description
DepthMin	64f	Setting for minimum depth (mm).

<b>Element</b>	<b>Type</b>	<b>Description</b>
VoidWidthMax	64f	Setting for maximum void width (mm).
SurfaceWidth	64f	Setting for surface width (mm).
SurfaceOffset	64f	Setting for surface offset (mm).
NominalRadius	64f	Setting for nominal radius (mm).
EdgeAngle	64f	Setting for edge angle (deg)
EdgeType	32s	Setting for type of edge: 0 - Tangent 1 - Corner
Area	Area	Element for measurement area

## Measurements / Flush

A Flush element defines settings for a profile flush measurement.

### *Flush Child Elements*

<b>Element</b>	<b>Type</b>	<b>Description</b>
Name	String	Setting for measurement name.
Source	32s	Setting for profile source.
DecisionMin	64f	Setting for decision threshold minimum (mm).
DecisionMax	64f	Setting for decision threshold maximum (mm).
ReferenceSide	32s	Setting for reference Side: 0 - Left 1 - Right
GapWidthMax	64f	Setting for maximum gap width (mm).
LeftSide	Side	Element for left side configuration.
RightSide	Side	Element for right side configuration.
LinkEnabled	32u	Setting to enable/disable linking 0 - Disable 1 - Enable
Link	32u	Measurement ID to link with
Scale	64f	Setting for scale factor to apply to measurement value
Offset	64f	Setting for offset to apply to measurement value
SmoothingEnabled	32u	Setting to enable or disable the smoothing filter: 0 - Disable 1 - Enable
SmoothingWindow	32u	Setting for the smoothing window (frames)
HoldEnabled	32u	Setting to enable or disable the hold filter: 0 - Disable 1 - Enable

<b>Element</b>	<b>Type</b>	<b>Description</b>
SourceOptions	String	Constraint for eligible profile sources (comma-delimited list).
SmoothingWindowMin	32u	Constraint for smoothing window minimum (frames).
SmoothingWindowMax	32u	Constraint for smoothing window maximum (frames).
LinkId	32u	List of linkable measurements.

#### *Side Child Elements*

<b>Element</b>	<b>Type</b>	<b>Description</b>
DepthMin	64f	Setting for minimum depth (mm).
VoidWidthMax	64f	Setting for maximum void width (mm).
SurfaceWidth	64f	Setting for surface width (mm).
SurfaceOffset	64f	Setting for surface offset (mm).
NominalRadius	64f	Setting for nominal radius (mm).
EdgeAngle	64f	Setting for edge angle.
EdgeType	32s	Setting for type of edge: 0 - Tangent 1 - Corner
Area	Area	Element for measurement area.

## Measurements / Groove Width

A Groove width element defines settings for a profile groove width measurement.

#### *GrooveWidth Child Elements*

<b>Element</b>	<b>Type</b>	<b>Description</b>
Name	String	Setting for measurement name.
Source	32s	Setting for profile source.
DecisionMin	64f	Setting for decision threshold minimum (mm).
DecisionMax	64f	Setting for decision threshold maximum (mm).
Area	Area	Element for measurement area.
Shape	32s	Setting for shape of the groove: 0 - V-shaped 1 - U-shaped 2 - Open shaped
SelectType	32s	Setting for selecting a groove out of multiple grooves: 0 - Maximum depth 1 - 0-based index, from left to right 2 - 0-based index, from right to left
SelectN	32u	Index when SelectType is set to 1 or 2.
WidthMin	64f	Setting for minimum groove width (mm).
WidthMax	64f	Setting for maximum groove width (mm).

<b>Element</b>	<b>Type</b>	<b>Description</b>
DepthMin	64f	Setting for minimum groove depth (mm).
LinkEnabled	32u	Setting to enable/disable linking: 0 – Disable 1 – Enable
Link	32u	Measurement ID to link with
Scale	64f	Setting for scale factor to apply to measurement value
Offset	64f	Setting for offset to apply to measurement value
SmoothingEnabled	32u	Setting to enable or disable the smoothing filter: 0 – Disable 1 – Enable
SmoothingWindow	32u	Setting for the smoothing window (frames)
HoldEnabled	32u	Setting to enable or disable the hold filter: 0 – Disable 1 – Enable
SourceOptions	String	Constraint for eligible profile sources (comma-delimited list).
SmoothingWindowMin	32u	Constraint for smoothing window minimum (frames).
SmoothingWindowMax	32u	Constraint for smoothing window maximum (frames).
LinkIds	32u	List of linkable measurements.

## Measurements / Groove X

A Groove X element defines settings for a profile groove X measurement.

### *Groove X Child Elements*

<b>Element</b>	<b>Type</b>	<b>Description</b>
Name	String	Setting for measurement name.
Source	32s	Setting for profile source.
DecisionMin	64f	Setting for decision threshold minimum (mm).
DecisionMax	64f	Setting for decision threshold maximum (mm).
Area	Area	Element for measurement area.
Shape	32s	Setting for shape of the groove: 0 – V-shaped 1 – U-shaped 2 – Open shaped
SelectType	32s	Setting for selecting a groove out of multiple grooves. 0 – Maximum depth 1 – 0-based index, from left to right 2 – 0-based index, from right to left
SelectN	32u	Index when SelectType is set to 1 or 2.
WidthMin	64f	Setting for minimum groove width (mm).

<b>Element</b>	<b>Type</b>	<b>Description</b>
WidthMax	64f	Setting for maximum groove width (mm).
DepthMin	64f	Setting for minimum groove depth (mm).
Location	32s	Setting for groove location to return from: 0 - Bottom 1 - Left corner 2 - Right corner
LinkEnabled	32u	Setting to enable/disable linking: 0 - Disable 1 - Enable
Link	32u	Measurement ID to link with
Scale	64f	Setting for scale factor to apply to measurement value
Offset	64f	Setting for offset to apply to measurement value
SmoothingEnabled	32u	Setting to enable or disable the smoothing filter: 0 - Disable 1 - Enable
SmoothingWindow	32u	Setting for the smoothing window (frames).
HoldEnabled	32u	Setting to enable or disable the hold filter: 0 - Disable 1 - Enable
SourceOptions	String	Constraint for eligible profile sources (comma-delimited list).
SmoothingWindowMin	32u	Constraint for smoothing window minimum (frames).
SmoothingWindowMax	32u	Constraint for smoothing window maximum (frames).
LinkIds	32u	List of linkable measurements.

## Measurements / Groove Z

A Groove Z element defines settings for a profile groove Z measurement.

### *Groove Z Child Elements*

<b>Element</b>	<b>Type</b>	<b>Description</b>
Name	String	Setting for measurement name.
Source	32s	Setting for profile source.
DecisionMin	64f	Setting for decision threshold minimum (mm).
DecisionMax	64f	Setting for decision threshold maximum (mm).
Area	Area	Element for measurement area.
Shape	32s	Setting for shape of the groove: 0 - V-shaped 1 - U-shaped
SelectType	32s	Setting for selecting a groove out of multiple grooves: 0 - Maximum depth

Element	Type	Description
		1 - 0-based index, from left to right 2 - 0-based index, from right to left
SelectN	32u	Index when SelectType is set to 1 or 2.
WidthMin	64f	Setting for minimum groove width (mm).
WidthMax	64f	Setting for maximum groove width (mm).
DepthMin	64f	Setting for minimum groove depth (mm).
Location	32s	Setting for groove location to return from: 0 - Bottom 1 - Left corner 2 - Right corner
LinkEnabled	32u	Setting to enable/disable linking 0 - Disable 1 - Enable
Link	32u	Measurement ID to link with
Scale	64f	Setting for scale factor to apply to measurement value
Offset	64f	Setting for offset to apply to measurement value
SmoothingEnabled	32u	Setting to enable or disable the smoothing filter: 0 - Disable 1 - Enable
SmoothingWindow	32u	Setting for the smoothing window (frames)
HoldEnabled	32u	Setting to enable or disable the hold filter: 0 - Disable 1 - Enable
SourceOptions	String	Constraint for eligible profile sources (comma-delimited list).
SmoothingWindowMin	32u	Constraint for smoothing window minimum (frames).
SmoothingWindowMax	32u	Constraint for smoothing window maximum (frames).
LinkIds	32u	List of linkable measurements.

## Measurements / Groove Depth

A Groove Depth element defines settings for a profile groove depth measurement.

### *Groove Depth Child Elements*

Element	Type	Description
Name	String	Setting for measurement name.
Source	32s	Setting for profile source.
DecisionMin	64f	Setting for decision threshold minimum (mm).
DecisionMax	64f	Setting for decision threshold maximum (mm).
Area	Area	Element for measurement area.
Shape	32s	Setting for shape of the groove:

Element	Type	Description
		0 - V-shaped 1 - U-shaped 2 - Open shaped
SelectType	32s	Setting for selecting a groove out of multiple grooves: 0 - Maximum depth 1 - 0-based index, from left to right 2 - 0-based index, from right to left
SelectN	32u	Index when SelectType is set to 1 or 2.
WidthMin	64f	Setting for minimum groove width (mm).
WidthMax	64f	Setting for maximum groove width (mm).
DepthMin	64f	Setting for minimum groove depth (mm).
LinkEnabled	32u	Setting to enable/disable linking: 0 - Disable 1 - Enable
Link	32u	Measurement ID to link with
Scale	64f	Setting for scale factor to apply to measurement value
Offset	64f	Setting for offset to apply to measurement value
SmoothingEnabled	32u	Setting to enable or disable the smoothing filter: 0 - Disable 1 - Enable
SmoothingWindow	32u	Setting for the smoothing window (frames)
HoldEnabled	32u	Setting to enable or disable the hold filter: 0 - Disable 1 - Enable
SourceOptions	String	Constraint for eligible profile sources (comma-delimited list).
SmoothingWindowMin	32u	Constraint for smoothing window minimum (frames).
SmoothingWindowMax	32u	Constraint for smoothing window maximum (frames).
LinkIds	32u	List of linkable measurements.

## Measurements / Strip X

A Strip X element defines settings for a profile strip X measurement.

### *Strip X Child Elements*

Element	Type	Description
Name	String	Setting for measurement name.
Source	32s	Setting for profile source.
DecisionMin	64f	Setting for decision threshold minimum (mm).
DecisionMax	64f	Setting for decision threshold maximum (mm).
Area	Area	Element for measurement area.

<b>Element</b>	<b>Type</b>	<b>Description</b>
Location	32s	Setting for the location of the strip: 0 - Left 1 - Right 2 - Center
BaseType	32s	Setting for the strip type: 0 - None 1 - Flat
LeftEdgeType	32s	Setting of the left edge conditions: 0 - Rising 1 - Falling 2 - Data End 3 - Void
RightEdgeType	32s	Setting of the left edge conditions 0 - Rising 1 - Falling 2 - Data End 3 - Void
SelectType	32s	Setting for selecting a strip out of multiple strips. 0 - Best 1 - 0-based index, from left to right 2 - 0-based index, from right to left
SelectN	32u	Index when SelectType is set to 1 or 2.
TiltEnabled	32u	Setting for tilt compensation 0 - Disabled 1 - Enabled
EdgeHeightMin	64f	Setting for minimum edge height width (mm).
EdgeTransitionWidth	64f	Setting for edge transition width (mm).
EdgeSupportWidth	64f	Setting for edge support width (mm).
VoidMax	64f	Setting for maximum void (mm).
WidthMin	64f	Setting for minimum strip width (mm).
EdgeTransitionWidthMax	64f	Constraint for edge transition width maximum (mm).
VoidMaxLimitMax	64f	Constraint for maximum void (mm).
LinkEnabled	32u	Setting to enable/disable linking: 0 - Disable 1 - Enable
Link	32u	Measurement ID to link with
Scale	64f	Setting for scale factor to apply to measurement value
Offset	64f	Setting for offset to apply to measurement value
SmoothingEnabled	32u	Setting to enable or disable the smoothing filter:

Element	Type	Description
		0 - Disable 1 - Enable
SmoothingWindow	32u	Setting for the smoothing window (frames)
HoldEnabled	32u	Setting to enable or disable the hold filter: 0 - Disable 1 - Enable
SourceOptions	String	Constraint for eligible profile sources (comma-delimited list).
SmoothingWindowMin	32u	Constraint for smoothing window minimum (frames).
SmoothingWindowMax	32u	Constraint for smoothing window maximum (frames).
LinkIds	32u	List of linkable measurements.

## Measurements / Strip Z

A Strip Z element defines settings for a profile strip Z measurement.

### Strip Z Child Elements

Element	Type	Description
Name	String	Setting for measurement name.
Source	32s	Setting for profile source.
DecisionMin	64f	Setting for decision threshold minimum (mm).
DecisionMax	64f	Setting for decision threshold maximum (mm).
Area	Area	Element for measurement area.
Location	32s	Setting for the location of the strip: 0 - Left 1 - Right 2 - Center
BaseType	32s	Setting for the strip type: 0 - None 1 - Flat
LeftEdgeType	32s	Setting of the left edge conditions: 1 - Rising 2 - Falling 4 - Data End 8 - Void Multiple values can be selected by adding the selections.
RightEdgeType	32s	Setting of the left edge conditions: 1 - Rising 2 - Falling 4 - Data End 8 - Void Multiple values can be selected by adding the selections.

<b>Element</b>	<b>Type</b>	<b>Description</b>
SelectType	32s	Setting for selecting a strip out of multiple strips. 0 – Best 1 – 0-based index, from left to right 2 – 0-based index, from right to left
SelectN	32u	Index when SelectType is set to 1 or 2.
TiltEnabled	32u	Setting for tilt compensation 0 – Disabled 1 – Enabled
EdgeHeightMin	64f	Setting for minimum edge height width (mm).
EdgeTransitionWidth	64f	Setting for edge transition width (mm).
EdgeSupportWidth	64f	Setting for edge support width (mm).
VoidMax	64f	Setting for maximum void (mm).
WidthMin	64f	Setting for minimum strip width (mm).
EdgeTransitionWidthMax	64f	Constraint for edge transition width maximum (mm).
VoidMaxLimitMax	64f	Constraint for maximum void (mm).
LinkEnabled	32u	Setting to enable/disable linking: 0 – Disable 1 – Enable
Link	32u	Measurement ID to link with
Scale	64f	Setting for scale factor to apply to measurement value
Offset	64f	Setting for offset to apply to measurement value
SmoothingEnabled	32u	Setting to enable or disable the smoothing filter: 0 – Disable 1 – Enable
SmoothingWindow	32u	Setting for the smoothing window (frames)
HoldEnabled	32u	Setting to enable or disable the hold filter: 0 – Disable 1 – Enable
SourceOptions	String	Constraint for eligible profile sources (comma-delimited list).
SmoothingWindowMin	32u	Constraint for smoothing window minimum (frames).
SmoothingWindowMax	32u	Constraint for smoothing window maximum (frames).
LinkIds	32u	List of linkable measurements.

## Measurements / Strip Width

A Strip Width element defines settings for a profile strip width measurement.

### *Strip Width Child Elements*

<b>Element</b>	<b>Type</b>	<b>Description</b>
Name	String	Setting for measurement name.

<b>Element</b>	<b>Type</b>	<b>Description</b>
Source	32s	Setting for profile source.
DecisionMin	64f	Setting for decision threshold minimum (mm).
DecisionMax	64f	Setting for decision threshold maximum (mm).
Area	Area	Element for measurement area.
BaseType	32s	Setting for the strip type: 0 - None 1 - Flat
LeftEdgeType	32s	Setting of the left edge conditions: 0 - Rising 1 - Falling 2 - Data End 3 - Void
RightEdgeType	32s	Setting of the left edge conditions: 0 - Rising 1 - Falling 2 - Data End 3 - Void
SelectType	32s	Setting for selecting a strip out of multiple strips. 0 - Best 1 - 0-based index, from left to right 2 - 0-based index, from right to left
SelectN	32u	Index when SelectType is set to 1 or 2.
TiltEnabled	32u	Setting for tilt compensation 0 - Disabled 1 - Enabled
EdgeHeightMin	64f	Setting for minimum edge height width (mm).
EdgeTransitionWidth	64f	Setting for edge transition width (mm).
EdgeSupportWidth	64f	Setting for edge support width (mm).
VoidMax	64f	Setting for maximum void (mm).
WidthMin	64f	Setting for minimum strip width (mm).
EdgeTransitionWidthMax	64f	Constraint for edge transition width maximum (mm).
VoidMaxLimitMax	64f	Constraint for maximum void (mm).
LinkEnabled	32u	Setting to enable/disable linking: 0 - Disable 1 - Enable
Link	32u	Measurement ID to link with
Scale	64f	Setting for scale factor to apply to measurement value
Offset	64f	Setting for offset to apply to measurement value

Element	Type	Description
SmoothingEnabled	32u	Setting to enable or disable the smoothing filter: 0 - Disable 1 - Enable
SmoothingWindow	32u	Setting for the smoothing window (frames)
HoldEnabled	32u	Setting to enable or disable the hold filter: 0 - Disable 1 - Enable
SourceOptions	String	Constraint for eligible profile sources (comma-delimited list).
SmoothingWindowMin	32u	Constraint for smoothing window minimum (frames).
SmoothingWindowMax	32u	Constraint for smoothing window maximum (frames).
LinkIds	32u	List of linkable measurements.

## Measurements / Strip Height

A Strip Height element defines settings for a profile strip height measurement.

### *Strip Height Child Elements*

Element	Type	Description
Name	String	Setting for measurement name.
Source	32s	Setting for profile source.
DecisionMin	64f	Setting for decision threshold minimum (mm).
DecisionMax	64f	Setting for decision threshold maximum (mm).
Area	Area	Element for measurement area.
Location	32s	Setting for the location of the strip: 0 - Left 1 - Right 2 - Center
BaseType	32s	Setting for the strip type: 0 - None 1 - Flat
LeftEdgeType	32s	Setting of the left edge conditions: 0 - Rising 1 - Falling 2 - Data End 3 - Void
RightEdgeType	32s	Setting of the left edge conditions: 0 - Rising 1 - Falling 2 - Data End 3 - Void
SelectType	32s	Setting for selecting a strip out of multiple strips.

Element	Type	Description
		0 - Best 1 - 0-based index, from left to right 2 - 0-based index, from right to left
SelectN	32u	Index when SelectType is set to 1 or 2.
TiltEnabled	32u	Setting for tilt compensation: 0 - Disabled 1 - Enabled
EdgeHeightMin	64f	Setting for minimum edge height width (mm).
EdgeTransitionWidth	64f	Setting for edge transition width (mm).
EdgeSupportWidth	64f	Setting for edge support width (mm).
VoidMax	64f	Setting for maximum void (mm).
WidthMin	64f	Setting for minimum strip width (mm).
EdgeTransitionWidthMax	64f	Constraint for edge transition width maximum (mm).
VoidMaxLimitMax	64f	Constraint for maximum void (mm).
LinkEnabled	32u	Setting to enable/disable linking: 0 - Disable 1 - Enable
Link	32u	Measurement ID to link with
Scale	64f	Setting for scale factor to apply to measurement value
Offset	64f	Setting for offset to apply to measurement value
SmoothingEnabled	32u	Setting to enable or disable the smoothing filter: 0 - Disable 1 - Enable
SmoothingWindow	32u	Setting for the smoothing window (frames)
HoldEnabled	32u	Setting to enable or disable the hold filter: 0 - Disable 1 - Enable
SourceOptions	String	Constraint for eligible profile sources (comma-delimited list).
SmoothingWindowMin	32u	Constraint for smoothing window minimum (frames).
SmoothingWindowMax	32u	Constraint for smoothing window maximum (frames).
LinkIds	32u	List of linkable measurements.

## Measurements / Script

A Script element defines settings for a script measurement.

### Script Child Elements

Element	Type	Description
Name	String	Setting for measurement name.
Code	String	Script code.

## Part

The Part element contains settings that affect part measurements. Simple child elements in Part are defined below:

### *Part Child Elements*

Element	Type	Description
MeasurementOptions	String	Constraint for available measurement types - comma delimited list (e.g., "Area, Volume").

The Part element also contains two significant sub-elements: Detection and Measurements. The Detection element defines the part detection behavior, while the Measurements element contains one sub-element for each requested part measurement.

The id attribute associated with each measurement defines an identifier that must be unique among all measurements in the configuration file, for example:

```
<Area id="1001">
```

Most part measurement elements contain one or more region (2D), region (3D) or circle region.

The Id attribute of the Script tool is a comma-delimited list, for multiple output support.

## Detection

A Detection element defines settings for part detection.

### *Detection Child Elements*

Element	Type	Description
HeightThreshold	64f	Setting for height threshold (mm).
GapThreshold	64f	Setting for gap threshold (mm).
AreaThreshold	64f	Setting for area threshold (mm <sup>2</sup> ).
LengthMax	64f	Setting for maximum length of a part (mm).
HeightThresholdDirection	32u	Setting for whether data is included for above or below the threshold: 0 – Above 1 – Below
FrameOfReference	32u	Setting for frame of reference: 0 – Sensor 1 – Part  This setting applies to all part measurement except for bounding box, which is always relative to the sensor's FOV.
HeightThresholdMin	64f	Constraint for height threshold minimum (mm).
HeightThresholdMax	64f	Constraint for height threshold maximum (mm).
GapThresholdMin	64f	Constraint for gap threshold minimum (mm).
GapThresholdMax	64f	Constraint for gap threshold maximum (mm).

Element	Type	Description
AreaThresholdMin	64f	Constraint for area threshold minimum (mm2).
AreaThresholdMax	64f	Constraint for area threshold maximum (mm2).
LengthMaxLimitMin	64f	Constraint for lengthMax minimum (mm).
LengthMaxLimitMax	64f	Constraint for lengthMax maximum (mm).

## PartRegion

A PartRegion element defines a rectangular area of interest on the X-Y plane.

### *PartRegion Child Elements*

Element	Type	Description
X	64f	Setting for area X position (mm).
Y	64f	Setting for area Z position (mm).
Width	64f	Setting for region width (mm).
Height	64f	Setting for region height (mm).

## PartRegion3D

A Part Region 3D element defines a rectangular area of interest in 3D.

### *Part Region 3D Child Elements*

Element	Type	Description
X	64f	Setting for volume x position (mm).
Y	64f	Setting for volume y position (mm).
Z	64f	Setting for volume z position (mm).
Width	64f	Setting for volume width (mm).
Length	64f	Setting for volume length (mm).
Height	64f	Setting for volume height (mm).

## SurfaceCircleRegion

A Surface Circle Region element defines a circular surface area of interest.

### *Surface Circle Region Child Elements*

Element	Type	Description
X	64f	Setting for circle x position (mm).
Y	64f	Setting for circle y position (mm).
Radius	64f	Setting for circle radius (mm).

## SurfaceFeature3d

A Feature element defines the settings for detecting a feature within an area of interest.

### Feature Child Elements

Element	Type	Description
Type	32s	Setting to determine how the feature is detected within the area: 0 - Centroid 2d 1 - Centroid 3d 2 - X Min 3 - X Max 4 - Y Min 5 - Y Max 6 - Z Min 7 - Z Max
RegionEnabled	32u	Setting to enable/disable region: 0 - Disable 1 - Enable
Region	PartRegion3d	Element for feature detection volume.

### Measurements / PartArea

A PartArea element defines settings for an area measurement.

### Part Area Child Elements

Element	Type	Description
Name	String	Setting for measurement name.
DecisionMin	64f	Setting for decision threshold minimum (mm2).
DecisionMax	64f	Setting for decision threshold maximum (mm2).
RegionEnabled	32u	Setting to enable/disable region: 0 - Disable 1 - Enable
Region	PartRegion3d	Measurement region
LinkEnabled	32u	Setting to enable/disable linking: 0 - Disable 1 - Enable
Link	32u	Measurement ID to link with
Scale	64f	Setting for scale factor to apply to measurement value
Offset	64f	Setting for offset to apply to measurement value
SmoothingEnabled	32u	Setting to enable or disable the smoothing filter: 0 - Disable 1 - Enable
SmoothingWindow	32u	Setting for the smoothing window (frames)
HoldEnabled	32u	Setting to enable or disable the hold filter: 0 - Disable

Element	Type	Description
		1 - Enable
SmoothingWindowMin	32u	Constraint for smoothing window minimum (frames).
SmoothingWindowMax	32u	Constraint for smoothing window maximum (frames).
LinkIds	32u	List of linkable measurements.

## Measurements / PartVolume

A PartVolume element defines settings for a volume measurement.

### Part Volume Child Elements

Element	Type	Description
Name	String	Setting for measurement name.
DecisionMin	64f	Setting for decision threshold minimum (mm3).
DecisionMax	64f	Setting for decision threshold maximum (mm3).
RegionEnabled	32u	Setting to enable/disable region: 0 - Disable 1 - Enable
Region	PartRegion3 d	Measurement region
LinkEnabled	32u	Setting to enable/disable linking: 0 - Disable 1 - Enable
Link	32u	Measurement ID to link with
Scale	64f	Setting for scale factor to apply to measurement value
Offset	64f	Setting for offset to apply to measurement value
SmoothingEnabled	32u	Setting to enable or disable the smoothing filter: 0 - Disable 1 - Enable
SmoothingWindow	32u	Setting for the smoothing window (frames)
HoldEnabled	32u	Setting to enable or disable the hold filter: 0 - Disable 1 - Enable
SmoothingWindowMin	32u	Constraint for smoothing window minimum (frames).
SmoothingWindowMax	32u	Constraint for smoothing window maximum (frames).
LinkIds	32u	List of linkable measurements.

## Measurements / PartHeight

A PartHeight element defines settings for a height measurement.

### Part Height Child Elements

Element	Type	Description
Name	String	Setting for measurement name.
DecisionMin	64f	Setting for decision threshold minimum (mm).
DecisionMax	64f	Setting for decision threshold maximum (mm).
Type	32s	Setting for measurement type: 0 - Minimum 1 - Maximum 2 - 2D Centroid 3 - 3D Centroid 4 - Average 5 - Median
RegionEnabled	32u	Setting to enable/disable region: 0 - Disable 1 - Enable
Region	PartRegion3 d	Measurement region
LinkEnabled	32u	Setting to enable/disable linking: 0 - Disable 1 - Enable
Link	32u	Measurement ID to link with
Scale	64f	Setting for scale factor to apply to measurement value
Offset	64f	Setting for offset to apply to measurement value
SmoothingEnabled	32u	Setting to enable or disable the smoothing filter: 0 - Disable 1 - Enable
SmoothingWindow	32u	Setting for the smoothing window (frames)
HoldEnabled	32u	Setting to enable or disable the hold filter: 0 - Disable 1 - Enable
SmoothingWindowMin	32u	Constraint for smoothing window minimum (frames).
SmoothingWindowMax	32u	Constraint for smoothing window maximum (frames).
LinkIds	32u	List of linkable measurements.

## Measurements / PartEllipseMajor

A PartEllipseMajor element defines settings for an ellipse major measurement.

### Part Ellipse Major Child Elements

Element	Type	Description
Name	String	Setting for measurement name.
DecisionMin	64f	Setting for decision threshold minimum (mm).

<b>Element</b>	<b>Type</b>	<b>Description</b>
DecisionMax	64f	Setting for decision threshold maximum (mm).
RegionEnabled	32u	Setting to enable/disable region: 0 - Disable 1 - Enable
Region	PartRegion3 d	Measurement region
LinkEnabled	32u	Setting to enable/disable linking: 0 - Disable 1 - Enable
Link	32u	Measurement ID to link with
Scale	64f	Setting for scale factor to apply to measurement value
Offset	64f	Setting for offset to apply to measurement value
SmoothingEnabled	32u	Setting to enable or disable the smoothing filter: 0 - Disable 1 - Enable
SmoothingWindow	32u	Setting for the smoothing window (frames)
HoldEnabled	32u	Setting to enable or disable the hold filter: 0 - Disable 1 - Enable
SmoothingWindowMin	32u	Constraint for smoothing window minimum (frames).
SmoothingWindowMax	32u	Constraint for smoothing window maximum (frames).
LinkIds	32u	List of linkable measurements.

## Measurements / PartEllipseMinor

A PartEllipseMinor element defines settings for an ellipse minor measurement.

### *Part Ellipse Minor Child Elements*

<b>Element</b>	<b>Type</b>	<b>Description</b>
Name	String	Setting for measurement name.
DecisionMin	64f	Setting for decision threshold minimum (mm).
DecisionMax	64f	Setting for decision threshold maximum (mm).
RegionEnabled	32u	Setting to enable/disable region: 0 - Disable 1 - Enable
Region	PartRegion3 d	Measurement region
LinkEnabled	32u	Setting to enable/disable linking: 0 - Disable 1 - Enable

<b>Element</b>	<b>Type</b>	<b>Description</b>
Link	32u	Measurement ID to link with
Scale	64f	Setting for scale factor to apply to measurement value
Offset	64f	Setting for offset to apply to measurement value
SmoothingEnabled	32u	Setting to enable or disable the smoothing filter: 0 - Disable 1 - Enable
SmoothingWindow	32u	Setting for the smoothing window (frames)
HoldEnabled	32u	Setting to enable or disable the hold filter: 0 - Disable 1 - Enable
SmoothingWindowMin	32u	Constraint for smoothing window minimum (frames).
SmoothingWindowMax	32u	Constraint for smoothing window maximum (frames).
LinkIds	32u	List of linkable measurements.

## Measurements / PartEllipseAngle

A PartEllipseAngle element defines settings for an ellipse angle measurement.

### *Part Ellipse Angle Child Elements*

<b>Element</b>	<b>Type</b>	<b>Description</b>
Name	String	Setting for measurement name.
DecisionMin	64f	Setting for decision threshold minimum (degrees).
DecisionMax	64f	Setting for decision threshold maximum (degrees).
RegionEnabled	32u	Setting to enable/disable region: 0 - Disable 1 - Enable
Region	PartRegion3 d	Measurement region
LinkEnabled	32u	Setting to enable/disable linking: 0 - Disable 1 - Enable
Link	32u	Measurement ID to link with
Scale	64f	Setting for scale factor to apply to measurement value
Offset	64f	Setting for offset to apply to measurement value
SmoothingEnabled	32u	Setting to enable or disable the smoothing filter: 0 - Disable 1 - Enable
SmoothingWindow	32u	Setting for the smoothing window (frames)
HoldEnabled	32u	Setting to enable or disable the hold filter: 0 - Disable

Element	Type	Description
		1 - Enable
SmoothingWindowMin	32u	Constraint for smoothing window minimum (frames).
SmoothingWindowMax	32u	Constraint for smoothing window maximum (frames).
LinkIds	32u	List of linkable measurements.

## Measurements / PartEllipseRatio

A PartEllipseRatio element defines settings for an ellipse ratio measurement.

### Part Ellipse Ratio Child Elements

Element	Type	Description
Name	String	Setting for measurement name.
DecisionMin	64f	Setting for decision threshold minimum.
DecisionMax	64f	Setting for decision threshold maximum.
RegionEnabled	32u	Setting to enable/disable region: 0 - Disable 1 - Enable
Region	PartRegion3 d	Measurement region
LinkEnabled	32u	Setting to enable/disable linking: 0 - Disable 1 - Enable
Link	32u	Measurement ID to link with
Scale	64f	Setting for scale factor to apply to measurement value
Offset	64f	Setting for offset to apply to measurement value
SmoothingEnabled	32u	Setting to enable or disable the smoothing filter: 0 - Disable 1 - Enable
SmoothingWindow	32u	Setting for the smoothing window (frames)
HoldEnabled	32u	Setting to enable or disable the hold filter: 0 - Disable 1 - Enable
SmoothingWindowMin	32u	Constraint for smoothing window minimum (frames).
SmoothingWindowMax	32u	Constraint for smoothing window maximum (frames).
LinkIds	32u	List of linkable measurements.

## Measurements / PartBoundingBox

A PartBoundingBox element defines settings for a bounding box X measurement.

### *Part Bounding Box X Child Elements*

<b>Element</b>	<b>Type</b>	<b>Description</b>
Name	String	Setting for measurement name.
DecisionMin	64f	Setting for decision threshold minimum (mm).
DecisionMax	64f	Setting for decision threshold maximum (mm).
RotationEnable	32u	Setting to enable or disable bounding box rotation: 0 - Vertical bounding box 1 - Rotated bounding box
RegionEnabled	32u	Setting to enable/disable region: 0 - Disable 1 - Enable
Region	PartRegion3 d	Measurement region
LinkEnabled	32u	Setting to enable/disable linking: 0 - Disable 1 - Enable
Link	32u	Measurement ID to link with
Scale	64f	Setting for scale factor to apply to measurement value
Offset	64f	Setting for offset to apply to measurement value
SmoothingEnabled	32u	Setting to enable or disable the smoothing filter: 0 - Disable 1 - Enable
SmoothingWindow	32u	Setting for the smoothing window (frames)
HoldEnabled	32u	Setting to enable or disable the hold filter: 0 - Disable 1 - Enable
SmoothingWindowMin	32u	Constraint for smoothing window minimum (frames).
SmoothingWindowMax	32u	Constraint for smoothing window maximum (frames).
LinkIds	32u	List of linkable measurements.

## **Measurements / PartBoundingBoxY**

A PartBoundingBoxY element defines settings for a bounding box Y measurement.

### *Part Bounding Box Y Child Elements*

<b>Element</b>	<b>Type</b>	<b>Description</b>
Name	String	Setting for measurement name.
DecisionMin	64f	Setting for decision threshold minimum (mm).
DecisionMax	64f	Setting for decision threshold maximum (mm).
RotationEnable	32u	Setting to enable or disable bounding box rotation: 0 - Vertical bounding box 1 - Rotated bounding box.

<b>Element</b>	<b>Type</b>	<b>Description</b>
RegionEnabled	32u	Setting to enable/disable region: 0 – Disable 1 – Enable
Region	PartRegion3 d	Measurement region
LinkEnabled	32u	Setting to enable/disable linking: 0 – Disable 1 – Enable
Link	32u	Measurement ID to link with
Scale	64f	Setting for scale factor to apply to measurement value
Offset	64f	Setting for offset to apply to measurement value
SmoothingEnabled	32u	Setting to enable or disable the smoothing filter: 0 – Disable 1 – Enable
SmoothingWindow	32u	Setting for the smoothing window (frames)
HoldEnabled	32u	Setting to enable or disable the hold filter: 0 – Disable 1 – Enable
SmoothingWindowMin	32u	Constraint for smoothing window minimum (frames).
SmoothingWindowMax	32u	Constraint for smoothing window maximum (frames).
LinkIds	32u	List of linkable measurements.

## Measurements / PartBoundingBoxWidth

A PartBoundingBoxWidth element defines settings for a bounding box width measurement.

### *Part Bounding Box Width Child Elements*

<b>Element</b>	<b>Type</b>	<b>Description</b>
Name	String	Setting for measurement name.
DecisionMin	64f	Setting for decision threshold minimum (mm).
DecisionMax	64f	Setting for decision threshold maximum (mm).
RotationEnable	32u	Setting to enable or disable bounding box rotation: 0 – Vertical bounding box 1 – Rotated bounding box
RegionEnabled	32u	Setting to enable/disable region: 0 – Disable 1 – Enable
Region	PartRegion3 d	Measurement region
LinkEnabled	32u	Setting to enable/disable linking 0 – Disable

Element	Type	Description
		1 - Enable
Link	32u	Measurement ID to link with
Scale	64f	Setting for scale factor to apply to measurement value
Offset	64f	Setting for offset to apply to measurement value
SmoothingEnabled	32u	Setting to enable or disable the smoothing filter: 0 - Disable 1 - Enable
SmoothingWindow	32u	Setting for the smoothing window (frames)
HoldEnabled	32u	Setting to enable or disable the hold filter: 0 - Disable 1 - Enable
SmoothingWindowMin	32u	Constraint for smoothing window minimum (frames).
SmoothingWindowMax	32u	Constraint for smoothing window maximum (frames).
LinkIds	32u	List of linkable measurements.

## Measurements / PartBoundingBoxLength

A PartBoundingBoxLength element defines settings for a bounding box length measurement.

### Part Bounding Box Length Child Elements

Element	Type	Description
Name	String	Setting for measurement name.
DecisionMin	64f	Setting for decision threshold minimum (mm).
DecisionMax	64f	Setting for decision threshold maximum (mm).
RotationEnable	32u	Setting to enable or disable bounding box rotation: 0 - Vertical bounding box 1 - Rotated bounding box
RegionEnabled	32u	Setting to enable/disable region: 0 - Disable 1 - Enable
Region	PartRegion3 d	Measurement region
LinkEnabled	32u	Setting to enable/disable linking: 0 - Disable 1 - Enable
Link	32u	Measurement ID to link with
Scale	64f	Setting for scale factor to apply to measurement value
Offset	64f	Setting for offset to apply to measurement value
SmoothingEnabled	32u	Setting to enable or disable the smoothing filter: 0 - Disable

Element	Type	Description
		1 - Enable
SmoothingWindow	32u	Setting for the smoothing window (frames)
HoldEnabled	32u	Setting to enable or disable the hold filter: 0 - Disable 1 - Enable
SmoothingWindowMin	32u	Constraint for smoothing window minimum (frames).
SmoothingWindowMax	32u	Constraint for smoothing window maximum (frames).
LinkIds	32u	List of linkable measurements.

## Measurements / PartBoundingBoxAngle

A PartBoundingBoxAngle element defines settings for a bounding box angle measurement.

### Part Bounding Box Angle Child Elements

Element	Type	Description
Name	String	Setting for measurement name.
DecisionMin	64f	Setting for decision threshold minimum (mm).
DecisionMax	64f	Setting for decision threshold maximum (mm).
RotationEnable	32u	Setting to enable or disable bounding box rotation: 0 - Vertical bounding box 1 - Rotated bounding box
RegionEnabled	32u	Setting to enable/disable region: 0 - Disable 1 - Enable
Region	PartRegion3 d	Measurement region
LinkEnabled	32u	Setting to enable/disable linking 0 - Disable 1 - Enable
Link	32u	Measurement ID to link with
Scale	64f	Setting for scale factor to apply to measurement value
Offset	64f	Setting for offset to apply to measurement value
SmoothingEnabled	32u	Setting to enable or disable the smoothing filter: 0 - Disable 1 - Enable
SmoothingWindow	32u	Setting for the smoothing window (frames)
HoldEnabled	32u	Setting to enable or disable the hold filter: 0 - Disable 1 - Enable
SmoothingWindowMin	32u	Constraint for smoothing window minimum (frames).
SmoothingWindowMax	32u	Constraint for smoothing window maximum (frames).
LinkIds	32u	List of linkable measurements.

## Measurements / PartHoleX

A PartHoleX element defines settings for a Hole X measurement.

### *Part Hole X Child Elements*

<b>Element</b>	<b>Type</b>	<b>Description</b>
Name	String	Setting for measurement name.
DecisionMin	64f	Setting for decision threshold minimum (mm).
DecisionMax	64f	Setting for decision threshold maximum (mm).
NominalRadius	64f	Setting for the nominal radius (mm)
RadiusTolerance	64f	Setting for the radius tolerance (mm)
PartialDetectionEnabled	32u	Setting to enable/disable partial detection: 0 - Disable 1 - Enable
RegionEnabled	32u	Setting to enable/disable region: 0 - Disable 1 - Enable
Region	PartRegion3 d	Measurement region
AutoRefRegionEnabled	32u	Setting to enable/disable reference region: 0 - Disable 1 - Enable
RefRegions	(Collection)	Reference regions, contains 1 or 2 RefRegion elements
RefRegions/RefRegion	PartRegion	Reference region
AutoTiltCorrectionEnabled	32u	Setting to enable/disable tilt correction: 0 - Disable 1 - Enable
TiltXAngle	64f	Setting for manual tilt correction angle X
TiltYAngle	64f	Setting for manual tilt correction angle Y
LinkEnabled	32u	Setting to enable/disable linking: 0 - Disable 1 - Enable
Link	32u	Measurement ID to link with
Scale	64f	Setting for scale factor to apply to measurement value
Offset	64f	Setting for offset to apply to measurement value
SmoothingEnabled	32u	Setting to enable or disable the smoothing filter: 0 - Disable 1 - Enable
SmoothingWindow	32u	Setting for the smoothing window (frames)
HoldEnabled	32u	Setting to enable or disable the hold filter: 0 - Disable

Element	Type	Description
		1 - Enable
SmoothingWindowMin	32u	Constraint for smoothing window minimum (frames).
SmoothingWindowMax	32u	Constraint for smoothing window maximum (frames).
LinkIds	32u	List of linkable measurements.

## Measurements / PartHoleY

A PartHoleY element defines settings for a Hole Y measurement.

### Part Hole Y Child Elements

Element	Type	Description
Name	String	Setting for measurement name.
DecisionMin	64f	Setting for decision threshold minimum (mm).
DecisionMax	64f	Setting for decision threshold maximum (mm).
NominalRadius	64f	Setting for the nominal radius (mm)
RadiusTolerance	64f	Setting for the radius tolerance (mm)
PartialDetectionEnabled	32u	Setting to enable/disable partial detection: 0 - Disable 1 - Enable
RegionEnabled	32u	Setting to enable/disable region: 0 - Disable 1 - Enable
Region	PartRegion3 d	Measurement region
AutoRefRegionEnabled	32u	Setting to enable/disable reference region: 0 - Disable 1 - Enable
RefRegions	(Collection)	Reference regions, contains 1 or 2 RefRegion elements
RefRegions/RefRegion	PartRegion	Reference region
AutoTiltCorrectionEnabled	32u	Setting to enable/disable tilt correction: 0 - Disable 1 - Enable
TiltXAngle	64f	Setting for manual tilt correction angle X
TiltYAngle	64f	Setting for manual tilt correction angle Y
LinkEnabled	32u	Setting to enable/disable linking: 0 - Disable 1 - Enable
Link	32u	Measurement ID to link with
Scale	64f	Setting for scale factor to apply to measurement value
Offset	64f	Setting for offset to apply to measurement value

Element	Type	Description
SmoothingEnabled	32u	Setting to enable or disable the smoothing filter: 0 – Disable 1 – Enable
SmoothingWindow	32u	Setting for the smoothing window (frames)
HoldEnabled	32u	Setting to enable or disable the hold filter: 0 – Disable 1 – Enable
SmoothingWindowMin	32u	Constraint for smoothing window minimum (frames).
SmoothingWindowMax	32u	Constraint for smoothing window maximum (frames).
LinkIds	32u	List of linkable measurements.

## Measurements / PartHoleZ

A PartHoleZ element defines settings for a Hole Z measurement.

### *Part Hole Z Child Elements*

Element	Type	Description
Name	String	Setting for measurement name.
DecisionMin	64f	Setting for decision threshold minimum (mm).
DecisionMax	64f	Setting for decision threshold maximum (mm).
NominalRadius	64f	Setting for the nominal radius (mm)
RadiusTolerance	64f	Setting for the radius tolerance (mm)
PartialDetectionEnabled	32u	Setting to enable/disable partial detection: 0 – Disable 1 – Enable
RegionEnabled	32u	Setting to enable/disable region: 0 – Disable 1 – Enable
Region	PartRegion3 d	Measurement region
AutoRefRegionEnabled	32u	Setting to enable/disable reference region: 0 – Disable 1 – Enable
RefRegions	(Collection)	Reference regions, contains 1 or 2 RefRegion elements
RefRegions/RefRegion	PartRegion	Reference region
AutoTiltCorrectionEnabled	32u	Setting to enable/disable tilt correction: 0 – Disable 1 – Enable
TiltXAngle	64f	Setting for manual tilt correction angle X
TiltYAngle	64f	Setting for manual tilt correction angle Y

Element	Type	Description
LinkEnabled	32u	Setting to enable/disable linking: 0 – Disable 1 – Enable
Link	32u	Measurement ID to link with
Scale	64f	Setting for scale factor to apply to measurement value
Offset	64f	Setting for offset to apply to measurement value
SmoothingEnabled	32u	Setting to enable or disable the smoothing filter: 0 – Disable 1 – Enable
SmoothingWindow	32u	Setting for the smoothing window (frames)
HoldEnabled	32u	Setting to enable or disable the hold filter: 0 – Disable 1 – Enable
SmoothingWindowMin	32u	Constraint for smoothing window minimum (frames).
SmoothingWindowMax	32u	Constraint for smoothing window maximum (frames).
LinkIds	32u	List of linkable measurements.

## Measurements / PartHoleRadius

A PartHoleRadius element defines settings for a Hole Radius measurement.

### Part Hole Radius Child Elements

Element	Type	Description
Name	String	Setting for measurement name.
DecisionMin	64f	Setting for decision threshold minimum (mm).
DecisionMax	64f	Setting for decision threshold maximum (mm).
NominalRadius	64f	Setting for the nominal radius (mm)
RadiusTolerance	64f	Setting for the radius tolerance (mm)
PartialDetectionEnabled	32u	Setting to enable/disable partial detection: 0 – Disable 1 – Enable
RegionEnabled	32u	Setting to enable/disable region: 0 – Disable 1 – Enable
Region	PartRegion3 d	Measurement region
AutoRefRegionEnabled	32u	Setting to enable/disable reference region: 0 – Disable 1 – Enable
RefRegions	(Collection)	Reference regions, contains 1 or 2 RefRegion elements

<b>Element</b>	<b>Type</b>	<b>Description</b>
RefRegions/RefRegion	PartRegion	Reference region
AutoTiltCorrectionEnabled	32u	Setting to enable/disable tilt correction: 0 – Disable 1 – Enable
TiltXAngle	64f	Setting for manual tilt correction angle X
TiltYAngle	64f	Setting for manual tilt correction angle Y
LinkEnabled	32u	Setting to enable/disable linking: 0 – Disable 1 – Enable
Link	32u	Measurement ID to link with
Scale	64f	Setting for scale factor to apply to measurement value
Offset	64f	Setting for offset to apply to measurement value
SmoothingEnabled	32u	Setting to enable or disable the smoothing filter: 0 – Disable 1 – Enable
SmoothingWindow	32u	Setting for the smoothing window (frames)
HoldEnabled	32u	Setting to enable or disable the hold filter: 0 – Disable 1 – Enable
SmoothingWindowMin	32u	Constraint for smoothing window minimum (frames).
SmoothingWindowMax	32u	Constraint for smoothing window maximum (frames).
LinkIds	32u	List of linkable measurements.

## Measurements / PartOpeningX

A Part Opening X element defines settings for a Part Opening X measurement.

### *Part Opening X Child Elements*

<b>Element</b>	<b>Type</b>	<b>Description</b>
Name	String	Setting for measurement name.
DecisionMin	64f	Setting for decision threshold minimum (mm).
DecisionMax	64f	Setting for decision threshold maximum (mm).
NominalWidth	64f	Setting for the nominal width (mm)
WidthTolerance	64f	Setting for the width tolerance (mm)
NominalLength	64f	Setting for the nominal length (mm)
LengthTolerance	64f	Setting for the length tolerance (mm)
NominalAngle	64f	Setting for the nominal angle (degrees)
AngleTolerance	64f	Setting for the length tolerance (degrees)
NominalRadius	64f	Setting for nominal radius(mm)

Element	Type	Description
PartialDetectionEnabled	32u	Setting to enable/disable partial detection: 0 – Disable 1 – Enable
RegionEnabled	32u	Setting to enable/disable region: 0 – Disable 1 – Enable
Region	PartRegion3 d	Measurement region
RefRegions	(Collection)	Reference regions, contains 1 or 2 RefRegion elements
AutoRefRegionEnabled	32u	Setting to enable/disable reference region: 0 – Disable 1 – Enable
RefRegions/RefRegion	PartRegion	Reference region
AutoTiltCorrectionEnabled	32u	Setting to enable/disable tilt correction: 0 – Disable 1 – Enable
TiltXAngle	64f	Setting for manual tilt correction angle X
TiltYAngle	64f	Setting for manual tilt correction angle Y
Type	32u	Opening type: 0 – Slot 1 – Rectangle
LinkEnabled	32u	Setting to enable/disable linking: 0 – Disable 1 – Enable
Link	32u	Measurement ID to link with
Scale	64f	Setting for scale factor to apply to measurement value
Offset	64f	Setting for offset to apply to measurement value
SmoothingEnabled	32u	Setting to enable or disable the smoothing filter: 0 – Disable 1 – Enable
SmoothingWindow	32u	Setting for the smoothing window (frames)
HoldEnabled	32u	Setting to enable or disable the hold filter: 0 – Disable 1 – Enable
SmoothingWindowMin	32u	Constraint for smoothing window minimum (frames).
SmoothingWindowMax	32u	Constraint for smoothing window maximum (frames).
LinkIds	32u	List of linkable measurements.

## Measurements / PartOpeningY

A Part Opening Y element defines settings for a Part Opening Y measurement.

*Part Opening Y Child Elements*

<b>Element</b>	<b>Type</b>	<b>Description</b>
Name	String	Setting for measurement name.
DecisionMin	64f	Setting for decision threshold minimum (mm).
DecisionMax	64f	Setting for decision threshold maximum (mm).
NominalWidth	64f	Setting for the nominal width (mm)
WidthTolerance	64f	Setting for the width tolerance (mm)
NominalLength	64f	Setting for the nominal length (mm)
LengthTolerance	64f	Setting for the length tolerance (mm)
NominalAngle	64f	Setting for the nominal angle (degrees)
AngleTolerance	64f	Setting for the length tolerance (degrees)
NominalRadius	64f	Setting for nominal radius(mm)
PartialDetectionEnabled	32u	Setting to enable/disable partial detection: 0 - Disable 1 - Enable
RegionEnabled	32u	Setting to enable/disable region: 0 - Disable 1 - Enable
Region	PartRegion3 d	Measurement region
RefRegions	(Collection)	Reference regions, contains 1 or 2 RefRegion elements
AutoRefRegionEnabled	32u	Setting to enable/disable reference region: 0 - Disable 1 - Enable
RefRegions/RefRegion	PartRegion	Reference region
AutoTiltCorrectionEnabled	32u	Setting to enable/disable tilt correction 0 - Disable 1 - Enable
TiltXAngle	64f	Setting for manual tilt correction angle X
TiltYAngle	64f	Setting for manual tilt correction angle Y
Type	32u	Opening type: 0 - Slot 1 - Rectangle
LinkEnabled	32u	Setting to enable/disable linking: 0 - Disable 1 - Enable
Link	32u	Measurement ID to link with
Scale	64f	Setting for scale factor to apply to measurement value

<b>Element</b>	<b>Type</b>	<b>Description</b>
Offset	64f	Setting for offset to apply to measurement value
SmoothingEnabled	32u	Setting to enable or disable the smoothing filter: 0 – Disable 1 – Enable
SmoothingWindow	32u	Setting for the smoothing window (frames)
HoldEnabled	32u	Setting to enable or disable the hold filter: 0 – Disable 1 – Enable
SmoothingWindowMin	32u	Constraint for smoothing window minimum (frames).
SmoothingWindowMax	32u	Constraint for smoothing window maximum (frames).
LinkIds	32u	List of linkable measurements.

## Measurements / PartOpeningZ

A Part Opening Z element defines settings for a Part Opening Z measurement.

### *Part Opening Z Child Elements*

<b>Element</b>	<b>Type</b>	<b>Description</b>
Name	String	Setting for measurement name.
DecisionMin	64f	Setting for decision threshold minimum (mm).
DecisionMax	64f	Setting for decision threshold maximum (mm).
NominalWidth	64f	Setting for the nominal width (mm)
WidthTolerance	64f	Setting for the width tolerance (mm)
NominalLength	64f	Setting for the nominal length (mm)
LengthTolerance	64f	Setting for the length tolerance (mm)
NominalAngle	64f	Setting for the nominal angle (degrees)
AngleTolerance	64f	Setting for the length tolerance (degrees)
NominalRadius	64f	Setting for nominal radius(mm)
PartialDetectionEnabled	32u	Setting to enable/disable partial detection: 0 – Disable 1 – Enable
RegionEnabled	32u	Setting to enable/disable region: 0 – Disable 1 – Enable
Region	PartRegion3 d	Measurement region
RefRegions	(Collection)	Reference regions, contains 1 or 2 RefRegion elements
AutoRefRegionEnabled	32u	Setting to enable/disable reference region: 0 – Disable 1 – Enable

<b>Element</b>	<b>Type</b>	<b>Description</b>
RefRegions/RefRegion	PartRegion	Reference region
AutoTiltCorrectionEnabled	32u	Setting to enable/disable tilt correction: 0 – Disable 1 – Enable
TiltXAngle	64f	Setting for manual tilt correction angle X
TiltYAngle	64f	Setting for manual tilt correction angle Y
Type	32u	Opening type: 0 – Slot 1 – Rectangle
LinkEnabled	32u	Setting to enable/disable linking: 0 – Disable 1 – Enable
Link	32u	Measurement ID to link with
Scale	64f	Setting for scale factor to apply to measurement value
Offset	64f	Setting for offset to apply to measurement value
SmoothingEnabled	32u	Setting to enable or disable the smoothing filter: 0 – Disable 1 – Enable
SmoothingWindow	32u	Setting for the smoothing window (frames)
HoldEnabled	32u	Setting to enable or disable the hold filter: 0 – Disable 1 – Enable
SmoothingWindowMin	32u	Constraint for smoothing window minimum (frames).
SmoothingWindowMax	32u	Constraint for smoothing window maximum (frames).
LinkIds	32u	List of linkable measurements.

## Measurements / PartOpeningLength

A Part Opening Length element defines settings for a Part Opening Length measurement.

### *Part Opening Length Child Elements*

<b>Element</b>	<b>Type</b>	<b>Description</b>
Name	String	Setting for measurement name.
DecisionMin	64f	Setting for decision threshold minimum (mm).
DecisionMax	64f	Setting for decision threshold maximum (mm).
NominalWidth	64f	Setting for the nominal width (mm)
WidthTolerance	64f	Setting for the width tolerance (mm)
NominalLength	64f	Setting for the nominal length (mm)
LengthTolerance	64f	Setting for the length tolerance (mm)

<b>Element</b>	<b>Type</b>	<b>Description</b>
NominalAngle	64f	Setting for the nominal angle (degrees)
AngleTolerance	64f	Setting for the length tolerance (degrees)
NominalRadius	64f	Setting for nominal radius(mm)
PartialDetectionEnabled	32u	Setting to enable/disable partial detection: 0 - Disable 1 - Enable
RegionEnabled	32u	Setting to enable/disable region: 0 - Disable 1 - Enable
Region	PartRegion3 d	Measurement region
RefRegions	(Collection)	Reference regions, contains 1 or 2 RefRegion elements
AutoRefRegionEnabled	32u	Setting to enable/disable reference region: 0 - Disable 1 - Enable
RefRegions/RefRegion	PartRegion	Reference region
AutoTiltCorrectionEnabled	32u	Setting to enable/disable tilt correction: 0 - Disable 1 - Enable
TiltXAngle	64f	Setting for manual tilt correction angle X
TiltYAngle	64f	Setting for manual tilt correction angle Y
Type	32u	Opening type: 0 - Slot 1 - Rectangle
LinkEnabled	32u	Setting to enable/disable linking: 0 - Disable 1 - Enable
Link	32u	Measurement ID to link with
Scale	64f	Setting for scale factor to apply to measurement value
Offset	64f	Setting for offset to apply to measurement value
SmoothingEnabled	32u	Setting to enable or disable the smoothing filter: 0 - Disable 1 - Enable
SmoothingWindow	32u	Setting for the smoothing window (frames)
HoldEnabled	32u	Setting to enable or disable the hold filter: 0 - Disable 1 - Enable
SmoothingWindowMin	32u	Constraint for smoothing window minimum (frames).
SmoothingWindowMax	32u	Constraint for smoothing window maximum (frames).
LinkIds	32u	List of linkable measurements.

## Measurements / PartOpeningAngle

A Part Opening Angle element defines settings for a Part Opening Angle measurement.

### *Part Opening Angle Child Elements*

<b>Element</b>	<b>Type</b>	<b>Description</b>
Name	String	Setting for measurement name.
DecisionMin	64f	Setting for decision threshold minimum (mm).
DecisionMax	64f	Setting for decision threshold maximum (mm).
NominalWidth	64f	Setting for the nominal width (mm)
WidthTolerance	64f	Setting for the width tolerance (mm)
NominalLength	64f	Setting for the nominal length (mm)
LengthTolerance	64f	Setting for the length tolerance (mm)
NominalAngle	64f	Setting for the nominal angle (degrees)
AngleTolerance	64f	Setting for the length tolerance (degrees)
NominalRadius	64f	Setting for nominal radius(mm)
PartialDetectionEnabled	32u	Setting to enable/disable partial detection: 0 - Disable 1 - Enable
RegionEnabled	32u	Setting to enable/disable region: 0 - Disable 1 - Enable
Region	PartRegion3 d	Measurement region
RefRegions	(Collection)	Reference regions, contains 1 or 2 RefRegion elements
AutoRefRegionEnabled	32u	Setting to enable/disable reference region: 0 - Disable 1 - Enable
RefRegions/RefRegion	PartRegion	Reference region
AutoTiltCorrectionEnabled	32u	Setting to enable/disable tilt correction: 0 - Disable 1 - Enable
TiltXAngle	64f	Setting for manual tilt correction angle X
TiltYAngle	64f	Setting for manual tilt correction angle Y
Type	32u	Opening type: 0 - Slot 1 - Rectangle
LinkEnabled	32u	Setting to enable/disable linking: 0 - Disable 1 - Enable
Link	32u	Measurement ID to link with

Element	Type	Description
Scale	64f	Setting for scale factor to apply to measurement value
Offset	64f	Setting for offset to apply to measurement value
SmoothingEnabled	32u	Setting to enable or disable the smoothing filter: 0 - Disable 1 - Enable
SmoothingWindow	32u	Setting for the smoothing window (frames)
HoldEnabled	32u	Setting to enable or disable the hold filter: 0 - Disable 1 - Enable
SmoothingWindowMin	32u	Constraint for smoothing window minimum (frames).
SmoothingWindowMax	32u	Constraint for smoothing window maximum (frames).
LinkIds	32u	List of linkable measurements.

## Measurements / PartStudTipX

A Part Stud Tip X element defines settings for a Part Stud Tip X measurement.

### *Part Stud Tip X Child Elements*

Element	Type	Description
Name	String	Setting for measurement name.
DecisionMin	64f	Setting for decision threshold minimum (mm).
DecisionMax	64f	Setting for decision threshold maximum (mm).
StudRadius	64f	Setting for nominal radius (mm)
StudHeight	64f	Setting for the stud height (mm)
BaseHeight	64f	Setting for the stud base height (mm)
TipHeight	64f	Setting for the stud tip height (mm)
RegionEnabled	32u	Setting to enable/disable region: 0 - Disable 1 - Enable
Region	PartRegion3 d	Measurement region
RefRegions	(Collection)	Reference regions, contains 1 or 2 RefRegion elements
AutoRefRegionEnabled	32u	Setting to enable/disable reference region: 0 - Disable 1 - Enable
RefRegionsEnabled	32u	0 - Reference regions disabled 1 - Reference regions enabled
RefRegions/RefRegion	PartRegion	Reference region
AutoTiltCorrectionEnabled	32u	Setting to enable/disable tilt correction: 0 - Disable

Element	Type	Description
		1 - Enable
TiltXAngle	64f	Setting for manual tilt correction angle X
TiltYAngle	64f	Setting for manual tilt correction angle Y
LinkEnabled	32u	Setting to enable/disable linking: 0 - Disable 1 - Enable
Link	32u	Measurement ID to link with
Scale	64f	Setting for scale factor to apply to measurement value
Offset	64f	Setting for offset to apply to measurement value
SmoothingEnabled	32u	Setting to enable or disable the smoothing filter: 0 - Disable 1 - Enable
SmoothingWindow	32u	Setting for the smoothing window (frames)
HoldEnabled	32u	Setting to enable or disable the hold filter: 0 - Disable 1 - Enable
SmoothingWindowMin	32u	Constraint for smoothing window minimum (frames).
SmoothingWindowMax	32u	Constraint for smoothing window maximum (frames).
LinkIds	32u	List of linkable measurements.

## Measurements / PartStudTipY

A Part Stud Tip Y element defines settings for a Part Stud Tip Y measurement.

### Part Stud Tip Y Child Elements

Element	Type	Description
Name	String	Setting for measurement name.
DecisionMin	64f	Setting for decision threshold minimum (mm).
DecisionMax	64f	Setting for decision threshold maximum (mm).
StudRadius	64f	Setting for nominal radius (mm)
StudHeight	64f	Setting for the stud height (mm)
BaseHeight	64f	Setting for the stud base height (mm)
TipHeight	64f	Setting for the stud tip height (mm)
RegionEnabled	32u	Setting to enable/disable region: 0 - Disable 1 - Enable
Region	PartRegion3	Measurement region

Element	Type	Description
	d	
RefRegions	(Collection)	Reference regions, contains 1 or 2 RefRegion elements
AutoRefRegionEnabled	32u	Setting to enable/disable reference region: 0 - Disable 1 - Enable
RefRegionsEnabled	32u	0 - Reference regions disabled 1 - Reference regions enabled
RefRegions/RefRegion	PartRegion	Reference region
AutoTiltCorrectionEnabled	32u	Setting to enable/disable tilt correction: 0 - Disable 1 - Enable
TiltXAngle	64f	Setting for manual tilt correction angle X
TiltYAngle	64f	Setting for manual tilt correction angle Y
LinkEnabled	32u	Setting to enable/disable linking: 0 - Disable 1 - Enable
Link	32u	Measurement ID to link with
Scale	64f	Setting for scale factor to apply to measurement value
Offset	64f	Setting for offset to apply to measurement value
SmoothingEnabled	32u	Setting to enable or disable the smoothing filter: 0 - Disable 1 - Enable
SmoothingWindow	32u	Setting for the smoothing window (frames)
HoldEnabled	32u	Setting to enable or disable the hold filter: 0 - Disable 1 - Enable
SmoothingWindowMin	32u	Constraint for smoothing window minimum (frames).
SmoothingWindowMax	32u	Constraint for smoothing window maximum (frames).
LinkIds	32u	List of linkable measurements.

## Measurements / PartStudTipZ

A Part Stud Tip Z element defines settings for a Part Stud Tip Z measurement.

### *Part Stud Tip Z Child Elements*

Element	Type	Description
Name	String	Setting for measurement name.
DecisionMin	64f	Setting for decision threshold minimum (mm).
DecisionMax	64f	Setting for decision threshold maximum (mm).

<b>Element</b>	<b>Type</b>	<b>Description</b>
StudRadius	64f	Setting for nominal radius (mm)
StudHeight	64f	Setting for the stud height (mm)
BaseHeight	64f	Setting for the stud base height (mm)
TipHeight	64f	Setting for the stud tip height (mm)
RegionEnabled	32u	Setting to enable/disable region: 0 - Disable 1 - Enable
Region	PartRegion3 d	Measurement region
RefRegions	(Collection)	Reference regions, contains 1 or 2 RefRegion elements
AutoRefRegionEnabled	32u	Setting to enable/disable reference region: 0 - Disable 1 - Enable
RefRegionsEnabled	32u	0 - Reference regions disabled 1 - Reference regions enabled
RefRegions/RefRegion	PartRegion	Reference region
AutoTiltCorrectionEnabled	32u	Setting to enable/disable tilt correction: 0 - Disable 1 - Enable
TiltXAngle	64f	Setting for manual tilt correction angle X
TiltYAngle	64f	Setting for manual tilt correction angle Y
LinkEnabled	32u	Setting to enable/disable linking: 0 - Disable 1 - Enable
Link	32u	Measurement ID to link with
Scale	64f	Setting for scale factor to apply to measurement value
Offset	64f	Setting for offset to apply to measurement value
SmoothingEnabled	32u	Setting to enable or disable the smoothing filter: 0 - Disable 1 - Enable
SmoothingWindow	32u	Setting for the smoothing window (frames)
HoldEnabled	32u	Setting to enable or disable the hold filter: 0 - Disable 1 - Enable
SmoothingWindowMin	32u	Constraint for smoothing window minimum (frames).
SmoothingWindowMax	32u	Constraint for smoothing window maximum (frames).
LinkIds	32u	List of linkable measurements.

## Measurements / PartStudBaseX

A Part Stud Base X element defines settings for a Part Stud Base X measurement.

### *Part Stud Base X Child Elements*

<b>Element</b>	<b>Type</b>	<b>Description</b>
Name	String	Setting for measurement name.
DecisionMin	64f	Setting for decision threshold minimum (mm).
DecisionMax	64f	Setting for decision threshold maximum (mm).
StudRadius	64f	Setting for nominal radius (mm)
StudHeight	64f	Setting for the stud height (mm)
BaseHeight	64f	Setting for the stud base height (mm)
TipHeight	64f	Setting for the stud tip height (mm)
RegionEnabled	32u	Setting to enable/disable region: 0 - Disable 1 - Enable
Region	PartRegion3 d	Measurement region
RefRegions	(Collection)	Reference regions, contains 1 or 2 RefRegion elements
AutoRefRegionEnabled	32u	Setting to enable/disable reference region: 0 - Disable 1 - Enable
RefRegionsEnabled	32u	0 - Reference regions disabled 1 - Reference regions enabled
RefRegions/RefRegion	PartRegion	Reference region
AutoTiltCorrectionEnabled	32u	Setting to enable/disable tilt correction: 0 - Disable 1 - Enable
TiltXAngle	64f	Setting for manual tilt correction angle X
TiltYAngle	64f	Setting for manual tilt correction angle Y
LinkEnabled	32u	Setting to enable/disable linking: 0 - Disable 1 - Enable
Link	32u	Measurement ID to link with
Scale	64f	Setting for scale factor to apply to measurement value
Offset	64f	Setting for offset to apply to measurement value
SmoothingEnabled	32u	Setting to enable or disable the smoothing filter: 0 - Disable 1 - Enable
SmoothingWindow	32u	Setting for the smoothing window (frames)
HoldEnabled	32u	Setting to enable or disable the hold filter:

Element	Type	Description
		0 - Disable 1 - Enable
SmoothingWindowMin	32u	Constraint for smoothing window minimum (frames).
SmoothingWindowMax	32u	Constraint for smoothing window maximum (frames).
LinkIds	32u	List of linkable measurements.

## Measurements / PartStudBaseY

A Part Stud Base Y element defines settings for a Part Stud Base Y measurement.

### Part Stud Base Y Child Elements

Element	Type	Description
Name	String	Setting for measurement name.
DecisionMin	64f	Setting for decision threshold minimum (mm).
DecisionMax	64f	Setting for decision threshold maximum (mm).
StudRadius	64f	Setting for nominal radius (mm)
StudHeight	64f	Setting for the stud height (mm)
BaseHeight	64f	Setting for the stud base height (mm)
TipHeight	64f	Setting for the stud tip height (mm)
RegionEnabled	32u	Setting to enable/disable region: 0 - Disable 1 - Enable
Region	PartRegion3 d	Measurement region
RefRegions	(Collection)	Reference regions, contains 1 or 2 RefRegion elements
AutoRefRegionEnabled	32u	Setting to enable/disable reference region: 0 - Disable 1 - Enable
RefRegionsEnabled	32u	0 - Reference regions disabled 1 - Reference regions enabled
RefRegions/RefRegion	PartRegion	Reference region
AutoTiltCorrectionEnabled	32u	Setting to enable/disable tilt correction: 0 - Disable 1 - Enable
TiltXAngle	64f	Setting for manual tilt correction angle X
TiltYAngle	64f	Setting for manual tilt correction angle Y
LinkEnabled	32u	Setting to enable/disable linking: 0 - Disable 1 - Enable

Element	Type	Description
Link	32u	Measurement ID to link with
Scale	64f	Setting for scale factor to apply to measurement value
Offset	64f	Setting for offset to apply to measurement value
SmoothingEnabled	32u	Setting to enable or disable the smoothing filter: 0 - Disable 1 - Enable
SmoothingWindow	32u	Setting for the smoothing window (frames)
HoldEnabled	32u	Setting to enable or disable the hold filter: 0 - Disable 1 - Enable
SmoothingWindowMin	32u	Constraint for smoothing window minimum (frames).
SmoothingWindowMax	32u	Constraint for smoothing window maximum (frames).
LinkIds	32u	List of linkable measurements.

## Measurements / PartStudBaseZ

A Part Stud Base Z element defines settings for a Part Stud Base Z measurement.

### *Part Stud Base Y Child Elements*

Element	Type	Description
Name	String	Setting for measurement name.
DecisionMin	64f	Setting for decision threshold minimum (mm).
DecisionMax	64f	Setting for decision threshold maximum (mm).
StudRadius	64f	Setting for nominal radius (mm)
StudHeight	64f	Setting for the stud height (mm)
BaseHeight	64f	Setting for the stud base height (mm)
TipHeight	64f	Setting for the stud tip height (mm)
RegionEnabled	32u	Setting to enable/disable region: 0 - Disable 1 - Enable
Region	PartRegion3 d	Measurement region
RefRegions	(Collection)	Reference regions, contains 1 or 2 RefRegion elements
AutoRefRegionEnabled	32u	Setting to enable/disable reference region: 0 - Disable 1 - Enable
RefRegionsEnabled	32u	0 - Reference regions disabled 1 - Reference regions enabled
RefRegions/RefRegion	PartRegion	Reference region
AutoTiltCorrectionEnabled	32u	Setting to enable/disable tilt correction:

Element	Type	Description
		0 - Disable 1 - Enable
TiltXAngle	64f	Setting for manual tilt correction angle X
TiltYAngle	64f	Setting for manual tilt correction angle Y
LinkEnabled	32u	Setting to enable/disable linking: 0 - Disable 1 - Enable
Link	32u	Measurement ID to link with
Scale	64f	Setting for scale factor to apply to measurement value
Offset	64f	Setting for offset to apply to measurement value
SmoothingEnabled	32u	Setting to enable or disable the smoothing filter: 0 - Disable 1 - Enable
SmoothingWindow	32u	Setting for the smoothing window (frames)
HoldEnabled	32u	Setting to enable or disable the hold filter: 0 - Disable 1 - Enable
SmoothingWindowMin	32u	Constraint for smoothing window minimum (frames).
SmoothingWindowMax	32u	Constraint for smoothing window maximum (frames).
LinkIds	32u	List of linkable measurements.

## Measurements / PartStudBaseRadius

A Part Stud Base Radius element defines settings for a Part Stud Base Radius measurement.

### Part Stud Base Radius Child Elements

Element	Type	Description
Name	String	Setting for measurement name.
DecisionMin	64f	Setting for decision threshold minimum (mm).
DecisionMax	64f	Setting for decision threshold maximum (mm).
StudRadius	64f	Setting for nominal radius (mm)
StudHeight	64f	Setting for the stud height (mm)
BaseHeight	64f	Setting for the stud base height (mm)
TipHeight	64f	Setting for the stud tip height (mm)
RegionEnabled	32u	Setting to enable/disable region: 0 - Disable 1 - Enable
Region	PartRegion3 d	Measurement region

<b>Element</b>	<b>Type</b>	<b>Description</b>
RefRegions	(Collection)	Reference regions, contains 1 or 2 RefRegion elements
AutoRefRegionEnabled	32u	Setting to enable/disable reference region: 0 - Disable 1 - Enable
RefRegionsEnabled	32u	0 - Reference regions disabled 1 - Reference regions enabled
RefRegions/RefRegion	PartRegion	Reference region
AutoTiltCorrectionEnabled	32u	Setting to enable/disable tilt correction: 0 - Disable 1 - Enable
TiltXAngle	64f	Setting for manual tilt correction angle X
TiltYAngle	64f	Setting for manual tilt correction angle Y
LinkEnabled	32u	Setting to enable/disable linking: 0 - Disable 1 - Enable
Link	32u	Measurement ID to link with
Scale	64f	Setting for scale factor to apply to measurement value
Offset	64f	Setting for offset to apply to measurement value
SmoothingEnabled	32u	Setting to enable or disable the smoothing filter: 0 - Disable 1 - Enable
SmoothingWindow	32u	Setting for the smoothing window (frames)
HoldEnabled	32u	Setting to enable or disable the hold filter: 0 - Disable 1 - Enable
SmoothingWindowMin	32u	Constraint for smoothing window minimum (frames).
SmoothingWindowMax	32u	Constraint for smoothing window maximum (frames).
LinkIds	32u	List of linkable measurements.

## Measurements / SurfacePlaneXAngle

A Part Plane X Angle element defines settings for a Part Plane X Angle measurement.

### *Part Plane X Child Elements*

<b>Element</b>	<b>Type</b>	<b>Description</b>
Name	String	Setting for measurement name.
DecisionMin	64f	Setting for decision threshold minimum (mm).
DecisionMax	64f	Setting for decision threshold maximum (mm).
RegionsEnabled	32u	Setting to enable/disable region: 0 - Disable

Element	Type	Description
		1 - Enable
Regions	(Collection)	Contains 0, 1, or 2 PartRegion3d elements.
LinkEnabled	32u	Setting to enable/disable linking: 0 - Disable 1 - Enable
Link	32u	Measurement ID to link with
Scale	64f	Setting for scale factor to apply to measurement value
Offset	64f	Setting for offset to apply to measurement value
SmoothingEnabled	32u	Setting to enable or disable the smoothing filter: 0 - Disable 1 - Enable
SmoothingWindow	32u	Setting for the smoothing window (frames)
HoldEnabled	32u	Setting to enable or disable the hold filter: 0 - Disable 1 - Enable
SmoothingWindowMin	32u	Constraint for smoothing window minimum (frames).
SmoothingWindowMax	32u	Constraint for smoothing window maximum (frames).
LinkIds	32u	List of linkable measurements.

## Measurements / SurfacePlaneYAngle

A Part Plane Y Angle element defines settings for a Part Plane Y Angle measurement.

### Part Plane Y Child Elements

Element	Type	Description
Name	String	Setting for measurement name.
DecisionMin	64f	Setting for decision threshold minimum (mm).
DecisionMax	64f	Setting for decision threshold maximum (mm).
RegionsEnabled	32u	Setting to enable/disable region: 0 - Disable 1 - Enable
Regions	(Collection)	Contains 0, 1, or 2 PartRegion3d elements.
LinkEnabled	32u	Setting to enable/disable linking: 0 - Disable 1 - Enable
Link	32u	Measurement ID to link with
Scale	64f	Setting for scale factor to apply to measurement value
Offset	64f	Setting for offset to apply to measurement value
SmoothingEnabled	32u	Setting to enable or disable the smoothing filter: 0 - Disable

Element	Type	Description
		1 - Enable
SmoothingWindow	32u	Setting for the smoothing window (frames)
HoldEnabled	32u	Setting to enable or disable the hold filter: 0 - Disable 1 - Enable
SmoothingWindowMin	32u	Constraint for smoothing window minimum (frames).
SmoothingWindowMax	32u	Constraint for smoothing window maximum (frames).
LinkIds	32u	List of linkable measurements.
Element	Type	Description

## Measurements / SurfacePlaneZOffset

A Part Plane Z Offset element defines settings for a Part Plane Z Offset measurement.

### Part Plane Z Offset Child Elements

Element	Type	Description
Name	String	Setting for measurement name.
DecisionMin	64f	Setting for decision threshold minimum (mm).
DecisionMax	64f	Setting for decision threshold maximum (mm).
RegionsEnabled	32u	Setting to enable/disable region: 0 - Disable 1 - Enable
Regions	(Collection)	Contains 0, 1, or 2 PartRegion3d elements.
LinkEnabled	32u	Setting to enable/disable linking: 0 - Disable 1 - Enable
Link	32u	Measurement ID to link with
Scale	64f	Setting for scale factor to apply to measurement value
Offset	64f	Setting for offset to apply to measurement value
SmoothingEnabled	32u	Setting to enable or disable the smoothing filter: 0 - Disable 1 - Enable
SmoothingWindow	32u	Setting for the smoothing window (frames)
HoldEnabled	32u	Setting to enable or disable the hold filter: 0 - Disable 1 - Enable
SmoothingWindowMin	32u	Constraint for smoothing window minimum (frames).
SmoothingWindowMax	32u	Constraint for smoothing window maximum (frames).
LinkIds	32u	List of linkable measurements.
Element	Type	Description

## Measurements / PartPositionX

A Part Position X element defines settings for a Part Position X measurement.

### *Part Position X Child Elements*

<b>Element</b>	<b>Type</b>	<b>Description</b>
Name	String	Setting for measurement name.
DecisionMin	64f	Setting for decision threshold minimum (mm).
DecisionMax	64f	Setting for decision threshold maximum (mm).
RegionEnabled	32u	Setting to enable/disable region: 0 - Disable 1 - Enable
Region	PartRegion3d	Measurement region
LinkEnabled	32u	Setting to enable/disable linking: 0 - Disable 1 - Enable
Link	32u	Measurement ID to link with
Scale	64f	Setting for scale factor to apply to measurement value
Offset	64f	Setting for offset to apply to measurement value
Feature	SurfaceFeature3d	Measurement feature.
SmoothingEnabled	32u	Setting to enable or disable the smoothing filter: 0 - Disable 1 - Enable
SmoothingWindow	32u	Setting for the smoothing window (frames)
HoldEnabled	32u	Setting to enable or disable the hold filter: 0 - Disable 1 - Enable
SmoothingWindowMin	32u	Constraint for smoothing window minimum (frames).
SmoothingWindowMax	32u	Constraint for smoothing window maximum (frames).
LinkIds	32u	List of linkable measurements.

## Measurements / PartPositionY

A Part Position Y element defines settings for a Part Position Y measurement.

### *Part Position Y Child Elements*

<b>Element</b>	<b>Type</b>	<b>Description</b>
Name	String	Setting for measurement name.
DecisionMin	64f	Setting for decision threshold minimum (mm).
DecisionMax	64f	Setting for decision threshold maximum (mm).
RegionEnabled	32u	Setting to enable/disable region: 0 - Disable

Element	Type	Description
		1 - Enable
Region	PartRegion3d	Measurement region
LinkEnabled	32u	Setting to enable/disable linking: 0 - Disable 1 - Enable
Link	32u	Measurement ID to link with
Scale	64f	Setting for scale factor to apply to measurement value
Offset	64f	Setting for offset to apply to measurement value
Feature	SurfaceFeature3d	Measurement feature.
SmoothingEnabled	32u	Setting to enable or disable the smoothing filter: 0 - Disable 1 - Enable
SmoothingWindow	32u	Setting for the smoothing window (frames)
HoldEnabled	32u	Setting to enable or disable the hold filter: 0 - Disable 1 - Enable
SmoothingWindowMin	32u	Constraint for smoothing window minimum (frames).
SmoothingWindowMax	32u	Constraint for smoothing window maximum (frames).
LinkIds	32u	List of linkable measurements.

## Measurements / PartPositionZ

A Part Position Z element defines settings for a Part Position Z measurement.

### *Part Position X Child Elements*

Element	Type	Description
Name	String	Setting for measurement name.
DecisionMin	64f	Setting for decision threshold minimum (mm).
DecisionMax	64f	Setting for decision threshold maximum (mm).
RegionEnabled	32u	Setting to enable/disable region: 0 - Disable 1 - Enable
Region	PartRegion3d	Measurement region
LinkEnabled	32u	Setting to enable/disable linking: 0 - Disable 1 - Enable
Link	32u	Measurement ID to link with
Scale	64f	Setting for scale factor to apply to measurement value
Offset	64f	Setting for offset to apply to measurement value

Element	Type	Description
Feature	SurfaceFeature3d	Measurement feature.
SmoothingEnabled	32u	Setting to enable or disable the smoothing filter: 0 - Disable 1 - Enable
SmoothingWindow	32u	Setting for the smoothing window (frames)
HoldEnabled	32u	Setting to enable or disable the hold filter: 0 - Disable 1 - Enable
SmoothingWindowMin	32u	Constraint for smoothing window minimum (frames).
SmoothingWindowMax	32u	Constraint for smoothing window maximum (frames).
LinkIds	32u	List of linkable measurements.

## Measurements / SurfaceTextureRoughness

A Surface Texture Roughness element defines settings for a Surface Texture Roughness measurement.

### Surface Texture Roughness Child Elements

Element	Type	Description
Name	String	Setting for measurement name.
DecisionMin	64f	Setting for decision threshold minimum (mm).
DecisionMax	64f	Setting for decision threshold maximum (mm).
Region	SurfaceCircleRegion	Measurement region
LinkEnabled	32u	Setting to enable/disable linking: 0 - Disable 1 - Enable
Link	32u	Measurement ID to link with
Scale	64f	Setting for scale factor to apply to measurement value
Offset	64f	Setting for offset to apply to measurement value
SmoothingEnabled	32u	Setting to enable or disable the smoothing filter: 0 - Disable 1 - Enable
SmoothingWindow	32u	Setting for the smoothing window (frames)
HoldEnabled	32u	Setting to enable or disable the hold filter: 0 - Disable 1 - Enable
SmoothingWindowMin	32u	Constraint for smoothing window minimum (frames).
SmoothingWindowMax	32u	Constraint for smoothing window maximum (frames).
LinkIds	32u	List of linkable measurements.

## Measurements / SurfaceTextureInvalidCount

A Surface Texture Invalid Count element defines settings for a Surface Texture Invalid Count measurement.

### *Surface Texture Invalid Count Child Elements*

<b>Element</b>	<b>Type</b>	<b>Description</b>
Name	String	Setting for measurement name.
DecisionMin	64f	Setting for decision threshold minimum (mm).
DecisionMax	64f	Setting for decision threshold maximum (mm).
Region	SurfaceCircleRegion	Measurement region
LinkEnabled	32u	Setting to enable/disable linking: 0 - Disable 1 - Enable
Link	32u	Measurement ID to link with
Scale	64f	Setting for scale factor to apply to measurement value
Offset	64f	Setting for offset to apply to measurement value
SmoothingEnabled	32u	Setting to enable or disable the smoothing filter: 0 - Disable 1 - Enable
SmoothingWindow	32u	Setting for the smoothing window (frames)
HoldEnabled	32u	Setting to enable or disable the hold filter: 0 - Disable 1 - Enable
SmoothingWindowMin	32u	Constraint for smoothing window minimum (frames).
SmoothingWindowMax	32u	Constraint for smoothing window maximum (frames).
LinkIds	32u	List of linkable measurements.
Element	Type	Description

## Measurements / Script

A Script element defines settings for a script measurement.

### *Script Child Elements*

<b>Element</b>	<b>Type</b>	<b>Description</b>
Name	String	Setting for measurement name.
Code	String	Script code.

## Outputs

The Outputs element has the following sub-element types: Ethernet, Serial, Analog, and Digital Output. Each of these sub-elements defines the output settings for a different type of Gocator output.

The *Source* identifiers that are used with *Video*, *profile*, *part* and *intensity* outputs are *profile source identifiers*. See *Profile Sources* (page 256) for more information.

The *Source* identifiers that are used with *Value* and *Decision* outputs correspond to the measurement identifiers defined in the Measurements element, for example:

```
<ProfileMeasurement>    ...
  <Measurements>
    <Width id="1000">    ...
    <Height id="2000"> ...
  </Measurements>
  <Outputs>
    <Ethernet>          ...
    <Decision>1000,2000</Decision>    ...
```

## Ethernet

The Ethernet element defines settings for Ethernet output.

### *Ethernet Child Elements*

Element	Type	Description
Protocol	32s	Setting for selected protocol: 0 – Gocator 1 – Modbus TCP 2 – EtherNet/IP 3 – ASCII
Video	String	Setting for selected video sources (comma-delimited list).
Profile	String	Setting for selected profile sources (comma-delimited list).
ProfileIntensity	String	Setting for selected profile intensity sources (comma-delimited list).
RawProfile	String	Setting for selected raw profile sources (comma-delimited list).
Part	String	Setting for selected part sources (comma-delimited list).
PartIntensity	String	Setting for selected part intensity sources (comma-delimited list).
Value	String	Setting for selected value sources (comma-delimited list).
Decision	String	Setting for selected decision sources (comma-delimited list).
AsciiOperation	32s	Setting for the ASCII protocol operation mode: 0 – Asynchronous 1 – Polling
AsciiControlPort	32u	Setting for the ASCII protocol control channel port number.
AsciiHealthPort	32u	Setting for the ASCII protocol health channel port number.
AsciiDataPort	32u	Setting for the ASCII protocol data channel port number.
AsciiDelimiter	String	Setting for the ASCII protocol delimiter character.
AsciiTerminator	String	Setting for the ASCII protocol terminator character.
AsciiInvalidValue	String	Setting for the ASCII protocol invalid value string
AsciiCustomFormatEnabled	32u	Setting for the ASCII custom format:

Element	Type	Description
		0 – Disable 1 – Enable
AsciiCustomDataFormat	String	Setting for the format of ASCII custom data string.
EIPBufferEnabled	32u	Setting for enable/dissable EIP buffering: 0 – Disable 1 – Enable
ModbusBufferEnabled	32u	Setting for enable/dissable Modbus buffering: 0 – Disable 1 – Enable
VideoOptions	String	Constraint for eligible video sources (comma-delimited list).
ProfileOptions	String	Constraint for eligible profile sources (comma-delimited list).
ProfileIntensityOptions	String	Constraint for eligible profile intensity sources (comma-delimited list).
RawProfileOptions	String	Constraint for eligible raw profile sources (comma-delimited list).
PartOptions	String	Constraint for eligible part sources (comma-delimited list).
PartIntensityOptions	String	Constraint for eligible part intensity sources (comma-delimited list).
ValueOptions	String	Constraint for eligible value sources (comma-delimited list).
DecisionOptions	String	Constraint for eligible decision sources (comma-delimited list).

## Serial

The Serial element defines settings for Serial output.

### *Serial Child Elements*

Element	Type	Description
Value	String	Setting for selected value sources (comma-delimited list).
Decision	String	Setting for selected decision sources (comma-delimited list).
Protocol	32s	Setting for the serial protocol: 0 – Gocator 1 – Selcom Serial  Selcom Serial is only available on the Gocator 2340-3B-N-12 model
SelcomRate	32u	Setting for Selcom Serial output rate (bits/s)
SelcomFormat	32s	Setting for Selcom Serial output format: 0 – 14-bit 1 – 14-bit with search/track information 2 – 12-bit 3 – 12-bit with search/track information  The options are only available for the Gocator 2340-3B-N-12.
AsciiDelimiter	String	Setting for the ASCII protocol delimiter character.

Element	Type	Description
AsciiTerminator	String	Setting for the ASCII protocol terminator character.
AsciiInvalidValue	String	Setting for the ASCII protocol invalid value string
AsciiCustomFormatEnabled	32u	Setting for the ASCII custom format 0 – Disable 1 – Enable
AsciiCustomDataFormat	String	Setting for the format of ASCII custom data string.
ValueOptions	String	Constraint for eligible value sources (comma-delimited list).
DecisionOptions	String	Constraint for eligible decision sources (comma-delimited list).
ProtocolOptions	String	Constraint for eligible protocol options (comma-delimited list)
SelcomRateOptions	String	Constraint for Selcom Serial rate options (comma-delimited list)
SelcomFormatOptions	String	Constraint for Selcom Serial format options (comma-delimited list)

## Analog

The Analog element defines settings for Analog output.

The range of valid measurement values [DataScaleMin, DataScaleMax] is scaled linearly to the specified current range [CurrentMin, CurrentMax].

Only one Value or Decision source can be selected at a time.

### Analog Child Elements

Element	Type	Description
CurrentMin	64f	Setting for minimum output current (mA).
CurrentMax	64f	Setting for maximum output current (mA).
CurrentInvalid	64f	Setting for invalid output current (mA).
CurrentInvalidEnable	32u	0 – Output keeps currently value if measurement is invalid. 1 – Outputs CurrentInvalid if measurement is invalid.
DataScaleMin	64f	Setting for measurement value associated with the minimum current.
DataScaleMax	64f	Setting for measurement value associated with the maximum current.
Value	32u	Setting for selected value source.
Decision	32u	Setting for selected decision source.
CurrentLimitMin	64f	Constraint for minimum output current (mA).
CurrentLimitMax	64f	Constraint for maximum output current (mA).
ValueOptions	String	Constraint for eligible value sources (comma-delimited list).
DecisionOptions	String	Constraint for eligible decision sources (comma-delimited list).
Event	32s	Setting for which event control the output: 1 – Measurement 2 – Software
ScheduleEnable	32u	Setting for scheduled output mode. When unscheduled, output updates

Element	Type	Description
		immediately. When scheduled, output updates according to a target value in software command, or a delay. 0 - Not scheduled 1 - Scheduled
Delay	64f	Setting for output delay. The delay is measured from exposure (first exposure for multiple exposure) to when output is scheduled. Ignored when ScheduleEnable is 0. The units depends on SystemDomain.

 The delay specifies the time or position at which the analog output activates. Upon activation, there is an additional delay before the analog output settles at the correct value.

## DigitalOutput

A DigitalOutput element defines settings for a digital output. There are two DigitalOutput elements, each identified by a unique id attribute (0 and 1):

```
<DigitalOutput id="0">
```

### DigitalOutput Child Elements

Element	Type	Description
PassMode	32u	Setting to specify how the state of the output is defined: 0 - Pass if decision is true 1 - Pass if decision is false 2 - Pass always
PulseWidth	32u	Setting for digital pulse width (us).
Decision	String	Setting for selected decision sources (comma-delimited list).
PulseWidthMin	32u	Constraint for minimum pulse width (us).
PulseWidthMax	32u	Constraint for maximum pulse width (us).
DecisionOptions	String	Constraint for eligible decision sources (comma-delimited list).
SignalType	32s	Setting for signal type: 0 - Pulsed output 1 - Continuous output
Event	32s	Setting for which event control the output: 1 - Measurement 2 - Software 4 - Exposure
ScheduleEnable	32u	Setting for scheduled output mode. When unscheduled, output updates immediately. When scheduled, output updates according to a target value in software command, or a delay. 0 - Not scheduled 1 - Scheduled
Delay	64f	Setting for output delay. The delay is measured from exposure (first exposure for multiple exposure) to when output is scheduled. Ignored when ScheduleEnable is 0. The units depends on SystemDomain.

# Calibration File

The sensor calibration file contains information about the physical system setup that is used to:

- Transform data from sensor coordinate system to another coordinate system (e.g., world)
- Define encoder resolution for encoder-based triggering
- Define the travel offset (Y offset) between sensors for staggered operation

Use Read and Write File command to modify the transformation file.

## Calibration Example:

```
<?xml version="1.0" ?>
<SysCal version="2">
  <YResolution>0</YResolution>
  <YSpeed>0</YSpeed>
  <Entries>
    <Entry id="0">
      <X>-2.3650924829</X>
      <Y>0.0</Y>
      <Z>123.4966803469</Z>
      <XAngle>5.7478302588</XAngle>
      <YAngle>3.7078302555</XAngle>
      <ZAngle>2.7078302556</XAngle>
      <Orientation>0</Orientation>
    </Entry>
    <Entry id="1">
      <X>0</X>
      <Y>0.0</Y>
      <Z>123.4966803469</Z>
      <XAngle>5.7478302588</XAngle>
      <YAngle>3.7078302555</XAngle>
      <ZAngle>2.7078302556</XAngle>
      <Orientation>0</Orientation>
    </Entry>
  </Entries>
</SysCal>
```

## SysCal

The SysCal element contains the calibration record for both the Main and the Buddy sensor. The version attribute defines the version of the record format.

```
<SysCal version="2">
```

### *SysCal Child Elements*

<b>Element</b>	<b>Type</b>	<b>Description</b>
YResolution	64f	Encoder Resolution (mm/tick).
YSpeed	64f	Travel Speed (mm/s).

### **Entries**

An Entry element defines the transformation for a sensor. There is one entry element per sensor, identified by a unique id attribute (0 for main and 1 for buddy):

```
<Entry id="0">
```

### *Entry Child Elements*

<b>Element</b>	<b>Type</b>	<b>Description</b>
X	64f	Translation in the X axis (mm).
Y	64f	Translation in the Y axis (mm).
Z	64f	Translation in the Z axis (mm).
XAngle	64f	Rotation about Y axis (degrees).
YAngle	64f	Rotation about X axis (degrees).
ZAngle	64f	Rotation about Z axis (degrees).
Orientation	32s	Direction of X axis: 0 – Normal 1 – Reverse

The rotation (counter-clockwise in the X-Z plane) is performed before the translation. If a right-handed system is wanted instead of the normal orientation (e.g., if sensors are opposite in the Y axis, see page 44 in the manual), then Orientation can be set to 1 to flip the coordinate system.

# Protocols

The following sections describe the protocols that Gocator sensors support.

## Gocator Protocol

This section describes TCP and UDP commands and data formats used by a client computer to communicate with Gocator sensors. Network communication enables the client to:

- Discover Main and Buddy sensors on an IP network and re-configure their network addresses.
- Configure Main and Buddy sensors.
- Send commands to run sensors, provide software triggers, read/write files, etc.
- Receive data, health, and diagnostic messages.
- Upgrade firmware.

The Concepts section defines network connection types (Discovery, Control, Upgrade, Data, and Health), common data types, and other terminologies. Subsequent sections provide details about network commands and data formats.

The Gocator SDK provides open source C language libraries that implement the network commands and data formats defined in this section. See *Software Development Kit* (page 308) for more information.

## Concepts

### Discovery

Sensors ship with the following default network configuration:

Setting	Default
DHCP	0 (disabled)
IP Address	192.168.1.10
Subnet Mask	255.255.255.0
Gateway	0.0.0.0 (disabled)

The Get Address and Set Address discovery commands can be used to modify a sensor's network configuration. Discovery commands are UDP broadcast messages:

Destination Address	Destination Port
255.255.255.255	3220

When a sensor accepts a discovery command, it will send a UDP broadcast response:

Destination Address	Destination Port
255.255.255.255	Port of command sender.

The use of UDP broadcasts for discovery enables a client computer to locate a sensor when the sensor and client are configured for different subnets. All you need to know is the serial number of the sensor in order to locate it on an IP network.

## Command Channels

A client can send commands and receive responses over the Control and Upgrade TCP channels.

### Command Channels

Channel	Port	Description
Control	3190	Sensor accepts commands for most operations.
Upgrade	3192	Sensor accepts commands for firmware upgrades.

The Control and Upgrade channels can be connected simultaneously, but the sensor will accept only a single connection on each port. If an additional connection is attempted on a port that is already connected, the previous connection will be closed and the new connection will be accepted.

## Result Channels

A client can receive data messages from a Gocator sensor by connecting to the Data or Health TCP channels.

### Result Channels

Channel	Port	Description
Data	3196	Sensor sends data messages.
Health	3194	Sensor sends health messages.

The ports above can be connected simultaneously and the sensor will also accept multiple connections on each port.

## Modes

A Gocator system can operate in the following modes.

### System Modes

Mode	Description
Video	Sends raw video.
AlignCalibrate	Performs alignment calibration.
TravelCalibrate	Performs travel calibration.
ExpCalibrate	Performs automatic exposure adjustment.
ProfileTemplate	Performs profile template registration.
ProfileMeasure	Performs profile measurements (default mode).

Mode	Description
PartMeasure	Performs part detection and measurements .
Raw	Performs profiling and output raw profile data.

## Buddy Communication Channels

The peer-to-peer control channels are used by Gocator sensors to communicate between sensors.

Channel	Port	Description
Discovery	2002, 2005, 2008	Gocator peer discovery port. UDP broadcasts on the subnet are sent once every second.
Command	2002 to 2015	Gocator request and response ports. Gocator uses UDP communications on these ports for configuration and reporting.
Data	2500	Main Gocator listens on this port for TCP traffic from the Buddy sensor. Buddy sensor communicates using a free port available at the time.

## States

A Gocator system can be in one of three states: Conflict, Ready, or Running. The Start and Stop commands are sent by the client to change the current state. The sensor can be configured to boot in either the Ready or Running state.

In the Ready state, a sensor can be configured. In the Running state, a sensor will respond to input signals, perform measurements, drive its outputs, and send data messages to the client. Disconnecting to command channel will change the sensor from the Running state to the Ready state.

The Conflict state indicates that a sensor has been configured with a Buddy sensor but the Buddy sensor is not present on the network. The sensor will not accept some commands until the Change Buddy command is used to remove the configured Buddy.

## Versions and Upgrades

After connecting to a Gocator device, you can use the Get Protocol Version and Get System Info commands to establish protocol and firmware versions.

### Versions

Version	Description
Protocol version	Sensor protocol version (major, minor).
Firmware version	Sensor firmware version (major, minor, release, build).

*Protocol version* refers to the version of the Gocator Protocol supported by the *connected sensor* (the sensor to which a command connection is established), and consists of major and minor parts. The minor part is updated when backward-compatible additions are made to the Gocator Protocol. The major part will be updated in the event that breaking changes are made to the Gocator Protocol.

*Firmware version* refers to the version of the Gocator's firmware installed on each individual sensor. The client can upgrade the Gocator's firmware by sending the Upgrade command. Firmware upgrade files

are available from the downloads section under the support tab on the LMI web site. See *Firmware Upgrade* (page 60) for more information on obtaining the latest firmware.

Every Gocator sensor contains factory backup firmware. If a firmware upgrade command fail (e.g., power is interrupted), the factory backup firmware will be loaded when the sensor is reset or power cycled. In this case, the sensors will fall back to the factory default IP address. To avoid IP address conflicts in a multi-sensor system, connect to one sensor at a time and re-attempt the firmware upgrade.

## Data Types

The table below defines the data types and associated type identifiers used throughout this document. All values are transmitted in little endian format (least significant byte first) unless stated otherwise.

### Data Types

Type	Id	Description
8u	1	8-bit unsigned integer.
8s	2	8-bit signed integer.
16u	3	16-bit unsigned integer.
16s	4	16-bit signed integer.
32u	5	32-bit unsigned integer.
32s	6	32-bit signed integer.
64u	7	64-bit unsigned integer.
64s	8	64-bit signed integer.
byte	9	1 Byte.
char	10	8-bit ASCII-encoded character.
64f	11	64-bit floating point value.
32f	12	32-bit floating point value.



IP addresses are an exception to the little endian rule. The bytes in the address "a.b.c.d" will always be transmitted in the order a, b, c, d (big endian).

## Profile Sources

Profile data is always associated with a *profile source*. The profile source identifies the scope and nature of the laser profile information.

### Profile Sources

Profile Source	Id	Description
Main	0	Data from the Main sensor
Buddy	1	Data from the Buddy sensor
Combined	100	Combined data from the Main and Buddy sensor (for wide orientation)

## Status Codes

Each reply on the Discovery, Control, and Upgrade channels contains a status code indicating the result of the command. The following status codes are defined.

### Status Codes

Label	Value	Description
OK	1	Command succeeded.
Failed	0	Command failed.
Invalid State	-1000	Command is not valid in the current state.
Item Not Found	-999	A required item (e.g., file) was not found.
Invalid Command	-998	Command is not recognized.
Invalid Parameter	-997	One or more command parameters are incorrect.
Not Supported	-996	The operation is not supported.

## Command and Reply Formats

Commands and replies that are sent and received on the Control and Upgrade channels each begin with a common header.

### Command Header

Field	Type	Description
length	64s	Command size, in bytes.
id	64s	Command identifier.

### Reply Header

Field	Type	Description
length	64s	Reply size, in bytes.
id	64s	Reply identifier (same as command identifier, unless otherwise noted).
status	64s	Reply status.



Length fields added to the beginning of each message refer to the size of the entire message including the length field itself. For example, the value of the length field for a command that consists of only the header (no additional fields) would be 16.

## Result Format

Result messages that are received on the Data and Health channels have a common structure. Each result message has a flexible number of attributes in its header followed by a variable number of data blocks after the header. The structure of result messages is defined below.

### Result

Field	Type	Description
length	64s	Message length, in bytes.
id	64s	Message type identifier.
attributeCount	64s	Count of attributes in this message.
dataCount	64s	Count of data blocks in this message.
attributes[N]	64s	List of attributes specific to a particular message type.
descriptors[M]	Descriptor	List of data block descriptors (one per data block - format defined below).
blocks[M]	-	List of data blocks specific to a particular message type.

### Block Descriptor

Field	Type	Description
length0	64s	Length of block dimension 0.
length1	64s	Length of block dimension 1.
length2	64s	Length of block dimension 2.
type	Type	Data type of block elements. See <i>Data Types</i> (page 256).

Each data block is an array of primitive values with 1, 2, or 3 dimensions and is described by an accompanying descriptor. The first *length* field that contains a zero determines the dimensionality of the block. For example, the length 2 field will contain zero for a 2 dimensional block. Items in the highest numbered dimension are transmitted sequentially.

Specific result messages, described later in this chapter, are defined by identifying the attributes and data block formats necessary to express the message content.

## Discovery Commands

### Get Address

The Get Address command is used to discover Gocator sensors across subnets.

#### Command

Field	Type	Description
length	64s	Command size, in bytes.
id	64s	Command identifier (0x0001)
signature	64s	Magic number (0x0000504455494D4C).
identifier	64s	Device identifier (serial number) or zero to discover unknown devices.

#### Reply

Field	Type	Description
length	64s	Reply size, in bytes.
id	64s	Reply identifier (0x1001).
status	64s	Reply status.
signature	64s	Magic number (0x0000504455494D4C).
deviceld	64s	Device identifier.
useDhcp	64s	1 if network interface uses DHCP, 0 otherwise.
reserved[4]	byte	Reserved.
address[4]	byte	IP address.
reserved[4]	byte	Reserved.
mask[4]	byte	Subnet mask.
reserved[4]	byte	Reserved.
gateway[4]	byte	Gateway.

Field	Type	Description
reserved[4]	byte	Reserved.
reserved[4]	byte	Reserved.

## Set Address

The Set Address command modifies the network configuration of a Gocator sensor. On receiving the command, the Gocator will perform a reset. You should wait 30 seconds before re-connecting to the Gocator.

### Command

Field	Type	Description
length	64s	Command size, in bytes.
id	64s	Command identifier (0x0002).
signature	64s	Magic number (0x0000504455494D4C).
deviceld	64s	Device identifier (serial number).
useDhcp	64s	1 if network interface uses DHCP, 0 otherwise.
reserved[4]	byte	Reserved. Set to 0.
address[4]	byte	IP address.
reserved[4]	byte	Reserved. Set to 0.
mask[4]	byte	Subnet mask.
reserved[4]	byte	Reserved. Set to 0.
gateway[4]	byte	Gateway.
reserved[4]	byte	Reserved. Set to 0.
reserved[4]	byte	Reserved. Set to 0.

### Reply

Field	Type	Description
length	64s	Reply size – in bytes.
id	64s	Reply identifier (0x1002).
status	64s	Reply status.
signature	64s	Magic number (0x0000504455494D4C).
deviceld	64s	Device identifier.

## Upgrade Commands

### Get Protocol Version

The Get Protocol Version command reports the Upgrade protocol version of the connected sensor.

### Command

Field	Type	Description
length	64s	Command size – in bytes.
id	64s	Command identifier (0x0100).

### Reply

Field	Type	Description
length	64s	Reply size – in bytes.
id	64s	Reply identifier.
status	64s	Reply status.
majorVersion	64s	Major version.
minorVersion	64s	Minor version.

## Start Upgrade

The Start Upgrade command begins a firmware upgrade for the Main sensor and any Buddy sensors. All sensors will automatically reset 3 seconds after the upgrade process is complete.

### Command

Field	Type	Description
length	64s	Command size – in bytes.
id	64s	Command identifier (0x0000).
fileSize	64s	Upgrade file size – in bytes.
file[fileSize]	byte	Upgrade file.

### Command

Field	Type	Description
length	64s	Reply size – in bytes.
id	64s	Reply identifier.
status	64s	Reply status.

## Get Upgrade Status

The Get Upgrade Status command determines the progress of a firmware upgrade.

### Command

Field	Type	Description
length	64s	Command size – in bytes.
id	64s	Command identifier (0x0001).

### Reply

Field	Type	Description
length	64s	Reply size – in bytes.

Field	Type	Description
id	64s	Reply identifier.
status	64s	Reply status.
stage	64s	Current upgrade stage: -1 – Upgrade Failed 0 – Upgrade Completed 1 – Upgrade in Progress
progress	64s	Percentage completed – valid when stage is Upgrade in Progress.

## Get Upgrade Log

The Get Upgrade Log command can retrieve an upgrade log in the event of upgrade problems.

### Command

Field	Type	Description
length	64s	Command size – in bytes.
id	64s	Command identifier (0x0002).

### Reply

Field	Type	Description
length	64s	Reply size – in bytes.
id	64s	Reply identifier.
status	64s	Reply status.
fileSize	64s	Log file size – in bytes.
file[fileSize]	byte	Log file.

## Control Commands

### Get Protocol Version

The Get Protocol Version command reports the Control protocol version of the connected sensor.

### Command

Field	Type	Description
length	64s	Command size – in bytes.
id	64s	Command identifier (0x4511).

### Reply

Field	Type	Description
length	64s	Reply size – in bytes.
id	64s	Reply identifier.
status	64s	Reply status.

Field	Type	Description
majorVersion	64s	Major version.
minorVersion	64s	Minor version.

## Get System Info

The Get System Info command reports information for sensors that are visible in the system.

### Command

Field	Type	Description
length	64s	Command size – in bytes.
id	64s	Command identifier (0x4002).

### Reply

Field	Type	Description
length	64s	Reply size – in bytes.
id	64s	Reply identifier.
status	64s	Reply status.
deviceld	64s	Connected sensor device id (serial number).
firmwareVersion	64s	Connected sensor firmware version.
modelName[32]	char	Connected sensor model name (null-terminated).
role	64s	Connected sensor network role: 0 – Standalone 1 – Main (in a Buddy setup) 2 – Buddy
loginState	64s	Authenticated user: 0 – None 1 – Administrator 2 – Technician
systemState	64s	Current system state: 1 – Conflict 2 – Ready 3 – Running
calibrationType	64s	Current calibration state: 0 – Not calibrated 1 – Auto calibrated 2 – Manual calibrated
hasBuddy	64s	Current buddy assignment state: 0 – No Buddy assigned 1 – Buddy assigned
BuddyInfo	BuddyInfo	Assigned Buddy information (not present if hasBuddy is 0).
sensorCount	64s	Count of visible sensors.
sensorInfo[sensorCount]	SensorInfo	Sensor Information (see format below).

### *Buddy Info*

<b>Field</b>	<b>Type</b>	<b>Description</b>
deviceId	64s	Buddy device id.
state	64s	Sensor Buddy state: 0 - Connected 1 - Missing 2 - Error
modelName[32]	char	Sensor model name.
firmwareVersion	64s	Buddy firmware version.

### *SensorInfo*

<b>Field</b>	<b>Type</b>	<b>Description</b>
state	64s	Sensor state: 0 - Paired (not set for Main sensor) 1 - Available 2 - Unavailable
modelName[32]	char	Sensor model name (null-terminated).
firmwareVersion	64s	Sensor firmware version.

## Log In/Out

The Log In/Out command is used to log in or out of a sensor.

### *Command*

<b>Field</b>	<b>Type</b>	<b>Description</b>
length	64s	Command size - in bytes.
id	64s	Command identifier (0x4003).
userType	64s	User account: 0 - None (log out) 1 - Administrator 2 - Technician
password[64]	char	Password (null-terminated; required for log-in only).

### *Reply*

<b>Field</b>	<b>Type</b>	<b>Description</b>
length	64s	Reply size - in bytes.
id	64s	Reply identifier.
status	64s	Reply status.

## Change Password

The Change Password command is used to change log-in credentials for a user.

### Command

Field	Type	Description
id	64s	Command identifier (0x4004).
user type	64s	User account: 1 - Administrator 2 - Technician
password[64]	char	New password (null-terminated).

### Reply

Field	Type	Description
length	64s	Reply size - in bytes.
id	64s	Reply identifier.
status	64s	Reply status.

## Change Buddy

The Change Buddy command is used to assign or unassign a Buddy sensor.

### Command

Field	Type	Description
length	64s	Command size - in bytes.
id	64s	Command identifier (0x4005).
action	64s	Action to take: 0 - Unassign Buddy. 1 - Assign Buddy.
count	64s	Count of sensors affected by action (must be 1 at present).
deviceid[count]	64s	List of target sensors.

### Reply

Field	Type	Description
length	64s	Reply size - in bytes.
id	64s	Reply identifier.
status	64s	Reply status.

## Get File List

The Get File List command reports the list of available files on the connected sensor.

### Command

Field	Type	Description
length	64s	Command size - in bytes.
id	64s	Command identifier (0x101A).

Field	Type	Description
extension[64]	char	Null-terminated file extension filter, or empty: cfg – Configuration files rec – Record/Playback data files prof – Profile template files xml – XML file

#### Reply

Field	Type	Description
length	64s	Reply size – in bytes.
id	64s	Reply identifier.
status	64s	Reply status.
count	64s	Number of file names returned.
name[count][64]	char	List of file names.

## Copy File

The Copy File command copies a file from a source to a destination within the connected sensor. Copy a saved configuration to

"\_live.cfg" to make the configuration live. Copy a saved template to "\_live.prof" to make the template live.

#### Command

Field	Type	Description
length	64s	Command size – in bytes.
id	64s	Command identifier (0x101B).
source [64]	char	Source file name (null-terminated).
destination [64]	char	Destination file name (null-terminated).

#### Reply

Field	Type	Description
length	64s	Reply size – in bytes.
id	64s	Reply identifier.
status	64s	Reply status.

## Read File

Downloads a file from the connected sensor. Read the file "\_live.cfg" and "\_live.prof" to down the live configuration and template.

#### Command

Field	Type	Description
length	64s	Command size – in bytes.
id	64s	Command identifier (0x1007).
fileName[64]	char	File name (null-terminated).

### Reply

Field	Type	Description
length	64s	Reply size – in bytes.
id	64s	Reply identifier.
status	64s	Reply status.
fileSize	64s	File size – in bytes.
file[fileSize]	byte	File content.

## Write File

The Write File command uploads a file to the connected sensor. Write to "\_live.cfg" and "\_live.prof" to write the make the configuration and template files live. Except for writing to the live files, the file is permanently stored on the sensor.

### Command

Field	Type	Description
length	64s	Command size – in bytes.
id	64s	Command identifier (0x1006).
fileName[64]	char	File name (null-terminated).
fileSize	64s	File size – in bytes.
file[fileSize]	byte	File content.

### Reply

Field	Type	Description
length	64s	Reply size – in bytes.
id	64s	Reply identifier.
status	64s	Reply status.

## Delete File

The Delete File command removes a file from the connected sensor.

### Command

Field	Type	Description
length	64s	Command size – in bytes.
id	64s	Command identifier (0x1008).
fileName[64]	char	File name (null-terminated).
Field	Type	Description
fileSize	64s	File size – in bytes.
file[fileSize]	byte	File content.

### Reply

Field	Type	Description
length	64s	Reply size – in bytes.
id	64s	Reply identifier.
status	64s	Reply status.

## Get Default File

The Get Default File command gets the name of a default file that will be loaded at boot time. Default files can be defined for configuration, profile templates, and calibration (with different extensions).

### Command

Field	Type	Description
length	64s	Command size – in bytes.
id	64s	Command identifier (0x4100).
extension[64]	char	Null-terminated file extension: cfg – Configuration files rec – Record/Playback data files prof – Profile template files

### Reply

Field	Type	Description
length	64s	Reply size – in bytes.
id	64s	Reply identifier.
status	64s	Reply status.
fileName[64]	char	File name (null-terminated).

## Set Default File

The Set Default File command sets the name of a default file that will be loaded at boot time. Default files can be defined for configuration, calibration, and profile templates (differentiated by extension).

### Command

Field	Type	Description
length	64s	Command size – in bytes.
id	64s	Command identifier (0x4101).
fileName[64]	char	File name (null-terminated), including the extension. cfg – Configuration files rec – Record/Playback data files prof – Profile template files

### Reply

Field	Type	Description
length	64s	Reply size – in bytes.
id	64s	Reply identifier.
status	64s	Reply status.

## Get Loaded File

The Get Loaded File command returns the currently loaded (i.e., live) file name and modified status for a file type.

### Command

Field	Type	Description
length	64s	Command size – in bytes.
id	64s	Command identifier (0x4512).
extension[64]	char	Extension for the file type: cfg – Configuration files prof – Profile template files

### Reply

Field	Type	Description
length	64s	Reply size – in bytes.
id	64s	Reply identifier.
status	64s	Reply status.
fileName[64]	char	Name of the currently loaded file.
changed	64	Whether or not the currently loaded file has been changed (1: yes; 0: no).

## Get Mode

The Get Mode command reports the name of the current system mode.

### Command

Field	Type	Description
length	64s	Command size – in bytes.
id	64s	Command identifier (0x1005).

### Reply

Field	Type	Description
length	64s	Reply size – in bytes.
id	64s	Reply identifier.
status	64s	Reply status.
mode[16]	char	Mode name (null-terminated).

## Set Mode

The Set Mode command sets the name of the current system mode.

### Command

Field	Type	Description
length	64s	Command size – in bytes.
id	64s	Command identifier (0x1004).
mode[16]	char	Mode name (null-terminated).

### Reply

Field	Type	Description
length	64s	Reply size – in bytes.
id	64s	Reply identifier.
status	64s	Reply status.

## Get Time

This command retrieves the system clock, in microseconds. All devices in a system are synchronized with the system clock; this value can be used for diagnostic purposes, or used to synchronize the start time of the system.

### Command

Field	Type	Description
length	64s	Command size – in bytes.
id	64s	Command identifier (0x100A).

### Reply

Field	Type	Description
length	64s	Reply size – in bytes.
id	64s	Reply identifier (0x100A).
status	64s	Reply status.
time	64u	Current time, in microseconds.

## Get Encoder

This command retrieves the current system encoder value.

### Command

Field	Type	Description
length	64s	Command size – in bytes.
id	64s	Command identifier (0x101C).

### Reply

Field	Type	Description
length	64s	Reply size – in bytes.
id	64s	Reply identifier (0x101C).
status	64s	Reply status.
encoder	64s	Current encoder value, in ticks.

## Start

The Start command starts the sensor system (system enters the Running state).

### Command

Field	Type	Description
length	64s	Command size – in bytes.
id	64s	Command identifier (0x100D).
reserved	64s	Reserved field – set to 0.

### Reply

Field	Type	Description
length	64s	Reply size – in bytes.
id	64s	Reply identifier.
status	64s	Reply status.

## Scheduled Start

The scheduled start command starts the sensor system (system enters the Running state) at target time or encoder value (depending on the trigger mode).

The time and encoder targets value should be set by adding a delay to the time and/or encoder tick returned by the Get Time and Get Encoder commands. The delay should be set such that it covers the command response time of the Scheduled Start command.

### Command

Field	Type	Description
length	64s	Command size – in bytes.
id	64s	Command identifier (0x101D).
time target	64s	Specify start time target, in microseconds.
encoder target	64s	Specify start encoder target in ticks.

### Reply

Field	Type	Description
length	64s	Reply size – in bytes.
id	64s	Reply identifier (0x101D).
status	64s	Reply status.

## Stop

The Stop command stops the sensor system (system enters the Ready state).

### Command

Field	Type	Description
length	64s	Command size – in bytes.
id	64s	Command identifier (0x1001).

### Reply

Field	Type	Description
length	64s	Reply size – in bytes.
id	64s	Reply identifier.
status	64s	Reply status.

## Trigger

The Trigger command applies a software trigger to the system. The system must be configured to accept software triggers and must be in the Running State.

### Command

Field	Type	Description
length	64s	Command size – in bytes.
id	64s	Command identifier (0x4510).

### Reply

Field	Type	Description
length	64s	Reply size – in bytes.
id	64s	Reply identifier.
status	64s	Reply status.

## Scheduled Digital Output

The Scheduled Digital Output command schedules a digital output event. The digital output must be configured to accept software-scheduled commands and be in the Running state. See *Digital Outputs* (page 161) for information on setting up the digital output.

### Command

Field	Type	Description
length	64s	Command size – in bytes.
id	64s	Command identifier (0x4518).
index	64s	Index of the output (starts from 0)
target	64s	Specifies the time (us) or position (encoder ticks) of when the event should happen.  The target value is ignored if the Signal type in the Digital Output panel is not set to scheduled. The output will be triggered immediately. See <i>Digital Outputs</i> (page 161) for information on setting the Signal type.
value	64s	Specifies the target state: 0 – Set to low (continuous) 1 – Set to high (continuous) Ignored if output type is pulsed.

### Reply

Field	Type	Description
length	64s	Reply size – in bytes.
id	64s	Reply identifier.
status	64s	Reply status.

## Scheduled Analog Output

The Scheduled Analog Output command schedules an analog output event. The analog output must be configured to accept software-scheduled commands and be in the Running state. See *Analog Output* (page 164) for information on setting up the analog output.

### Command

Field	Type	Description
length	64s	Command size – in bytes.
id	64s	Command identifier (0x4519).
index	64s	Index of the output. Must be 0.
target	64s	Specifies the time (us) or position (encoder ticks) of when the event should happen. The target value is ignored if the Signal type in the Analog Output panel is not set to scheduled. The output will be triggered immediately. See <i>Analog Output</i> (page 164) for information on setting the Signal type.
value	64s	Output current (nano-amperes).

### Reply

Field	Type	Description
length	64s	Reply size – in bytes.
id	64s	Reply identifier.
status	64s	Reply status.



The analog output takes about 75 us to reach 90% of the target value for a maximum change, then roughly another 40 us to settle completely.

## Ping

The Ping command can be used to test the control connection. This command has no effect.

### Command

Field	Type	Description
length	64s	Command size – in bytes.
id	64s	Command identifier (0x100E).
reserved	64s	Reserved – set to 0.

### Reply

Field	Type	Description
length	64s	Reply size – in bytes.
id	64s	Reply identifier.
status	64s	Reply status.

## Reset

The Reset command reboots the Main sensor and any Buddy sensors. All sensors will automatically reset 3 seconds after the reply to this command is transmitted.

### Command

Field	Type	Description
length	64s	Command size – in bytes.
id	64s	Command identifier (0x4300).

### Reply

Field	Type	Description
length	64s	Reply size – in bytes.
id	64s	Reply identifier.
status	64s	Reply status.

## Backup

The Backup command creates a backup of all files stored on the connected sensor and downloads the backup to the client.

### Command

Field	Type	Description
length	64s	Command size – in bytes.
id	64s	Command identifier (0x1013).

### Reply

Field	Type	Description
length	64s	Reply size – in bytes.
id	64s	Reply identifier.
status	64s	Reply status.
fileSize	64s	Size of backup file – in bytes.
file[fileSize]	byte	Backup file content.

## Restore

The Restore command uploads a backup file to the connected sensor and then restores all sensor files from the backup.



The sensor must be reset or power-cycled before the restore operation can be completed.

### Command

Field	Type	Description
length	64s	Command size – in bytes.
id	64s	Command identifier (0x1014).
fileSize	64s	Size of backup file – in bytes.
file[fileSize]	byte	Backup file content.

### Reply

Field	Type	Description
length	64s	Reply size – in bytes.
id	64s	Reply identifier.
status	64s	Reply status.

## Restore Factory

The Restore Factory command restores the connected sensor to factory default settings. This command has no effect on connected Buddy sensors.

Note that the sensor must be reset or power-cycled before the factory restore operation can be completed.

### Command

Field	Type	Description
length	64s	Command size – in bytes.
id	64s	Command identifier (0x4301).
resetAddress	64s	Specifies whether network address should be restored to default: 0 – Do not reset address 1 – Reset address

### Reply

Field	Type	Description
length	64s	Reply size – in bytes.
id	64s	Reply identifier.
status	64s	Reply status.

## Get Connection Type

The Get Connection Type command returns to the set connection type.

### Command

Field	Type	Description
length	64s	Command size – in bytes.
id	64s	Command identifier (0x4515).

### Reply

Field	Type	Description
length	64s	Reply size – in bytes.
id	64s	Reply identifier.
status	64s	Reply status.
type	64s	Connection type (see below).

## Set Connection Type

The Set Connection Type command save the type of the master to the sensor's non-volatile storage.

### Command

Field	Type	Description
length	64s	Command size – in bytes.
id	64s	Command identifier (0x4514).
type	64s	Connection type: 0 – None 1 – Master 100 2 – Master 200 3 – Master 400 4 – Master 800 5 – Master 1200 6 – Master 2400

### Reply

Field	Type	Description
length	64s	Reply size – in bytes.
id	64s	Reply identifier.
status	64s	Reply status.

## Clear Calibration

The Clear calibration command deletes the calibration results.

### Command

Field	Type	Description
length	64s	Command size – in bytes.
id	64s	Command identifier (0x4102).

### Reply

Field	Type	Description
length	64s	Reply size – in bytes.
id	64s	Reply identifier.
status	64s	Reply status.

## Data Results

A Data Result message adheres to the general structure for result messages as defined in Result Format (see page 257).

A Data Result contains a variable number of blocks depending on the sources selected for Ethernet output. Each selected source contributes two data blocks (and accompanying data block descriptors): one block for attributes and one block for content such as video pixels or measurement results.

### Data Result Header

Field	Type	Description
length	64s	Message length – in bytes.
id	64s	Message id (1).
attributeCount	64s	Count of attributes in this message header (7).
dataCount	64s	Count of data blocks in this message (variable).
reserved	64s	Reserved for internal use.
timestamp	64s	Timestamp (us).
encoder	64s	Encoder value (ticks).
frameCount	64s	Frame count.
digitalInputs	64s	Digital input states.
encoderIndex	64s	Encoder value when the last index is triggered.
reserved	64s	Reserved for internal use.
descriptors[dataCount]	Descriptor	List of data block descriptors.
data[dataCount]	-	List of data blocks.

The formats of the data blocks contributed from specific data sources are described in the following sections.

## Video

### Video Attributes

Field	Type	Description
dataType	64s	Data type (0x00).
source	64s	Video source.
camera index	64s	Camera index 0 - Front 1 - Back
exposure index	64s	Exposure step index
exposure	64s	Exposure (us).
reserved[N]	64s	A variable number of additional attributes may be included.

### Video Data

Field	Type	Description
pixels[height][width]	Byte	Image pixels (dimensions and data type given by block descriptor).

## Profile

### Profile Attributes

Field	Type	Description
dataType	64s	Data type: 0x01 – Resampled profile 0x02 – Raw profile
source	64s	Profile source.
xResolution	64s	X resolution (nm).
zResolution	64s	Z resolution (nm).
xOffset	64s	X offset (nm).
zOffset	64s	Z offset (nm).
exposure	64s	Exposure (ns). Set to zero if multiple exposure mode is used.
reserved[N]	64s	A variable number of additional attributes may be included.

### Profile Data (resampled)

Field	Type	Description
ranges[rangeCount]	16s	Range values (unit is Z resolution, 0x8000 represents null range). Dimensions and data type given by block descriptor Z system coordinate = zOffset + zResolution * ranges[index] X system coordinate = xOffset + xResolution * index.

### Profile Data (raw)

Field	Type	Description
ranges[rangeCount][2]	16s	X values and range values (units are X resolution and Z resolution respectively. 0x8000 represents NULL point). Dimensions and data type given by block descriptor. X system coordinate = xOffset + xResolution * ranges[rangeCount][0] Z system coordinate = zOffset + zResolution * ranges[rangeCount][1]

## Profile Intensity

### Profile Intensity Attributes

Field	Type	Description
dataType	64s	Data type: 0x7 – Resampled profile intensity values 0x8 – Raw profile.intensity values
source	64s	Profile source.
reserved[N]	64s	A variable number of additional attributes may be included.

### Profile Intensity Data (resampled or raw)

Field	Type	Description
intensityValues[rangeCount]	8u	Array of profile intensity values. Items in the array are arranged in the same order as items in the part profile array. A value of 0 indicates no spot. Dimensions and data type given by block descriptor.

## Part Profile

### Part Profile Attributes

Field	Type	Description
dataType	64s	Data type (0x03).
source	64s	Profile source.
xResolution	64s	X resolution (nm).
yResolution	64s	Y resolution (nm).
zResolution	64s	Z resolution (nm).
xOffset	64s	X offset (nm).
yOffset	64s	Y offset (nm).
zOffset	64s	Z offset (nm).
reserved[N]	64s	A variable number of additional attributes may be included.

### Part Profile Data

Field	Type	Description
ranges[partLength] [partWidth]	16s	Range values (unit is Z resolution, 0x8000 represents null range). Dimensions and data type given by block descriptor. $Z \text{ system coordinate} = zOffset + zResolution * ranges[indexY][indexX]$ $X \text{ system coordinate} = xOffset + xResolution * indexX$ $Y \text{ system coordinate} = yOffset + yResolution * indexY$

## Part Intensity

### Part Intensity Attributes

Field	Type	Description
dataType	64s	Data type (0x09).
source	64s	Profile source.
xOffset	64s	X offset (nm).
yOffset	64s	Y offset (nm).
xResolution	64s	X resolution (nm).
yResolution	64s	Y resolution (nm).
reserved[N]	64s	A variable number of additional attributes may be included.

### Part Intensity Data

Field	Type	Description
intensityValues[partLength] [partWidth]	8u	Array of profile intensity values. Items in the array are arranged in the same order as items in the part profile array. A value of 0 indicates no spot. Dimensions and data type given by block descriptor.

## Alignment Calibration

### *Alignment Calibration Attributes*

Field	Type	Description
dataType	64s	Data type (0x04).
reserved{N}	64s	A variable number of additional attributes may be included.

### *Alignment Calibration Data*

Field	Type	Description
status	64s	Calibration result.

## Travel Calibration

### *Travel Calibration Attributes*

Field	Type	Description
dataType	64s	Data type (0x05).
reserved{N}	64s	A variable number of additional attributes may be included.

### *Travel Calibration Data*

Field	Type	Description
status	64s	Calibration result.

## Exposure Calibration

### *Exposure Calibration Attributes*

Field	Type	Description
dataType	64s	Data type (0x06).
reserved{N}	64s	A variable number of additional attributes may be included.

### *Exposure Calibration Data*

Field	Type	Description
status	64s	Calibration result.
exposure	64s	Calibrated exposure (ns).

## Measurement

### *Measurement Attributes*

Field	Type	Description
dataType	64s	Data type (0x10, 0x11, 0x12, or 0x20).
measurementType	64s	Measurement type: 0x00 – Width (um) 0x01 – Height (um)

Field	Type	Description
		0x02 – Distance (um)
		0x03 – Center X (um)
		0x04 – Center Z (um)
		0x05 – Position X (um)
		0x06 – Position Z (um)
		0x10 – Intersect X (um)
		0x11 – Intersect Z (um)
		0x12 – Intersect Angle (0.001 degree)
		0x13 – Angle X (0.001 degree)
		0x20 – Intersect Area (0.001 mm <sup>2</sup> )
		0x21 – Box Area (0.001 mm <sup>2</sup> )
		0x23 – Difference Area (0.001 mm <sup>2</sup> )
		0x24 – Difference Peak (um)
		0x25 - Gap (um)
		0x26 - Flush (um)
		0x27 – Circle Radius (um)
		0x28 – Circle X (um)
		0x29 – Circle Z (um)
		0x2A – Line Standard Deviation (um)
		0x2B – Line Error Min (um)
		0x2C – Line Error Max (um)
		0x2D – Line Percentile (um)
		0x2E – Groove X (um)
		0x2F – Groove Z (um)
		0x31 – Groove Width (um)
		0x37 - Groove Depth (um)
		0x33 – Strip Width (um)
		0x34 – Strip Height (um)
		0x35 – Strip X (um)
		0x36 – Strip Z (um)
		0x40 – Area (0.001 mm <sup>2</sup> )
		0x41 – Volume (0.001 mm <sup>3</sup> )
		0x42 – Height (um)
		0x43 – Centroid X (um)
		0x44 – Centroid Y (um)
		0x45 – Centroid Z (um)
		0x46 – Ellipse Major (um)
		0x47 – Ellipse Minor (um)
		0x48 – Ellipse Angle (0.001 degree)
		0x49 – Ellipse Ratio
		0x4A – Bounding Box X (um)
		0x4B – Bounding Box Y (um)
		0x4C – Bounding Box Width (um)
		0x4D – Bounding Box Length (um)

Field	Type	Description
		0x4E – Hole X (um)
		0x4F – Hole Y (um)
		0x50 – Hole Z (um)
		0x51 – Hole Radius (um)
		0x52 – Stud Tip X (um)
		0x53 – Stud Tip Y (um)
		0x54 – Stud Tip Z (um)
		0x55 – Stud Base X (um)
		0x56 – Stud Base Y (um)
		0x57 – Stud Base Z (um)
		0x58 – Stud Radius (um)
		0x59 – Opening X (um)
		0x5A – Opening Y (um)
		0x5B – Opening Z (um)
		0x5C – Opening Width (um)
		0x5D – Opening Length (um)
		0x5E – Opening Angle (0.001 degree)
		0x5F – Position X (um)
		0x60 – Position Y (um)
		0x61 – Position Z (um)
		0x62 – Plane X Angle (0.001 degree)
		0x63 – Plane Y Angle (0.001 degree)
		0x64 – Plane Z Offset (um)
		0x65 – Surface Texture Roughness (um)
		0x66 – Surface Texture Invalid Count (percentage x 1000)
		0x30 – Script (script-specific)
id	64s	Unique id of the measurement – as defined in the configuration.
reserved{N}	64s	A variable number of additional attributes may be included.

#### Measurement Data

Field	Type	Description
value	64s	Result value.
decision	64s	Result decision: 0 – Fail 1 – Pass

## Health Results

A Health Result message adheres to the general structure for result messages as defined in Result Format (see page 257).

A Health Result contains a single data block for health *indicators*. Each indicator reports the current status of some aspect of the sensor system, such as CPU usage or network throughput.

### *Health Result Header*

<b>Field</b>	<b>Type</b>	<b>Description</b>
length	64s	Message length, in bytes.
id	64s	Message id (1000).
attributeCount	64s	Count of attributes in this message header (1).
dataCount	64s	Count of data blocks in this message (1).
deviceId	64s	Sensor device id.
descriptors[dataCount]	Descriptor	List of data block descriptors.
data[dataCount]	-	List of data blocks.

The health data block contains a 2 dimensional array of indicator data. Each row in the array has the following format:

### *Health Indicator Format*

<b>Field</b>	<b>Type</b>	<b>Description</b>
id	64s	Indicator identifier (indicators are defined below).
instance	64s	Indicator instance.
value	64s	Indicator value.

The following health indicators are defined for Gocator sensor systems:

### *Health Indicators*

<b>Indicator</b>	<b>Id</b>	<b>Instance</b>	<b>Value</b>
Encoder Value	1003	-	Current system encoder tick.
Encoder Index	1004	-	Current system encoder index.
Encoder Frequency	1005	-	Current system encoder frequency (ticks/s).
Firmware Version	2000	-	Firmware application version.
FireSync Version	2001	-	Firmware FireSync version.
Temperature	2002	-	Internal temperature (degrees Celsius).
Memory Used	2003	-	Amount of memory currently used (bytes).
Memory Capacity	2004	-	Total amount of memory available (bytes).
Storage Used	2005	-	Amount of non-volatile storage used (bytes).
Storage Capacity	2006	-	Total amount of non-volatile storage available (bytes).
CPU Used	2007	-	CPU usage (percentage of maximum).
Net Out Used	2008	-	Current outbound network throughput (bytes/s).
Net Out Capacity	2009	-	Total available outbound network throughput (bytes/s).
State	2010	-	Current system state.
Camera Errors	2011	-	Number of camera frame errors encountered.

<b>Indicator</b>	<b>Id</b>	<b>Instance</b>	<b>Value</b>
Camera Drops	2012	-	Number of camera frames dropped.
Processing Drops	2015	-	Number of messages dropped before data processing.
Ethernet Drops	2016	-	Number of messages generated but not sent.
Uptime	2017	-	Time elapsed since boot-up or reset (seconds).
Speed	2018	-	Current speed (Hz).
Trigger Drops	2019	-	Number of dropped triggers.
Digital Output Drops	2020	Output index	Number of dropped digital outputs.
Analog Output Drops	2021	Output Index	Number of dropped analog outputs.
Serial Output Drops	2022	Output index	Number of dropped serial outputs.
Laser Temperature	2023		Laser temperature (degrees Celsius). Only available on sensors equipped with 3B-N laser.
Digital Inputs	2024		Current status of digital input
Camera Frame Count	2025		Number of camera frames
Camera Search Count	2026		Number of frames where laser has lost track when tracking window is used.
Laser Temperature	2027		Laser temperature. Only available on sensors equipped with laser temperature regulation.
Speed (thousandth)	2028	-	Current sampling rate (milli-Hz).
Valid Frame Count	20000	-	Number of frames with valid profile data.
Invalid Frame Count	20001	-	Number of frames without valid profile data.
Digital Output Pass (port 0)	20002	Output index	Number of pass digital output pulses.
Digital Output Fail (port 0)	20003	Output Index	Number of fail digital output pulses.
Digital Output Pass (port 1)	20004	Output index	Number of pass digital output pulses.
Digital Output Fail (port 1)	20005	Output Index	Number of fail digital output pulses.
Valid Spot Count	20006	-	Number of valid spots that are detected
Processing Latency	20007	-	Last delay from camera exposure to when results can be scheduled to Rich I/O.
Max Processing Latency	20008	-	Maximum delay from camera exposure to when results can be scheduled to Rich I/O. Reset on start.
Max Spot Count	20009	-	Maximum number of spots that can be detected.
X Fixturing Invalid Count	20010	-	Number of frames with x fixturing invalid.
Z Fixturing Invalid Count	20011	-	Number of frames with z fixturing invalid.
Replay Position	20016	-	Replay frame position
Replay Frame Count	20017	-	Number of frames in buffer

<b>Indicator</b>	<b>Id</b>	<b>Instance</b>	<b>Value</b>
Measurement	30000	Measurement id	Measurement value.
Measurement Pass	30001	Measurement id	Number of pass decisions.
Measurement Fail	30002	Measurement id	Number of fail decisions.
Measurement Minimum	30003	Measurement id	Minimum measurement value.
Measurement Maximum	30004	Measurement id	Maximum measurement value.
Measurement Average	30005	Measurement id	Average measurement value.
Measurement Stddev	30006	Measurement id	Standard deviation of measurement value.
Measurement Invalid Count	30007	Measurement id	Number of invalid values
Part Count	40002		Number of parts detected in Whole Part mode.

Additional undocumented indicator values may be included in addition to the indicators defined above.

# Modbus TCP Protocol

Modbus TCP is designed to allow industrial equipment such as Programmable Logic Controllers (PLC), sensors, and physical input/output devices to communicate over an Ethernet network.

Modbus TCP embeds a Modbus frame into a TCP frame in a simple manner. This is a connection-oriented transaction, and every query expects a response.

This section describes the Modbus TCP commands and data formats. Modbus TCP communication enables the client to:

- Switch to a different active configuration.
- Calibrate and run sensors.
- Receive sensor states, stamps, and measurement results.

Modbus TCP is enabled in the Output panel. For more information, see *Ethernet Output* (page 157).

If buffering is enabled with the Modbus protocol, the PLC must read the Buffer Advance output register (see page 288) to advance the queue before reading the measurement results.

## Concepts

A PLC sends a command to start each Gocator. The PLC then periodically queries each Gocator for its latest measurement results. In Modbus terminology, the PLC is a Modbus Client. Each Gocator is a Modbus Server which serves the results to the PLC.

The Modbus TCP protocol uses TCP for connection and messaging. The PLC makes a TCP connection to the Gocator on port 502. Control and data messages are communicated on this TCP connection. Up to four clients can be connected to the Gocator simultaneously. A connection will be closed after 10 minutes of inactivity.

## Messages

All Modbus TCP messages consist of an MBAP header (Modbus Application Protocol), a function code, and a data payload.

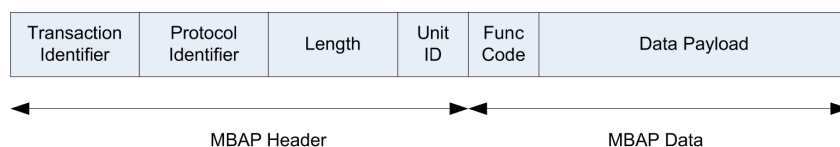

The MBAP header contains the following fields:

### Modbus Application Protocol Header

Field	Length (Bytes)	Description
Transaction ID	2	Used for transaction pairing. The Modbus Client sets the value and the Server (Gocator) copies the value into its responses.
Protocol ID	1	Always set to 0.
Length	1	Byte count of the rest of the message, including the Unit identifier

Field	Length (Bytes)	Description
		and data fields.
Unit ID	1	Used for intra-system routing purpose. The Modbus Client sets the value and the Server (Gocator) copies the value into its responses.

Modbus Application Protocol Specification describes the standard function codes in detail. Gocator supports the following function codes:

#### *Modbus Function Code*

Function Code	Name	Data Size (bits)	Description
3	Read Holding Registers	16	Read multiple data values from the sensor.
4	Read Input Registers	16	Read multiple data values from the sensor.
6	Write Single Register	16	Send a command or parameter to the sensor.
16	Write Multiple Registers	16	Send a command and parameters to the sensor.

The data payload contains the registers that can be accessed by Modbus TCP messages. If a message accesses registers that are invalid, a reply with an exception is returned. Modbus Application Protocol Specification defines the exceptions and describes the data payload format for each function code.

The Gocator data includes 16-bit, 32-bit, and 64-bit data. All data are sent in big endian format, with the 32-bit and 64-bit data spread out into two and four consecutive registers.

#### *32-bit Data Format*

Register	Name	Bit Position
0	32-bit Word 1	31 .. 16
1	32-bit Word 0	15 .. 0

#### *64-bit Data Format*

Register	Name	Bit Position
0	64-bit Word 3	63 .. 48
1	64-bit Word 2	47 .. 32
2	64-bit Word 1	31 .. 16
3	64-bit Word 0	15 .. 0

## Registers

Modbus registers are 16 bits wide and are either control registers or output registers.

Control registers are used to control the sensor states (e.g., start, stop, or calibrate a sensor), and the output registers report the sensor states, stamps, and measurement values and decisions. You can read multiple output registers using a single Read Holding Registers or a single Read Input Registers

command. Likewise, you can control the state of the sensor using a single Write Multiple Register command.

Control registers are write-only, and output registers are read-only.

#### Register Map Overview

Register Address	Name	Read/Write	Description
0 - 124	Control Registers	WO	Registers for Modbus commands. See <i>Control Registers</i> (below) for detailed descriptions.
300 -371	Sensor States	RO	Report sensor states. See <i>Output Registers</i> (next page) for detailed descriptions.
900 - 999	Stamps	RO	Return stamps associated with each profile. See <i>Output Registers</i> (next page) for detailed descriptions.
1000 - 1060	Measurements & Decisions	RO	20 Measurement and decision pairs. See <i>Measurement Registers</i> (page 289) for detailed descriptions.

## Control Registers

Control registers are used to operate the sensor. Register 0 stores the command to be executed. Registers 1 to 21 contain parameters for the commands. The Gocator executes a command when the value in Register 0 is changed. To set the parameters before a command is executed, you should set up the parameters and the command using a single Multiple Write register command.

#### Control Register Map

Register Address	Name	Read/Write	Description
0	Command Register	WO	Command register. See the Command Register Values table below for more information.
1 – 21	Configuration or Calibration Filename	WO	<p>Null-terminated filename.</p> <p>Each 16-bit register holds a single character.</p> <p>Only used for Load Configuration Command.</p> <p>Specifies the complete filename, including the file extension ".cfg" or ".set": e.g., "test.cfg" (must be null terminated).</p> <p>If you specify a file ending with the ".cfg" extension, only a configuration will be loaded, unless you are switching from a configuration whose calibration was performed with <b>Source</b> set to <b>Current Configuration</b> in the <b>Layout</b> panel (see page 79 for more details) to a configuration that uses global transformations. In the latter case, global transformations will also be loaded.</p> <p>If you specify a file ending with the ".set" extension, a configuration, the transformations that were</p>

Register Address	Name	Read/Write	Description
			associated with it by performing calibration using <b>Current Configuration</b> , and a template (if in profile mode and a template has been registered) will be loaded.

The values used for the Command Register are described below.

#### Command Register Values

Value	Name	Description
0	Stop running	Stop the sensor. No effect if sensor is already stopped.
1	Start Running	Start the sensor. No effect if sensor is already started.
2	Alignment Calibrate	Start the alignment calibration process. State register 301 will be set to 1 (busy) until the calibration process is complete.
3	Travel Calibrate	Start the travel calibration process. State register 301 will be set to 1 (busy) until the calibration process is complete.
4	Clear Calibration	Clear the calibration.
5	Load Configuration	Activate a configuration file. Registers 1 - 21 specify the filename.

## Output Registers

Output registers are used to output states, stamps, and measurement results. Each register address holds a 16-bit data value.

State reports the current sensor state.

#### State Register Map

Register Address	Name	Data Size (bit)	Description
300	Stopped / Running	16	Sensor State: 0 - Stopped 1 - Running
301	Busy	16	Busy State: 0 - Not busy 1 - Busy Registers 302 to 363 below are only valid when the Busy State is not Busy
302	Calibration State	16	Current Calibration State: 0 - Not calibrated 1 - Calibrated
303 – 306	Encoder Value	64	Current Encoder value (ticks).
307 – 310	Time	64	Current time (us).
311	Configuration File Length	16	Number of characters in the current configuration

Register Address	Name	Data Size (bit)	Description
			file name.
312 – 371	Live Configuration Name	16 bits for each character	Current Configuration Name. Name of currently loaded config file. Does not include the extension. Each 16-bit register contains a single character.

Stamps contain trigger timing information used for synchronizing a PLC's actions. A PLC can also use this information to match up data from multiple Gocator sensors.

In Profile mode, the stamps are updated after each profile is processed. In Part mode, the stamps are updated after each discrete part has been processed.

#### Stamp Register Map

Register Address	Name	Data Size (bit)	Description
976	Buffer Advance	16	If buffering is enabled this address must be read by the PLC Modbus client first to advance the buffer. After the buffer advance read operation, the Modbus client can read the updated Measurements & Decisions in addresses 1000-1060.
977	Buffer Counter	16	Number of buffered messages currently in the queue.
978	Buffer Overflow	16	Buffer Overflow Indicator: 0 - No overflow 1 - Overflow
979	Inputs	8	Digital input state.
980 – 983	Encoder Index	64	Encoder value when the index is last triggered.
984 – 985	Exposure	32	Exposure (us).
986 – 987	Temperature	32	Sensor temperature (mC).
988 – 991	Encoder Value	64	Encoder value (ticks).
992 – 995	Timestamp	64	Time (us).
996 – 999	Frame Counter	64	Frame counter.

## Measurement Registers

Measurement results are reported in pairs of values and decisions. Measurement values are 32 bits wide and decisions are 8 bits wide.

The measurement ID defines the register address of each pair. The register address of the first word can be calculated as  $(1000 + 3 * ID)$ . For example, a measurement with ID set to 4 can be read from registers 1012 (high word) and, 1013 (low word), and the decision at 1015.

In Profile mode, the measurement results are updated after each profile is processed. In Whole Part mode, the measurement results are updated after each discrete part has been processed.

*Measurement Register Map*

<b>Register Address</b>	<b>Name</b>	<b>Data Size (bits)</b>	<b>Description</b>
1000 – 1001	Measurement ID 0 Value	32	Measurement ID 0 Value
1002	Measurement ID 0 Decision	8	Measurement ID 0 Decision
1003 – 1004	Measurement ID 1 Value	32	Measurement ID 1 Value
1005	Measurement ID 1 Decision	8	Measurement ID 1 Decision
...	...	...	...

# EtherNet/IP Protocol

EtherNet/IP is an industrial protocol that allows bidirectional data transfer with PLCs. It encapsulates the object-oriented Common Industrial Protocol (CIP).

This section describes the EtherNet/IP messages and data formats. EtherNet/IP communication enables the client to:

- Switch to a different active configuration.
- Calibrate and run sensors.
- Receive sensor states, stamps, and measurement results.

EtherNet/IP is enabled in the **Output** panel. For more information, see *Ethernet Output* (page 157).

## Concepts

To EtherNet/IP-enabled devices on the network, the sensor information is seen as a collection of objects, which have attributes that can be queried. For example, an "assembly object" is a type of object with a data attribute that can be accessed with the GetAttribute and SetAttribute commands. The Gocator uses assembly objects to take commands and provide sensor state and measurement values.

The PLC sends a command to start a Gocator. The PLC then periodically queries the attributes of the assembly objects for its latest measurement results. In EtherNet/IP terminology, the PLC is a scanner and the Gocator is an adapter.

The Gocator supports unconnected or connected explicit messaging (with TCP). Implicit I/O messaging is not supported.

The default EtherNet/IP ports are used. Port 44818 is used for TCP connections and UDP queries (e.g., list Identity requests). Port 2222 for UDP I/O Messaging is not supported.

## Basic Object

### Identity Object (Class 0x01)

Attribute	Name	Type	Value	Description	Access
1	Vendor ID	UINT	1256	ODVA Provided Vendor ID	Get
2	Device Type	UINT	43	Device Type	Get
3	Product Code	UINT	2000	Product Code	Get
4	Revision	USINT USINT	x.x	Byte 0 - Major Revision Byte 1 - Minor Revision	Get
6	Serial number	UDINT	32-bit value	Sensor serial number.	Get
7	Product Name	SHORT STRING	"Gocator"	Gocator Product Name	Get
		32			

## TCP/IP Object (Class 0xF5)

The TCP/IP Object contains read-only network configuration attributes such as IP Address. TCP/IP configuration via Ethernet/IP is not supported. See Volume 2, Chapter 5-3 of the CIP Specification for a complete listing of TCP/IP object attributes.

Attribute	Name	Type	Value	Description	Access
1	Status	UDINT	0	TCP interface status	Get
2	Configuration Capability	UINT	0		Get
3	Configuration Control	UINT	0	Product Code	Get
4	Physical Link Object	Structure (See description)		See 5.3.3.2.4 of CIP Specification Volume 2: Path size (UINT) Path (Padded EPATH)	Get
5	Interface Configuration	Structure (See description)		See 5.3.3.2.5 of CIP Specification Volume 2" IP Address (UDINT) Network Mask (UDINT), Gateway Address (UDINT) Name Server (UDINT) Secondary Name (UDINT) Domain Name (UDINT)	Get

## Ethernet Link Object (Class 0xF6)

The Ethernet Link Object contains read-only attributes such as MAC Address (Attribute 3). See Volume 2, Chapter 5-4 of the CIP Specification for a complete listing of Ethernet Link object attributes.

Attribute	Name	Type	Value	Description	Access
1	Interface Speed	UDINT	100 for Gocator 2000, 1000 for Gocator 2300	Ethernet interface data rate (mbps)	Get
2	Interface Flags	UDINT		See 5.4.3.2.1 of CIP Specification Volume 2: Bit 0: Link Status 0 - Inactive 1 - Active Bit 1: Duplex 0 - Half Duplex 1 - Full Duplex	Get
3	Physical Address	Array of 6 USINTs		MAC Address (for example: 00 16 20 00 2E 42)	Get

## Assembly Object (Class 0x04)

The Gocator Ethernet/IP object model includes the following assembly objects: Command, Sensor State, Sample State, and Extended Sample State.

All assembly object instances are static. Data in a data byte array in an assembly object are stored in the big endian format.

### Command Assembly

The command assembly object is used to start, stop, calibrate, and switch configuration on the sensor.

#### *Command Assembly*

Information	Value
Class	0x4
Instance	0x310
Number of Attributes	3
Length	32 bytes
Supported Service	0x10 (Write Single Attribute)

Attributes 1 and 2 are not implemented, as they are not required for the static assembly object.

#### *Attribute 3*

Attribute	Name	Type	Value	Description	Access
3	Command	Byte Array	See Below	Commands parameters Byte 0 - Command. See table below for specification of the values. Byte 1-31 - Used for load configuration command	Get, Set

#### *Command Definitions*

Value	Name	Description
0	Stop running	Stop the sensor. No action if the sensor is already stopped
1	Start Running	Start the sensor. No action if the sensor is already started.
2	Alignment Calibrate	Start the calibration process. Byte 1 of the Sensor State Assembly will be set to 1 (busy) until the calibration process is complete, then back to zero.
3	Travel Calibrate	Start the travel calibration process. Byte 1 of the Sensor State Assembly will be set to 1 (busy) until the calibration process is complete, then back to zero
4	Clear Calibration	Clear the calibration
5	Load Configuration	Load a configuration file. Bytes 1 - 31 for the filename: one ASCII character per byte. File name must be NULL terminated. The extension ".cfg" or ".set" should be included. If you specify a file ending with the ".cfg" extension, only a configuration will be loaded, unless you are switching from a configuration whose

Value	Name	Description
		calibration was performed with Source set to Current Configuration in the Layout panel (see <i>Transformation Sources</i> (page 79) for more details) to a configuration that uses global transformations. In the latter case, global transformations will also be loaded. If you specify a file ending with the ".set" extension, a configuration, the transformations that were associated with it by performing calibration using Current Configuration, and a template (if in profile mode and a template has been registered) will be loaded.

## Sensor State Assembly

The sensor state assembly object contains the sensor's states, such as the current sensor temperature, frame count, and encoder values.

### Sensor State Assembly

Information	Value
Class	0x4
Instance	0x320
Number of Attributes	3
Length	100 bytes
Supported Service	0x0E (Get Single Attribute)

Attributes 1 and 2 are not implemented, as they are not required for the static assembly object.

### Attribute 3

Attribute	Name	Type	Value	Description	Access
3	Command	Byte Array		Sensor state information. See below for more details	Get

### Sensor State Information

Byte	Name	Description
0	Sensor's state	Sensor state: 0 - Ready 1 - Running
1	Command in progress	Command busy status: 0 - Not busy 1 - Busy performing the last command
2	Calibration state	Calibration status: 0 - Not calibrated 1 - Calibrated The value is only valid when the command in progress is set to 0.
3-10	Encoder	Current encoder position (64-bit signed integer)
11-18	Time	Current time (64-bit unsigned integer)

Byte	Name	Description
19	Current Configuration Filename Length	Number of characters in the current configuration filename. (e.g., 8 for "myconfig"). The length does NOT include the .cfg extension.
20-43	Current Configuration Filename	Name of currently loaded config file, does not include the ".cfg" extension. Each byte contains a single character (valid when byte 1 = 0).
44 - 99	Reserved	Reserved bytes

## Sample State Assembly

The sample state object contains measurements and their associated stamp information.

### Sample State Assembly

Information	Value
Class	0x4
Instance	0x321
Number of Attributes	3
Length	180 bytes
Supported Service	0x0E (Get Single Attribute)

### Attribute 3

Attribute	Name	Type	Value	Description	Access
3	Command	Byte Array		Sample state information. See below for more details	Get

### Sample State Information

Byte	Name	Description
0-1	Inputs	Digital input state
2-9	Z Index Position	Encoder position at time of last index pulse (64-bit signed integer)
10-13	Exposure	Laser exposure in us
14-17	Temperature	Sensor temperature in degrees celsius * 1000
18-25	Position	Encoder position 64-bit signed integer)
26-33	Time	Time (64-bit unsigned integer)
34-41	Frame Counter	Frame counter (64-bit unsigned integer)
42	Buffer Counter	Number of buffered messages currently in the queue.
43	Buffer Overflow	Buffer Overflow Indicator: 0 - No overflow 1 - Overflow

Byte	Name	Description
44 - 79	Reserved	Reserved bytes
80-83	Measurement 0	Measurement ID 0 Value
84	Decision 0	Measurement ID 0 Decision
85-88	Measurement 1	Measurement ID 1 Value
89	Decision 1	Measurement ID 1 Decision
...	...	
175-178	Measurement 19	Measurement ID 19 Value
179	Decision 19	Measurement ID 19 Decision

Measurement results are reported in pairs of values and decisions. Measurement values are 32 bits wide and decisions are 8 bits wide.

The measurement ID defines the byte position of each pair within the state information. The position of the first word can be calculated as  $(80 + 5 * ID)$ . For example, a measurement with ID set to 4 can be read from byte 100 (high word) to 103 (low word) and the decision at 104.

In Profile mode, the measurement results are updated after each profile is processed. In Whole Part mode, the measurement results are updated after each discrete part has been processed. If buffering is enabled in the Ethernet Output panel (see page 157), reading the Sample State Assembly Object automatically advances the buffer.

## Extended Sample State Assembly

The extended sample state object contains measurements and their associated stamp information.

### *Extended Sample State Assembly*

Information	Value
Class	0x4
Instance	0x322
Number of Attributes	3
Length	380 bytes
Supported Service	0x0E (Get Single Attribute)

### *Extended Sample State Information*

Byte	Name	Description
0-1	Inputs	Digital input state
2-9	Z Index Position	Encoder position at time of last index pulse (64-bit signed integer)
10-13	Exposure	Laser exposure in us
14-17	Temperature	Sensor temperature in degrees Celsius * 1000
18-25	Position	Encoder position 64-bit signed integer)
26-33	Time	Time (64-bit unsigned integer)

Byte	Name	Description
34-41	Frame Counter	Frame counter (64-bit unsigned integer)
42	Buffer Counter	Number of buffered messages currently in the queue.
43	Buffer Overflow	Buffer Overflow Indicator: 0 - No overflow 1 - Overflow
44 - 79	Reserved	Reserved bytes
80-83	Measurement 0	Measurement ID 0 Value
84	Decision 0	Measurement ID 0 Decision
85-88	Measurement 1	Measurement ID 1 Value
89	Decision 1	Measurement ID 1 Decision
...	...	
375-378	Measurement 59	Measurement ID 59 Value
379	Decision 59	Measurement ID 59 Decision

Measurement results are reported in pairs of values and decisions. Measurement values are 32 bits wide and decisions are 8 bits wide.

The measurement ID defines the byte position of each pair within the state information. The position of the first word can be calculated as  $(80 + 5 * ID)$ . For example, a measurement with ID set to 4 can be read from byte 100 (high word) to 103 (low word) and the decision at 104.

In Profile mode, the measurement results are updated after each profile is processed. In Whole Part mode, the measurement results are updated after each discrete part has been processed. If buffering is enabled in the Ethernet Output panel (See *Ethernet Output* (page 157)), reading the Extended Sample State Assembly Object automatically advances the buffer.

# ASCII Protocol

This section describes the ASCII protocol available over the Ethernet and serial outputs. The protocol communicates using ASCII strings. The output result format from the sensor is user-configurable.

## Ethernet Communication

Gocator's Ethernet communication is bidirectional. Measurement results are sent on the Ethernet output in one of two modes: Polling or Asynchronous. The ASCII protocol over Ethernet enables the client to:

- Switch to a different active configuration.
- Calibrate, run, and trigger sensors.
- Receive sensor states, health indicators, stamps, and measurement results

As with the Gocator Protocol (see page 253), there are separate channels for Control, Data, and Health messages. The Control channel is used for commands. The Data channel is used to receive and poll for measurement results. The Health channel is used to receive health indicators.

The port number used for each channel is configurable. Each port can accept multiple connections, up to a total of 16 connections for all ports.

Channels can share the same port or operate on individual ports. The default port number is 8190 for all channels. The following port numbers are reserved for Gocator internal use: 80, 843, 2000 - 2100, 2500 - 2600, 3100 - 3250.

## Asynchronous and Polling Operation

On the Ethernet output, the Data channel can operate asynchronously or by polling. Under asynchronous operation, measurement results are automatically sent on the Data channel when the sensor is in the running state and results become available. The result is sent on all connected data channels.

Under polling operation, when the sensor receives a Get Result command, it will send the latest measurement results on the same data channel that the request is received.

## Serial Communication

Gocator's serial communication is unidirectional (output only). Measurement results are sent on the Serial output in Asynchronous mode. While measurement values and decisions can be transmitted to an RS-485 receiver, configuration and control operations must be performed through the Gocator's web interface or through communications on the Ethernet output.

See *Serial Output* (page 354) for cable pinout information.

Gocator serial communication uses the following connection settings:

### *Serial Connection Settings*

<b>Parameter</b>	<b>Value</b>
Start Bits	1
Stop Bits	1
Parity	None
Data Bits	8
Baud Rate (b/s)	115200
Format	ASCII

## Command and Reply Format

Commands are sent from the client to the Gocator. Command strings are not case sensitive. The command format is:

<COMMAND><DELIMITER><PARAMETER><TERMINATION>

If a command has more than one parameter, each parameter is separated by the delimiter. Similarly, the reply has the following format:

<STATUS><DELIMITER><OPTIONAL RESULTS><DELIMITER>

The status can either be "OK" or "ERROR". The optional results can be relevant data for the command if successful, or a text based error message if the operation failed. If there is more than one data item, each item is separated by the delimiter.

The delimiter and termination characters are configured in the Special Character settings.

## Special Characters

The ASCII Protocol has three special characters.

### *Special Characters*

<b>Special Character</b>	<b>Explanation</b>
Delimiter	Separates input arguments in commands and replies, or data items in results. Default value is ",".
Terminator	Terminates both commands and result output. Default value is "%r%n".
Invalid	Represents invalid measurement results. Default value is "INVALID"

The values of the special characters are defined in the Special Character settings. In addition to normal ASCII characters, the special characters can also contain the following format values.

### *Format values for Special Characters*

<b>Format Value</b>	<b>Explanation</b>
%t	Tab
%n	New line
%r	Carriage return
%%	Percentage (%) symbol

## Standard Result Format

Measurement results can either be sent in the standard format or in a custom format. In the standard format, you select in the web interface which measurement values and decisions to send. For each measurement the following message is transmitted:

```
M tn , in , V vn , D d1 CR
```

Field	Shorthand	Length	Description
MeasurementStart	M	1	Start of measurement frame.
Type	t <sub>n</sub>	n	Hexadecimal value that identifies the type of measurement. The measurement type is the same as defined elsewhere (see page 276).
Id	i <sub>n</sub>	n	Decimal value that represents the unique identifier of the measurement.
ValueStart	V	1	Start of measurement value. This field and the following Value field are optional – they will only be present if the measurement value has been selected for transmission.
Value	v <sub>n</sub>	n	Measurement value, in decimal. The unit of the value is measurement-specific.
DecisionStart	D	1	Start of measurement decision. This field and the following Decision field are optional – they will only be present if the measurement decision has been selected for transmission.
Decision	d <sub>1</sub>	1	Measurement decision: 0 – Fail 1 – Pass

## Custom Result Format

In the custom format, you enter a format string with place holders to create a custom message. The default format string is "%time, %value[0], %decision[0]".

### Result Placeholders

Format Value	Explanation
%time	Timestamp
%encoder	Encoder position
%frame	Frame number
%value[Measurement ID]	Measurement value of the specified measurement ID
%decision[Measurement ID]	Measurement decision of the specified measurement ID

## Control Commands

Optional parameters are shown in *italics*. The placeholder for data is surrounded by brackets (<>). In the examples, the delimiter is set to '!':

### Start

The Start command starts the sensor system (causes it to enter the Running state). This command is only valid when the system is in the Ready state. If a start target is specified, the sensor starts at the target time or encoder (depending on the trigger mode).

#### Formats

Message	Format
Command	Start, start target  The start target (optional) is the time or encoder position at which the sensor will be started. The time and encoder target value should be set by adding a delay to the time or encoder position returned by the Stamp command. The delay should be set such that it covers the command response time of the Start command.
Reply	OK or ERROR, <Error Message>

#### Examples:

```
Start
```

```
OK
```

```
Start,1000000
```

```
ok
```

```
Start
```

```
ERROR, Could not start the sensor
```

### Stop

The stop command stops the sensor system (causes it to enter the Ready state). This command is valid when the system is in the Ready or Running state.

#### Formats

Message	Format
Command	Stop
Reply	OK or ERROR, <Error Message>

#### Examples:

```
Stop
```

```
OK
```

## Trigger

The Trigger command triggers a single frame capture. This command is only valid if the sensor is configured in the Software trigger mode and the sensor is in the Running state. If a start target is specified, the sensor starts at the target time or encoder (depending on the unit setting in the Trigger panel; see page 64).

### Formats

Message	Format
Command	Trigger, start target The start target (optional) is the time or encoder position at which the sensor will be started. The time and encoder target value should be set by adding a delay to the time or encoder position returned by the Stamp command. The delay should be set such that it covers the command response time of the Start command.
Reply	OK or ERROR, <Error Message>

### Examples:

```
Trigger
```

```
OK
```

```
Trigger,1000000
```

```
OK
```

## Load Configuration

The Load Configuration command switches the active sensor configuration.

### Formats

Message	Format
Command	LoadConfig, configuration file name If the configuration file name is not specified, the command returns the current configuration name. An error message is generated if there is no configuration loaded. ".cfg" is appended if the filename does not have an extension. If you specify a file ending with the ".cfg" extension, only a configuration will be loaded, unless you are switching from a configuration whose calibration was performed with <b>Source</b> set to <b>Current Configuration</b> in the <b>Layout</b> panel (see <i>Transformation Sources</i> (page 79) for more details) to a configuration that uses global transformations. In the latter case, global transformations will also be loaded. If you specify a file ending with the ".set" extension, a configuration, the transformations that were associated with it by performing calibration using <b>Current Configuration</b> , and a template (if in profile mode and a template has been registered) will be loaded.
Reply	OK or ERROR, <Error Message>

### Examples:

```
LoadConfig,test.cfg
```

```

OK, test.cfg loaded successfully

LoadConfig

OK, test.cfg

LoadConfig, wrongname.cfg

ERROR, failed to load wrongname.cfg

OK

```

## Stamp

The Stamp command retrieves the current time, encoder and/or the last frame count.

### Formats

Message	Format
Command	Stamp, time, encoder, frame If no parameters are given, time, encoder and frame will be returned. There could be more than one selection.
Reply	If no arguments are specified OK, time, <time value>, encoder, <encoder position>, frame, <frame count> ERROR, <Error Message> If arguments are specified, only the selected stamps will be returned.

### Examples:

```

Stamp

OK, Time, 9226989840, Encoder, 0, Frame 6

Stamp frame

OK, 6

OK, test.cfg

LoadConfig, wrongname.cfg

```

## Alignment Calibration

The Alignment Calibration command performs an alignment calibration based on the calibration settings in the sensor's live configuration. A reply to the command is sent when the calibration has completed or failed. The command is timed out if there has been no progress after one minute.

### Formats

Message	Format
Command	AlignCalibrate
Reply	If no arguments are specified OK or ERROR, <Error Message>

Examples:

```
AlignCalibrate
```

```
OK
```

```
AlignCalibrate
```

```
ERROR, ALIGNMENT CALIBRATION FAILED
```

## Travel Calibration

The Travel Calibration command performs a travel calibration based on the calibration settings in the sensor's live configuration. A reply to the command is sent when the calibration has completed or failed. The command is timed out if there has been no progress after one minute.

### Formats

Message	Format
Command	TravelCalibrate
Reply	If no arguments are specified OK or ERROR, <Error Message>

Examples:

```
TravelCalibrate
```

```
OK
```

```
TravelCalibrate
```

```
ERROR, TRAVEL CALIBRATION FAILED
```

## Clear Calibration

The Clear Calibration command clears the calibration record generated by alignment or travel calibration.

### Formats

Message	Format
Command	ClearCalibration
Reply	OK or ERROR, <Error Message>

Examples:

```
ClearCalibration
```

```
OK
```

## Data Commands

Optional parameters are shown in *italic*. The placeholder for data is surrounded by brackets (<>). In the examples, the delimiter is set to ','.

## Get Result

The Get Result command retrieves measurement values and decisions.

### Formats

Message	Format
Command	Result, measurement ID, measurement ID...
Reply	If no arguments are specified, the custom format data string is used. OK, <custom data string> ERROR, <Error Message> If arguments are specified, OK, <data string in standard format> ERROR, <Error Message>

Examples:

Standard data string for measurements ID 0 and 1:

```
Result,0,1
```

```
OK,M00,00,V151290,D0,M01,01,V18520,D0
```

Standard formatted measurement data with a non-existent measurement of ID 2:

```
Result,2
```

```
ERROR,Specified measurement ID not found. Please verify your input
```

Custom formatted data string (%time, %value[0], %decision[0]):

```
Result
```

```
OK,1420266101, 151290, 0
```

## Get Value

The Get Value command retrieves measurement values.

### Formats

Message	Format
Command	Value, measurement ID, measurement ID...
Reply	If no arguments are specified, the custom format data string is used. OK, <custom data string> ERROR, <Error Message> If arguments are specified, OK, <data string in standard format, except that the decisions are not sent> ERROR, <Error Message>

Examples:

Standard data string for measurements ID 0 and 1:

```
Value,0,1
```

```
OK,M00,00,V151290,M01,01,V18520
```

Standard formatted measurement data with a non-existent measurement of ID 2:

```
Value,2
```

```
ERROR,Specified measurement ID not found. Please verify your input
```

Custom formatted data string (%time, %value[0]):

```
Value
```

```
OK, 1420266101, 151290
```

## Get Decision

The Get Decision command retrieves measurement decisions.

### Formats

Message	Format
Command	Decision, measurement ID, measurement ID...
Reply	If no arguments are specified, the custom format data string is used. OK, <custom data string> ERROR, <Error Message> If arguments are specified, OK, <data string in standard format, except that the values are not sent> ERROR, <Error Message>

Examples:

Standard data string for measurements ID 0 and 1:

```
Decision,0,1
```

```
OK,M00,00,D0,M01,01,D0
```

Standard formatted measurement data with a non-existent measurement of ID 2:

```
Decision,2
```

```
ERROR,Specified measurement ID not found. Please verify your input
```

Custom formatted data string (%time, %decision[0]):

```
Decision
```

```
OK,1420266101, 0
```

## Health Commands

Optional parameters are shown in *italic*. The placeholder for data is surrounded by brackets (<>). In the examples, the delimiter is set to ','.

### Get Health

The Get Health command retrieves health indicators. See *Health Results* (page 281) for details on health indicators.

#### Formats

Message	Format
Command	Health, health indicator ID.health indicator instance ... More than one health indicator can be specified. Note that the health indicator instance is optionally attached to the indicator ID with a '!'. If the health indicator instance field is used the delimiter cannot be set to '!'. <hr/>
Reply	OK, <health indicator of first ID>, <health indicator of second ID> ERROR, <Error Message>

#### Examples:

health, 2002, 2017

OK, 46, 1674

Health

ERROR, Insufficient parameters.

# Software Development Kit

The Gocator Software Development Kit (SDK) includes open-source software libraries and documentation that can be used to programmatically access and control Gocator sensors.

The latest version of the SDK can be downloaded from the downloads section, under the support tab, on the LMI Technologies website: <http://www.lmi3d.com>.

The following components are included in the SDK.

Component	Description
Gocator API	Gocator API is a C language library that provides support for the commands and data formats used with Gocator sensors.
Gocator Console	Gocator Console is a small console-based application that demonstrates the use of Gocator API.

A pre-built DLL is provided to support 32-bit Windows XP (SP3+) and 32-bit Windows 7. Projects and makefiles are included to support other editions of Windows and Linux.



The Gocator 3.6 SDK can be used to upgrade or downgrade the firmware of sensors running *any* version of Gocator. See [http://lmi3d.com/sites/default/files/APPNOTE\\_Gocator\\_SDK\\_Firmware\\_Upgrade\\_Guide.zip](http://lmi3d.com/sites/default/files/APPNOTE_Gocator_SDK_Firmware_Upgrade_Guide.zip) for instructions and sample code.

## Example: Configuring and starting a sensor with the Gocator API

```
#include <Go2.h>

void main()
{
    Go2System system = 0;
    //Open the Go2 library.
    Go2Api_Initialize();
    //Construct a Gocator system object.
    Go2System_Construct(&system);
    //Connect to default sensor IP address, with default password (blank).
    Go2System_Connect(system, GO2_DEFAULT_IP_ADDRESS, GO2_USER_ADMIN, "");
    //Reconfigure system to use time-based triggering.
    Go2System_SetTriggerSource(system, GO2_TRIGGER_SOURCE_TIME);
    //Send the system a "Start" command.
    Go2System_Start(system);
    //Free the system object.
    Go2System_Destroy(system);
}
```

```

//Close the Go2 library.
Go2Api_Terminate();
}

```

For more information about programming with the Gocator SDK, refer to the documentation and sample programs included in the Gocator SDK.

## Limiting Flash Memory Write Operations

Several operations and Gocator SDK functions write to the Gocator's flash memory. The lifetime of the flash memory is limited by the number of write cycles. Therefore it is important to avoid frequent write operation to the Gocator's flash memory when you design your system with the Gocator SDK.

 Power loss during flash memory write operation will also cause Gocators to enter rescue mode.

 This topic applies to all Gocator sensors.

### *Gocator SDK Write-Operation Functions*

<b>Name</b>	<b>Description</b>
Go2System_Restore	Restores a backup of sensor files.
Go2System_RestoreDefaults	Restores factory default settings.
Go2System_CopyFile	Copies a file within the connected sensor. The flash write operation does not occur if the Go2System_CopyFile function is used to load an existing configuration, transformation, or profile template. This is accomplished by specifying “_live” as the destination file name.
Go2System_DeleteFile	Deletes a file in the connected sensor.
Go2System_SetDefaultFile	Sets a default configuration or template file to be loaded on boot.
Go2System_ClearRegisteredTemplate	Clears the registered profile template.
Go2System_UploadFile	Uploads a file to the connected sensor.
Go2System_Upgrade	Upgrades system firmware.
Global calibration performed with Go2System_Start	Global calibration writes to flash memory immediately. Global calibration is configured in the SDK when Go2CalibrationSource parameter is set to GO2_CALIBRATION_SOURCE_GLOBAL with Go2System_SetCalibrationSource() function. Gocator performs calibration with GoSystem_Start call when in calibration mode set by Go2System_SetMode().
Go2System_SetConnectionType	Sets the type of sensor connection (custom, master, etc.).
Go2System_SetAddress	Locates a Gocator sensor by id (serial number) and configures its network address settings.
Go2System_ChangePassword	Changes the password associated with the specified user account.

System created using the SDK should be designed in a way that parameters are set up to be appropriate for various application scenarios. Parameter changes not listed above will not invoke flash memory write operations when the changes are not saved to a file using the Go2System\_CopyFile function. Local calibration should be used as a means to attach previously conducted calibration results to a configuration file, eliminating the need to perform a new calibration.

# Tools and Native Drivers

The following sections describe the tools and native drivers you can use with a Gocator.

## Sensor Recovery Tool

If a sensor's network address or administrator password is forgotten, the sensor can be discovered on the network and/or restored to factory defaults by using a special software tool called the Sensor Discovery tool. This software tool can be obtained from the downloads area of the LMI Technologies website: <http://www.lmi3D.com>.

After downloading the tool package [14405-x.x.x.x\_SOFTWARE\_Go2\_Tools.zip], unzip the file and run the Sensor Discovery Tool [bin>win32>kDiscovery.exe].

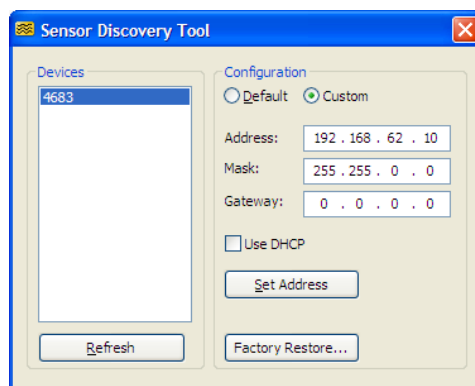

Any sensors that are discovered on the network will be displayed in the Devices list.

*To change the network address of a sensor:*

1. To change the network address of a sensor.
2. Select the **Custom** option.
3. Enter the new network address information.
4. Press the Set Address button.

*To restore a sensor to factory defaults:*

1. Select the sensor serial number in the **Devices** list.
2. Press the **Factory Restore...** button.  
Confirm when prompted.



The Sensor Discovery tool uses UDP broadcast messages to reach sensors on different subnets. This enables the Sensor Discovery tool to locate and re-configure sensors even when the sensor IP address or subnet configuration is unknown.

# GenTL Driver

GenTL is an industry standard method of controlling and acquiring data from an imaging device. Gocator provides a GenTL driver that allows GenTL-compliant third-party software (e.g., Halcon and Common Vision Blox) to acquire and process 3D point clouds and intensity generated from the Gocator's Raw and Whole Part modes in real-time.

You can get the tool package containing the driver from the downloads area on the LMI Technologies website at <http://lmi3d.com/support/downloads/>.

After downloading the tool package (14453-x.x.x.x\_SOFTWARE\_Go2\_Integration\_Tools.zip), unzip the file. The driver is found under the GenTL\x86 directory.

*To install the driver in Windows 7:*

1. Open the **Control** panel.
2. Select **System and Security** and then click **System**.
3. Click **Advanced System Settings**.  
The **Advanced System Settings** link is typically in the left column of the window.
4. For 32-bit systems, click **New** to create a system environment variable GENICAM\_GENTL32\_PATH and point it to the GenTL\x86 directory.  
If the system environment variable already exists, click **Edit**.
5. For 64-bit systems, click **New** to create a system environment variable GENICAM\_GENTL64\_PATH and point it to the GenTL\x64 directory.  
If the system environment variable already exists, click **Edit**.

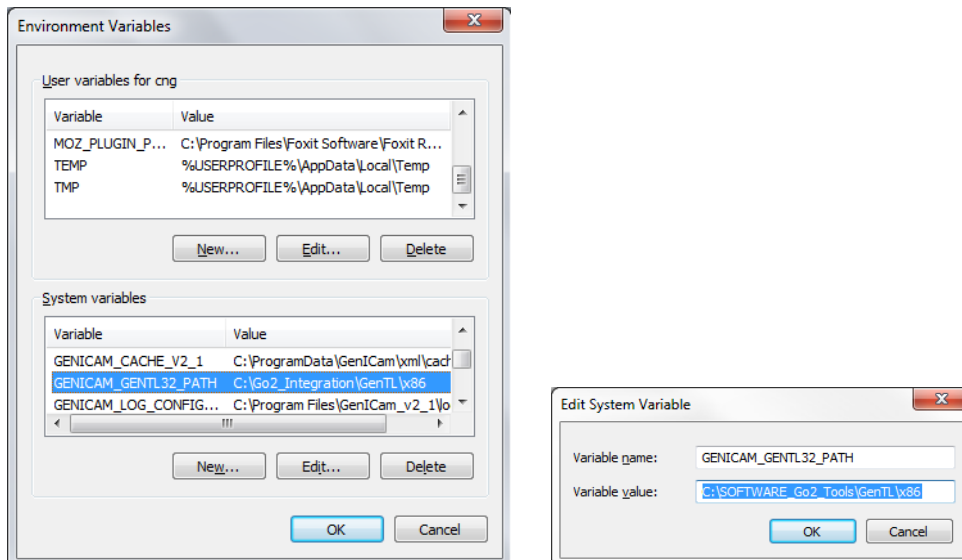

To work with the Gocator GenTL driver, the Gocator must operate in Whole Part mode with its part output enabled in the Ethernet Output Panel. Check "Acquire Intensity" and enable intensity output in the **Ethernet** panel in the **Output** page if intensity data is required.

Refer to the documentations in the GenTL\ directory for instructions on how to interface to various third party software.

Gocator GenTL driver packs the part output, intensity and stamps (e.g., time stamp, encoder index, etc.) into either a 16-bit RGB image or a 16-bit grey scale image. You can select the format in the Go2GenTL.xml setting file.

The width and height of the 16-bit RGB or grey scale image is calculated from the maximum number of columns and rows required to support the sensor's FOV and the maximum part length.

## 16-bit RGB Image

When the 16-bit RGB format is used, the height map, intensity, and stamps are stored in the red, green, and blue channel respectively.

Channel	Details
Red	<p>Height map information. The width and height of the image represent the dimensions in the X and Y axis. Together with the pixel value, each red pixel presents a 3D point in the real-world coordinates.</p> <p>The following formula can be used to calculate the real-world coordinates (X, Y, Z) from pixel coordinates (Px, Py, Pz):</p> $X = X \text{ offset} + Px * X \text{ resolution}$ $Y = Y \text{ offset} + Py * Y \text{ resolution}$ $Z = Z \text{ offset} + Pz * Z \text{ resolution}$ <p>Refer to the blue channel on how to retrieve the offset and resolution values. If Pz is 0 if the data is invalid. The Z offset is fixed to <math>-32768 * Z \text{ resolution}</math>. Z is zero if Pz is 32768.</p>
Green	<p>Intensity information. Same as the red channel, the width and height of the image represent the dimension in the X and the Y axis. Together with the pixel value, each blue pixel represents an intensity value in the real-world coordinates.</p> <p>The following formula can be used to calculate the real-world coordinates (X, Y, Z) from pixel coordinates (Px, Py, Pz):</p> $X = X \text{ offset} + Px * X \text{ resolution}$ $Y = Y \text{ offset} + Py * Y \text{ resolution}$ $Z = 16\text{-bit intensity value}$ <p>The intensity value is 0 if the intensity image is not available. Gocator outputs 8-bit intensity values. The values stored in the 16-bit RGB image is multiplied by 256. To obtain the original values, divide the intensity values by 256.</p> <p>Refer to the blue channel on how to retrieve the offset and resolution values.</p>
Blue	<p>Stamp information. Stamps are 64-bit auxiliary information related to the height map and intensity content. The next table explains how the stamps are packed into the blue pixel channel</p> <p>See <i>Data Results</i> (page 276) for an explanation of the stamp information.</p>

The following table shows how the stamp information is packed into the blue channel. A stamp is a 64-bit value packed into four consecutive 16-bit blue pixels, with the first byte position storing the most significant byte.

### Stamp Information from GenTL driver

Stamp Index	Blue Pixel Position	Details
0	0..3	Version
1	4..7	Frame Count
2	8..11	Timestamp (us)
3	12..15	Encoder value (ticks)
4	16..19	Encoder index (ticks) This is the encoder value when the last index is triggered
5	20..23	Digital input states
6	24..27	X offset (nm)
7	28..31	X resolution(nm)
8	32..35	Y offset (nm)
9	36..39	Y resolution (nm)
10	40..43	Z offset (nm)
11	44..47	Z resolution (nm)
12	48..51	Height map Width (in pixels)
13	52..55	Height map length (in pixels)
14	56..59	Specify if the intensity is enabled

## 16-bit Grey Scale Image

When the 16-bit grey scale format is used, the height map, intensity, and stamps are stored sequentially in the grey scale image.

The last row of the image contains the stamp information.

Rows	Details
0 .. (max part height - 1)	<p>Height map information. The width and height of the image represent the dimensions in the X and Y axis. Together with the pixel value, each pixel presents a 3D point in the real-world coordinates.</p> <p>The following formula can be used to calculate the real-world coordinates (X, Y, Z) from pixel coordinates (Px, Py, Pz):</p> $X = X \text{ offset} + Px * X \text{ resolution}$ $Y = Y \text{ offset} + Py * Y \text{ resolution}$ $Z = Z \text{ offset} + Pz * Z \text{ resolution}$ <p>Refer to the blue channel on how to retrieve the offset and resolution values. If Pz is 0 if the data is invalid. The Z offset is fixed to <math>-32768 * Z \text{ Resolution}</math>. Z is zero if Pz is 32768.</p>
(max part height) .. 2* (max part height) If intensity is enabled	<p>Intensity information. The width and height of the image represent the dimension in the X and the Y axis. Together with the pixel value, each blue pixel represents an intensity value in the real-world coordinates.</p> <p>The following formula can be used to calculate the real-world coordinates (X, Y, Z) from pixel coordinates (Px, Py, Pz): The following formula assumes Py is relative to the first</p>

Rows	Details
	<p>row of the intensity information, not the first row of the whole 16-bit grey scale image.</p> <p><math>X = X \text{ offset} + P_x * X \text{ resolution}</math></p> <p><math>Y = Y \text{ offset} + P_y * Y \text{ resolution}</math></p> <p>Z = 16-bit intensity value</p> <p>This intensity value is 0 if the intensity image is not available. Gocator outputs 8-bit intensity values. The values stored in the 16-bit Grey scale image is multiplied by 256. To obtain the original values, divide the intensity values by 256.</p> <p>Refer to the stamps on how to retrieve the offset and resolution values.</p>
The last row of the 16-bit grey scale image	<p>Stamp information. Stamps are 64-bit auxiliary information related to the height map and intensity content. The next table explains how the stamps are packed into the blue pixel channel</p> <p>See <i>Data Results</i> (page 276) for an explanation of the stamp information.</p>

The following table shows how the stamp information is packed into the last row. A stamp is a 64-bit value packed into four consecutive 16-bit pixels, with the first byte position storing the most significant byte.

#### Stamp Information from GenTL driver

Stamp Index	Column Position	Details
0	0..3	Version
1	4..7	Frame Count
2	8..11	Timestamp (us)
3	12..15	Encoder value (ticks)
4	16..19	Encoder index (ticks) This is the encoder value when the last index is triggered
5	20..23	Digital input states
6	24..27	X offset (nm)
7	28..31	X resolution(nm)
8	32..35	Y offset (nm)
9	36..39	Y resolution (nm)
10	40..43	Z offset (nm)
11	44..47	Z resolution (nm)
12	48..51	Height map Width (in pixels)
13	52..55	Height map length (in pixels)
14	56..59	Specify if intensity is enabled or not

## Registers

GenTL registers are multiple of 32 bits. The registers are used to control the operation of the GenTL driver, send commands to the sensors, or to report the current sensor information.

## Register Map Overview

Register Address	Name	Read/Write	Length (bytes)	Description
260	WidthReg	RO	4	Specify the width of the returned images. The part height map is truncated if it is wider than the specified width.
264	HeightReg	RO	4	Specify the height of the returned images (i.e., length of the part). The part height map is truncated if it is longer than the specified length.
292	ResampleMode	RO	4	Enable the resampling logic in the GenTL driver 0 - Disable resampling 1 - Enable resampling When resampling is enabled, the GenTL driver will resample the height map so that the pixel spacing is the same in the X and Y axis.
296	EncoderValue0	RO	4	Report the current encoder value (least significant 32-bit). The current encoder value is latched from the sensor when this register is read.
300	EncoderValue1	RO	4	Report the current encoder value (most significant 32-bit). The encoder value is latched when EncoderValue0 register is read. User should read EncoderValue0 before reading EncoderValue1.
304	Configuration File	RW	16	Read the name of sensor live configuration file or switch (write) the sensor configuration file. The configuration name is NULL terminated and includes the extension ".cfg". Writing to this register causes the sensor to switch to the specified configuration.
320	Transformation X offset	RO	4	Return the sensor transformation X offset
324	Transformation Z offset	RO	4	Return the sensor transformation Z offset
328	Transformation Angle	RO	4	Return the sensor transformation angle
332	Transformation Orientation	RO	4	Return the sensor transformation orientation
336	Clearance distance	RO	4	Return the sensor clearance distance

## XML Settings File

The settings file, Go2GenTL.xml, resides in the same directory as the Gocator GenTL driver. Users can set the resample mode and output format by changing the setting in this file.

Element	Type	Description
ResampleMode	32u	Settings to disable or enable resampling mode: 0 - Disable 1 - Enable  When resampling mode is enabled, the GenTL driver will resample the height map so that the pixel spacing is the same in the X and Y axis. The default value is 1.
DataFormat	32u	Settings to choose 16-bit RGB or 16-bit grey scale image output: 0 - 16-bit RGB Image 1 - 16-bit grey scale Image The default value is 0

## CSV Converter Tool

After you have exported recorded data to CSV, you can use the Gocator CSV Converter Tool to convert the exported profile or part data into different formats, including ASCII (XYZI), 16-bit BMP, 16-bit PNG, and GenTL formats. You can get the tool package (14453-x.x.x.x\_SOFTWARE\_Go2\_Integration\_Tools.zip) from the download area on LMI's website at <http://lmi3d.com/support/downloads/>. See *Downloading, Exporting, and Uploading Recorded Data* (page 51) for more information on exporting recorded data.

After downloading the tool package, unzip the file and run the Gocator CSV Converter tool [bin>win32>kCsvConverter.exe].

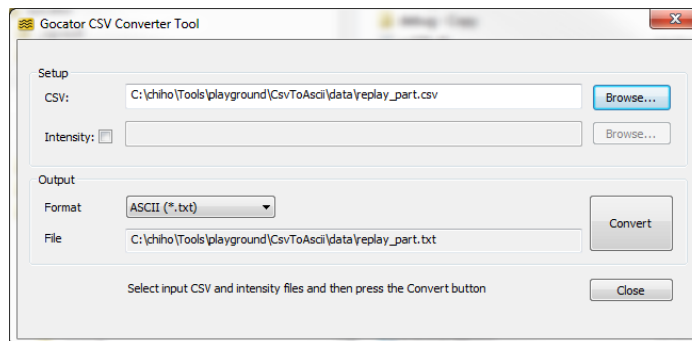

The software tool supports data exported from Profile or Whole Part mode. Data exported from Raw mode is not supported.



The GenTL format is a 48-bit RGB or grey scale PNG. Height map, intensity and stamp information are stored as defined in the GenTL Driver section (see page 313). You can load the exported data into image processing software to provide simulation data for developing applications using the GenTL driver.

*To convert exported CSV into different formats:*

1. Select the CSV file to convert.
2. If intensity information is required, check the **Intensity** box and select the intensity bitmap. Intensity information is only used when converting to ASCII or GenTL format. If intensity is not selected, the ASCII format will only contain the point coordinates (XYZ).
3. Select the output format.  
The converted file will reside in the same directory as the CSV file. It will also have the same name but with a different file extension. The converted file name is displayed in the **Output File** field.
4. Press the **Convert** button.

# Troubleshooting

Review the guidance in this chapter if you are experiencing difficulty with a Gocator sensor system. See *Return Policy* (page 377) for further assistance if the problem that you are experiencing is not described in this section.

## Mechanical/Environmental

The sensor is warm.

- It is normal for a sensor to be warm when powered on. A Gocator sensor is typically 15° C warmer than the ambient temperature.

## Connection

When attempting to connect to the sensor with a web browser, the sensor is not found (page does not load).

- Verify that the sensor is powered on and connected to the client computer network. The Power Indicator LED should illuminate when the sensor is powered.
- Check that the client computer's network settings are properly configured.
- Ensure that the latest version of Flash is loaded on the client computer.
- Use the LMI Discovery tool to verify that the sensor has the correct network settings. See *Sensor Recovery Tool* (page 311) for more information.

When attempting to log in, the password is not accepted.

- See *Sensor Recovery Tool* (page 311) for steps to reset the password.

## Laser Profiling

When the Start button or the Snapshot button is pressed, the sensor does not emit laser light.

- Ensure that the sticker covering the laser emitter window (normally affixed to new sensors) has been removed.
- The laser safety input signal may not be correctly applied. See *Specifications* (page 322) for more information.
- The exposure setting may be too low. See *Exposure* (page 71) for more information on configuring exposure time.
- Use the Snapshot button instead of the Start button to capture a laser profile. If the laser flashes when you use the **Snapshot** button, but not when you use the **Start** button, then the problem could be related to triggering. See *Trigger Panel* (page 64) for information on configuring the trigger source.

The sensor emits laser light, but the Range Indicator LED does not illuminate and/or points are not displayed in the Data Viewer.

- Verify that the measurement target is within the sensor's field of view and measurement range. See *Specifications* (page 322) to review the measurement specifications for your sensor model.
- Check that the exposure time is set to a reasonable level. See *Exposure* (page 71) for more information on configuring exposure time.

### **Performance**

The sensor CPU level is near 100%.

- Consider reducing the speed. If you are using a time or encoder trigger source, see *Trigger Panel* (page 64) for information on reducing the speed. If you are using an external input or software trigger, consider reducing the rate at which you apply triggers.
- Consider reducing the laser profile resolution. See *Resolutions* (page 75) for more information on configuring laser profile resolution.
- Review the measurements that you have programmed and eliminate any unnecessary measurements.

# Specifications

The following sections describe the specifications of the Gocator and its associated hardware.

## Gocator 2000 Series

The Gocator 2000 series consists of the sensor models defined below.

MODEL	2020	2030	2040	2050	2070	2075	2080
Data Points / Profile	640	640	640	640	640	640	640
Linearity Z (+/- % of MR)	0.02	0.02	0.02	0.02	0.05	0.05	0.05
Resolution Z (mm)	0.006 - 0.014	0.008 - 0.018	0.017 - 0.049	0.025 - 0.092	0.074 - 0.267	0.1750- 0.9250	0.123 - 0.650
Resolution X (mm)	0.03 - 0.04	0.088 - 0.15	0.19 - 0.34	0.30 - 0.60	0.55 - 1.1	0.55 - 1.65	0.75 - 2.2
Clearance Distance (CD) (mm)	40	90	190	300	400	650	350
Measurement Range (MR) (mm)	25	80	210	400	500	1350	800
Field of View (FOV) (mm)	18 - 25	47 - 85	96 - 194	158 - 365	308 - 687	352 - 1060	390 - 1260
Recommended Laser Class	2M	2M	3R	3R	3B	3B	3B
Dimensions (mm)	65x82x142	65x75x142	65x75x197	65x75x272	65x75x272	65x75x272	65x75x272
Weight (kg)	1	1	1.15	1.45	1.45	1.45	1.45

Optical models, laser classes, and packages can be customized. Contact LMI for more details.

Specifications stated are based on standard laser classes. Resolution Z and Linearity Z may vary for other laser classes.

### ALL 2000 SERIES MODELS

Scan Rate	Approx. 300 Hz - 5000 Hz
Interface	100 Mbaud Ethernet
Inputs	Differential Encoder, Laser Safety Enable, Trigger
Outputs	2x Digital Output, RS-485 Serial (115 Kbaud), 1x Analog Output (4 - 20 mA)
Input Voltage (Power)	+24 to +48 VDC (13 Watts); Ripple +/- 10%
Housing	Gasketed aluminum enclosure, IP 67
Operating Temp.	0 to 50° C
Storage Temp.	-30 to 70° C

# Gocator 2020

## Field of View / Measurement Range

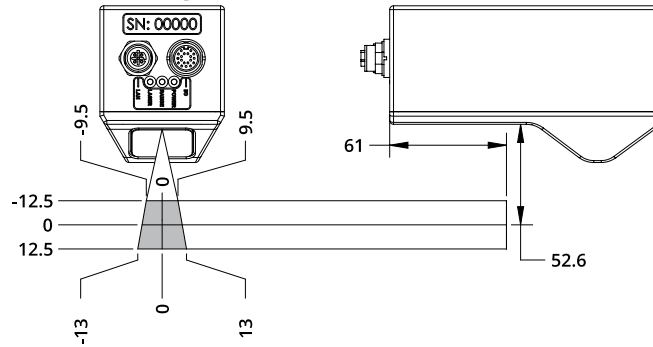

## Dimensions

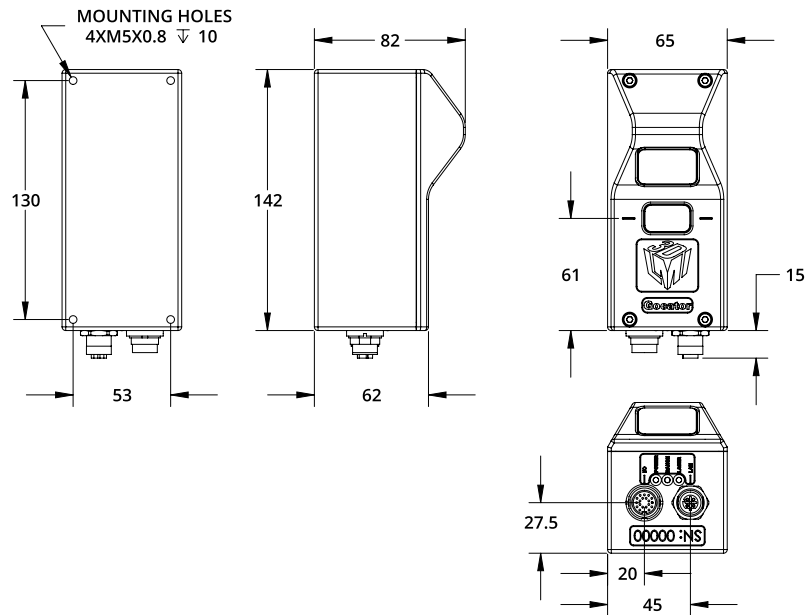

## Envelope

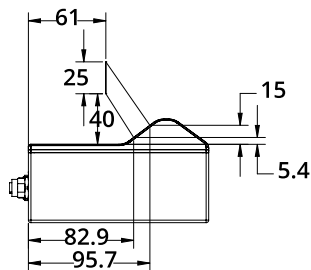

# Gocator 2030

## Field of View / Measurement Range

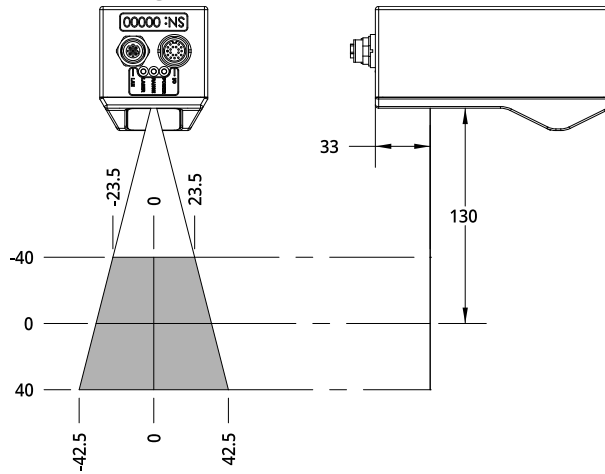

## Dimensions

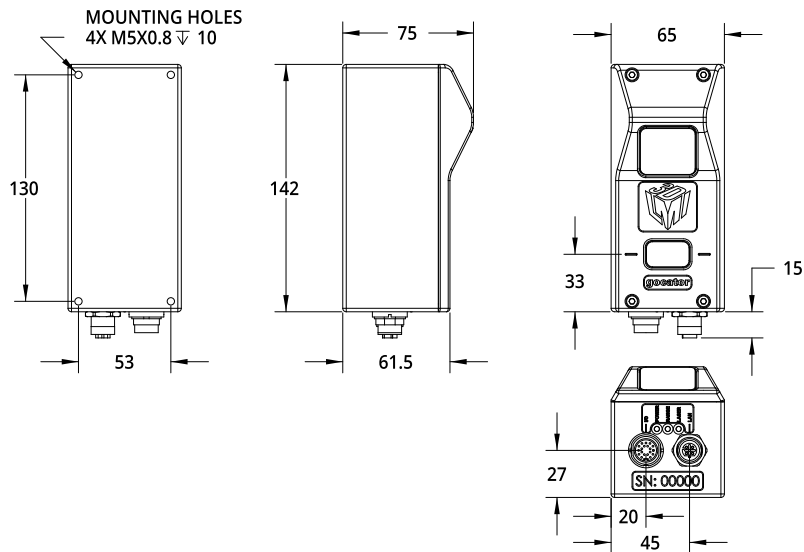

## Envelope

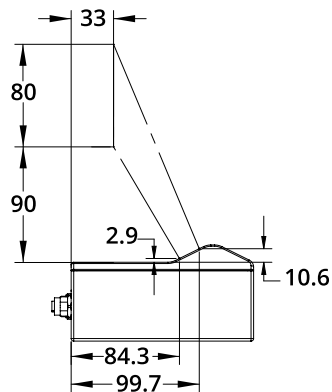

# Gocator 2040

## Field of View / Measurement Range

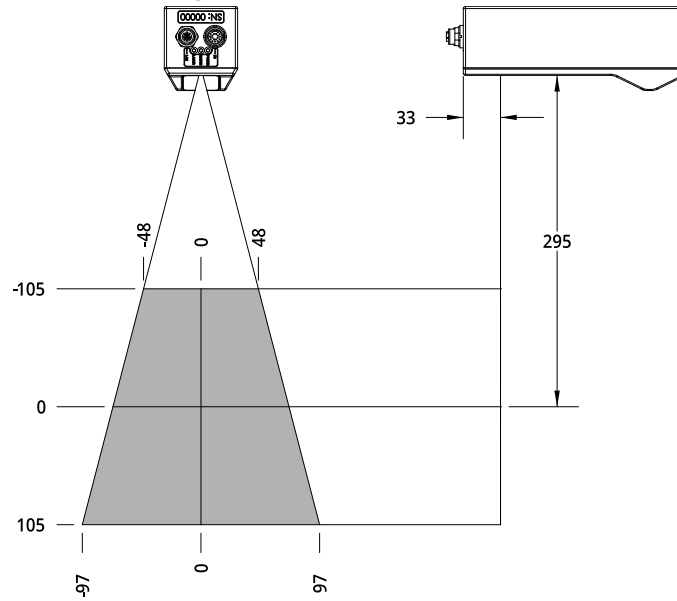

## Dimensions

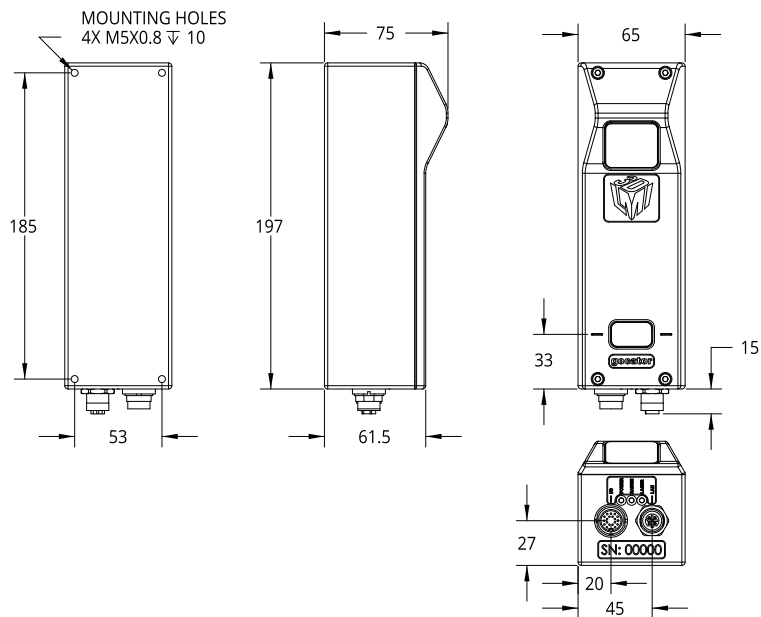

## Envelope

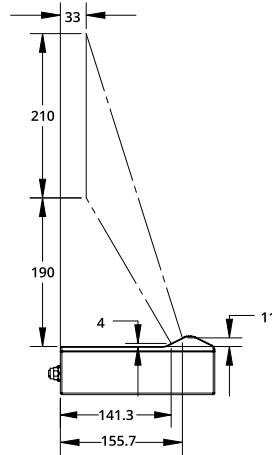

## Gocator 2050

### Field of View / Measurement Range

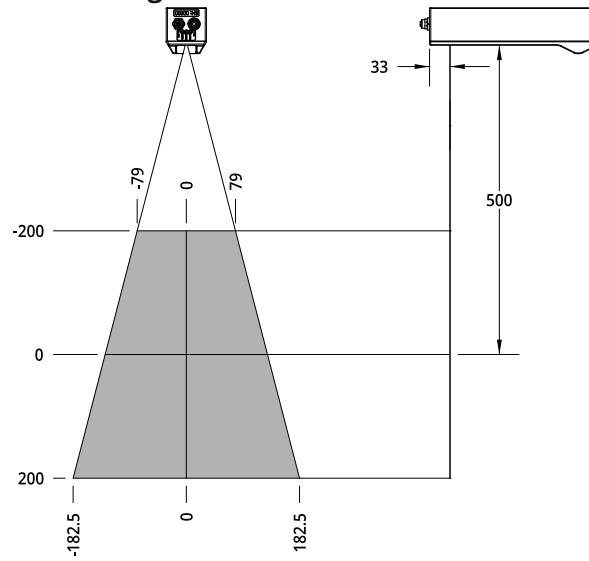

# Dimensions

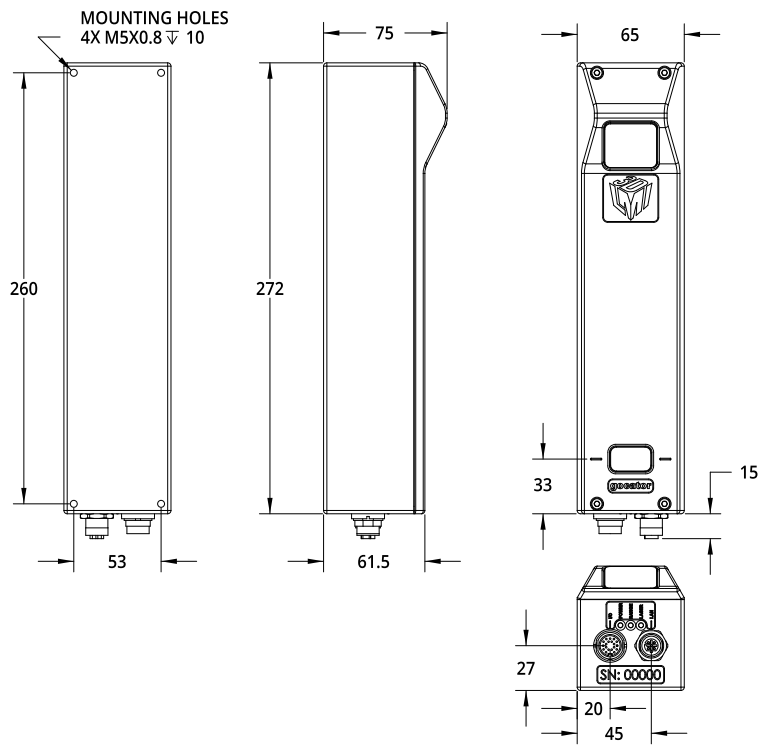

Envelope

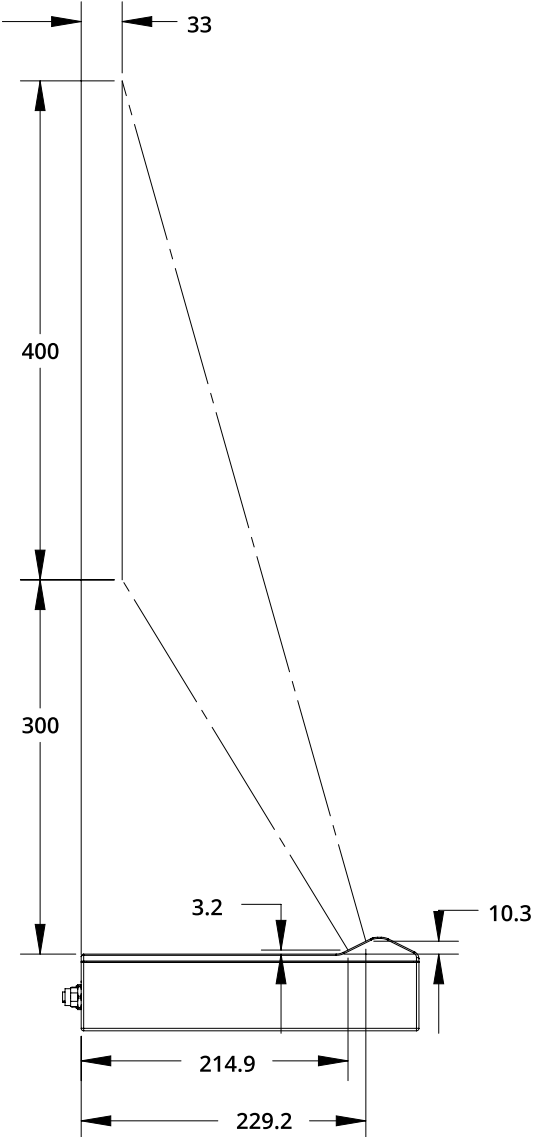

# Gocator 2070

## Field of View / Measurement Range

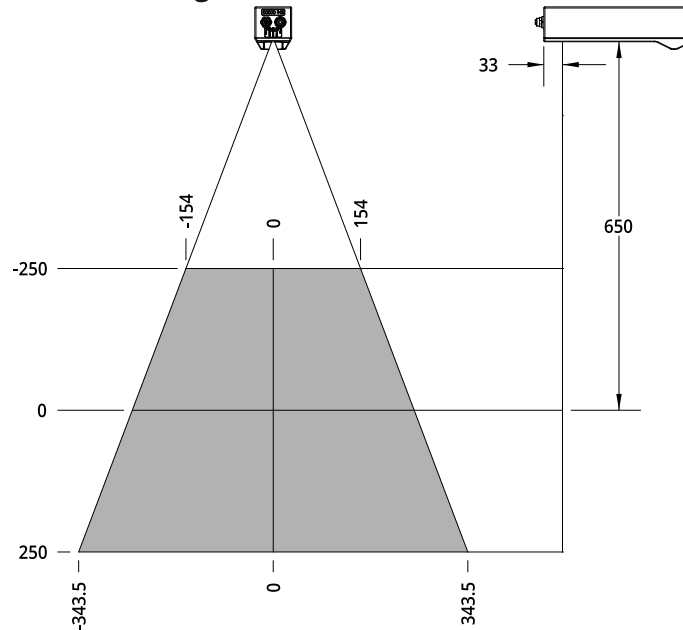

## Dimensions

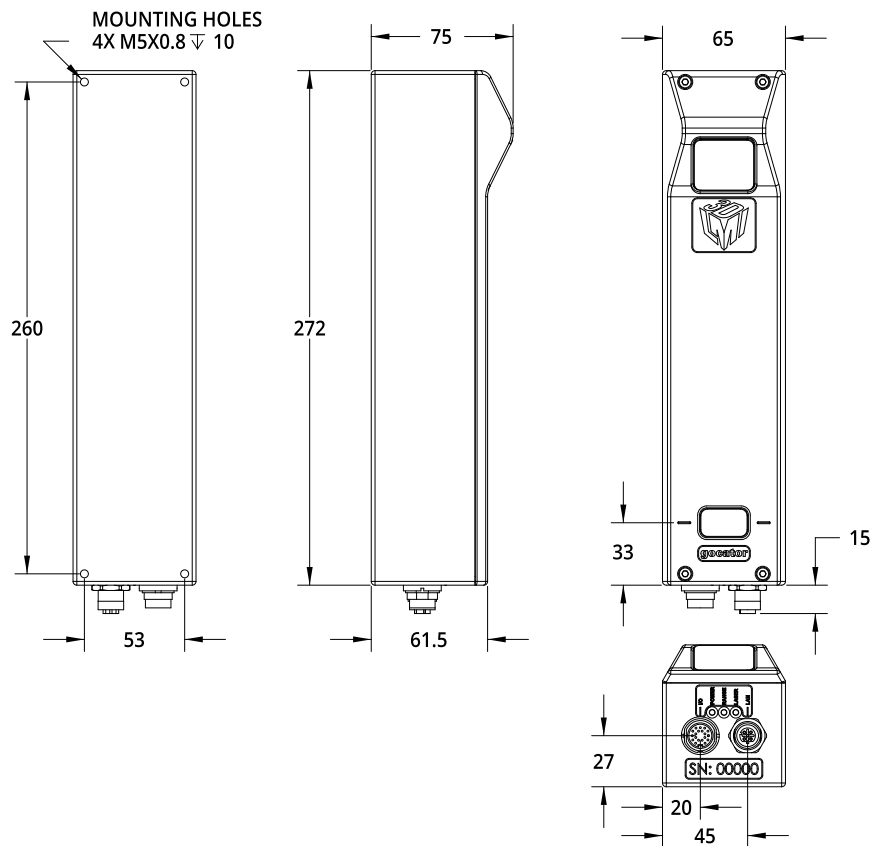

Envelope

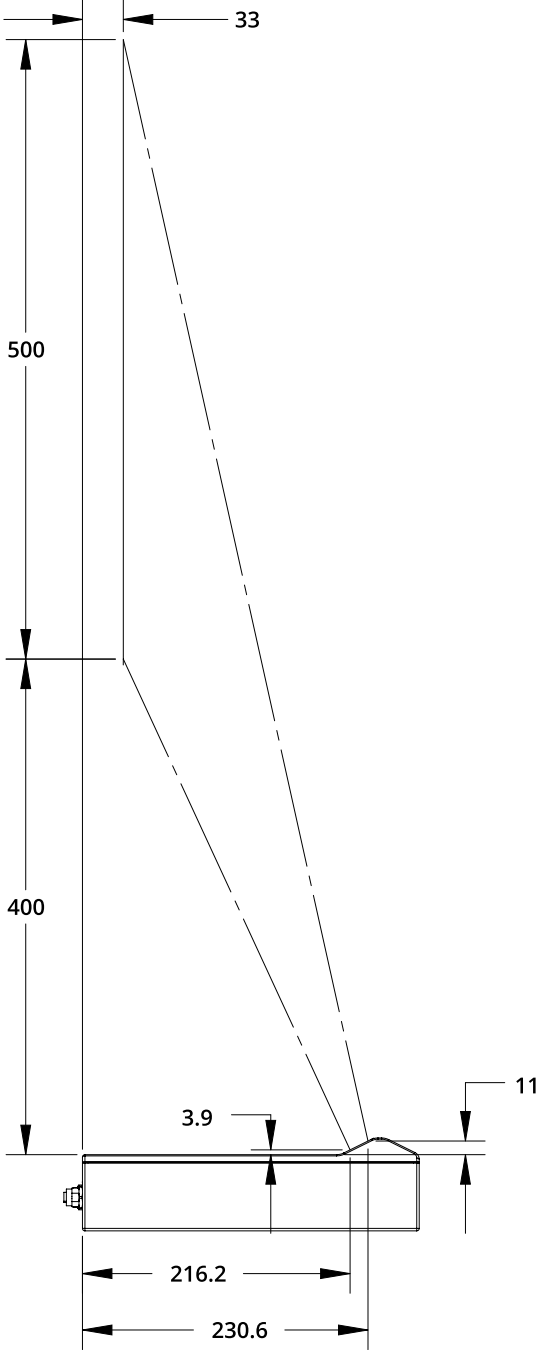

# Gocator 2075

## Field of View / Measurement Range

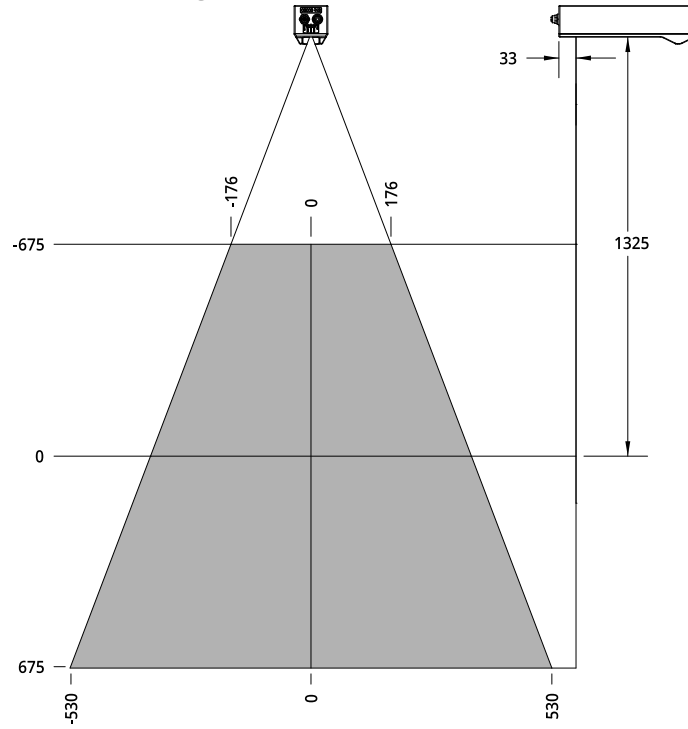

# Dimensions

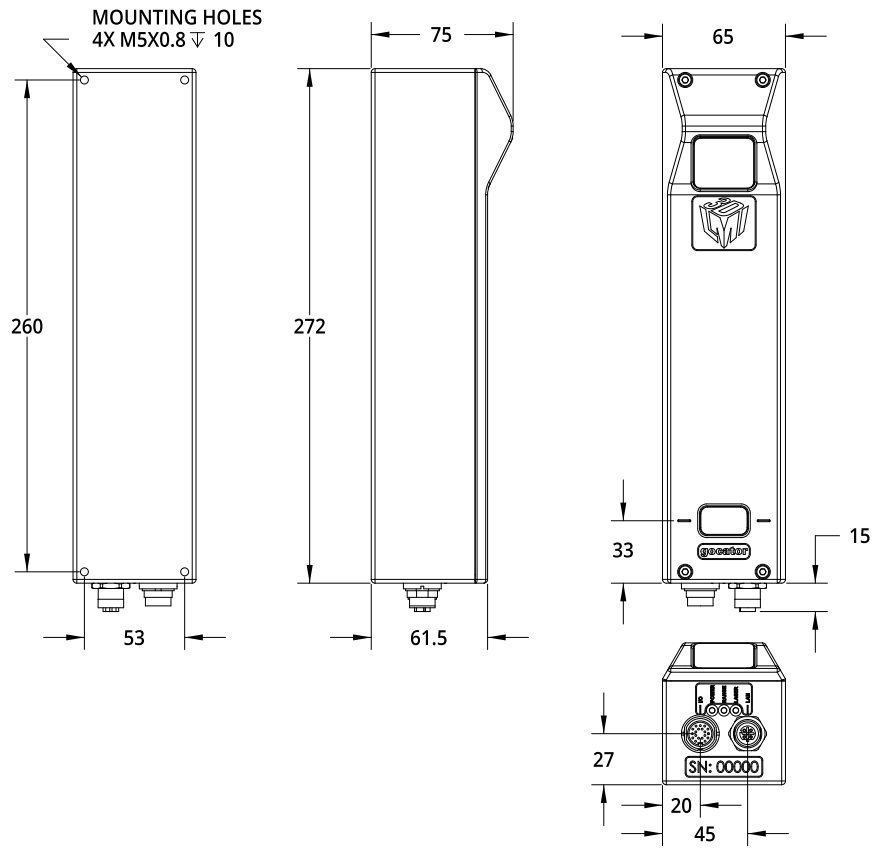

Envelope

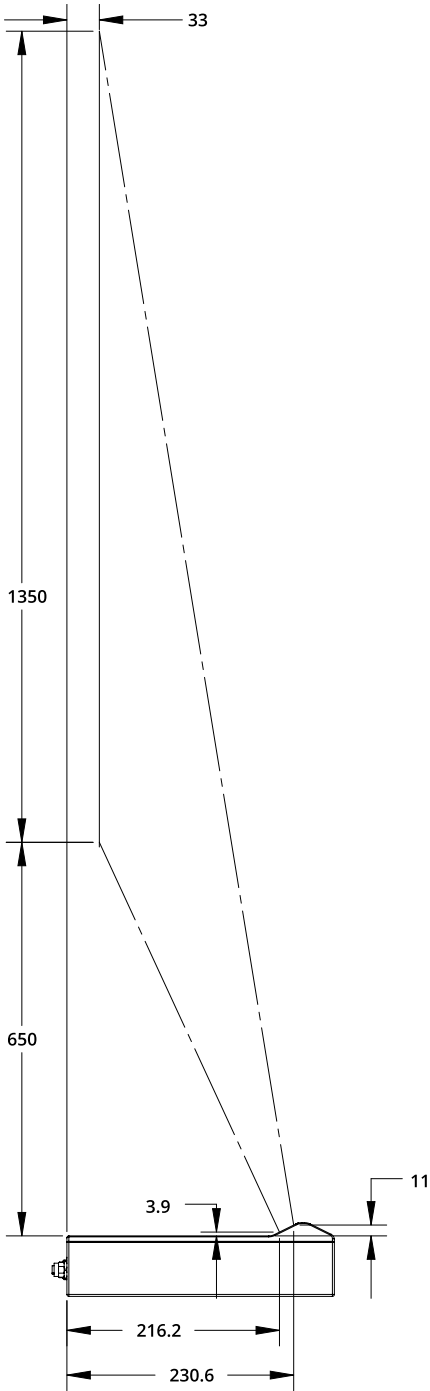

# Gocator 2080

## Field of View / Measurement Range

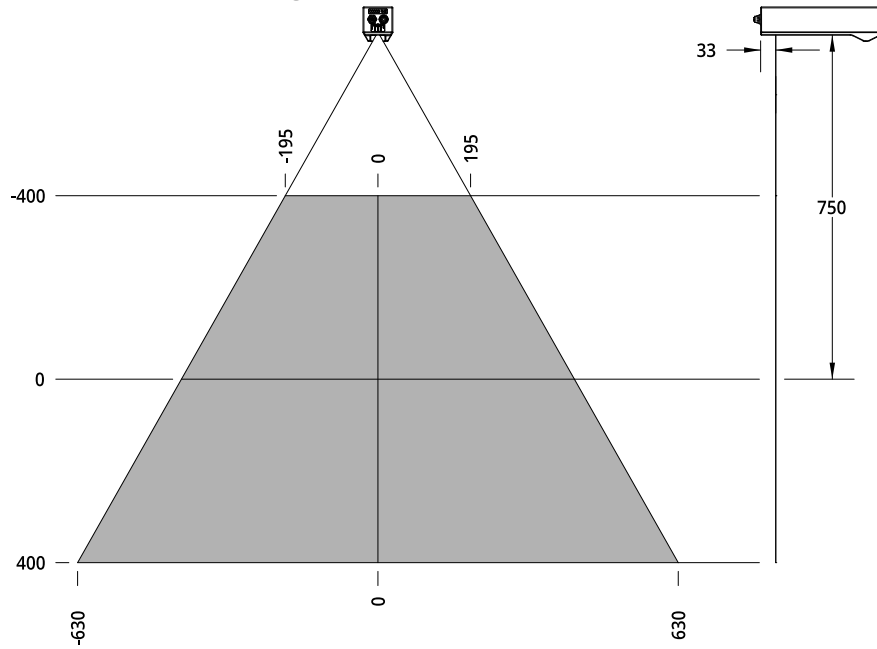

## Dimensions

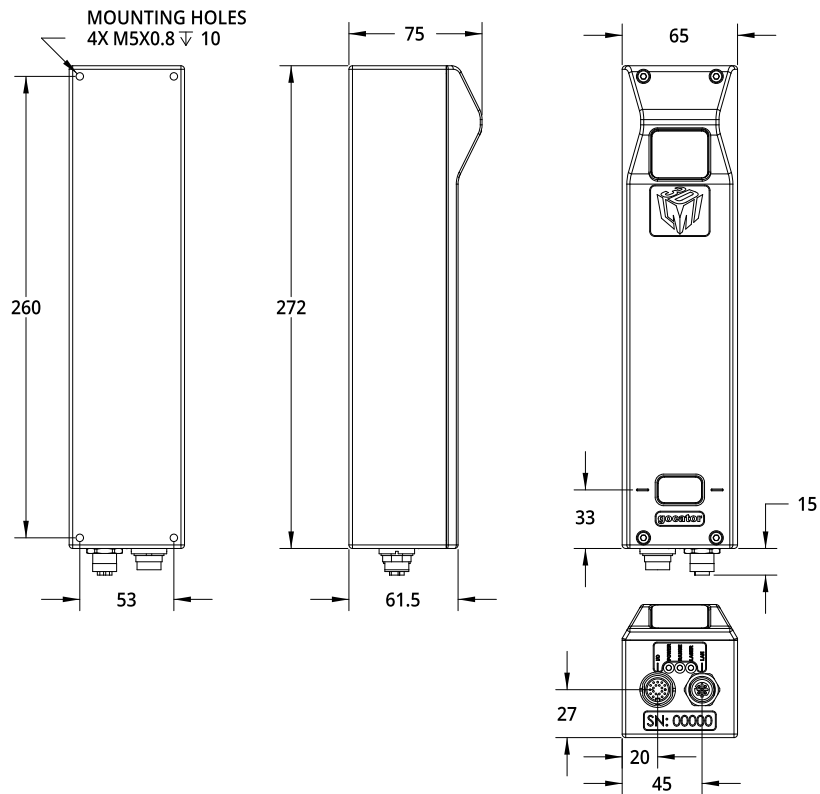

Envelope

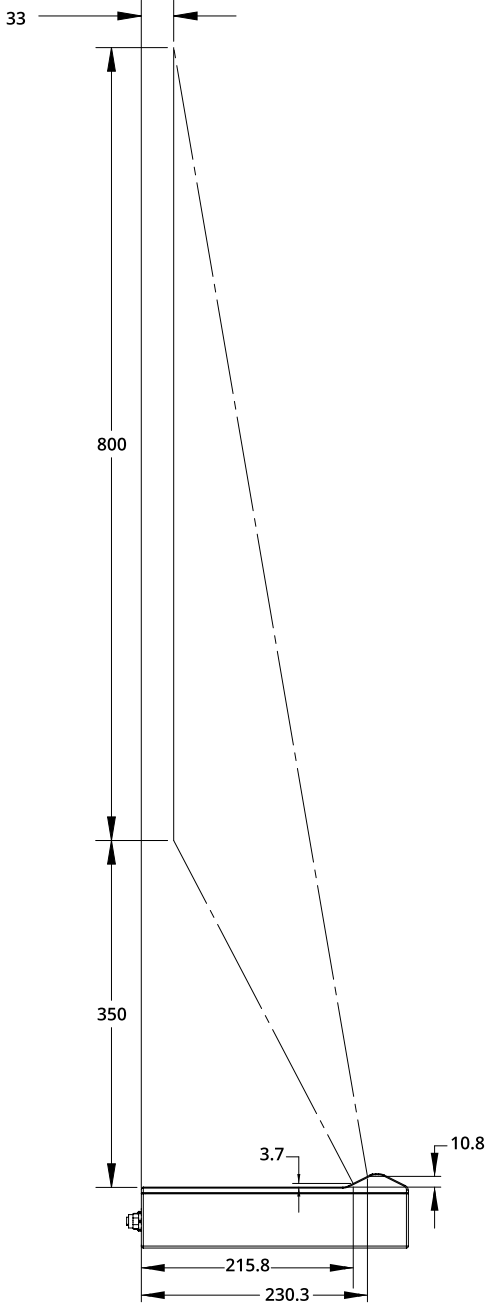

# Gocator 2300 Series

The Gocator 2300 series consists of the sensor models defined below.

MODEL	2330	2340	2350	2370	2375	2380
Data Points / Profile	1280	1280	1280	1280	1280	1280
Linearity Z (+/- % of MR)	0.01	0.01	0.01	0.04	0.05	0.04
Resolution Z (mm)	0.006 - 0.014	0.013 - 0.037	0.019 - 0.060	0.055 - 0.200	0.154 - 0.56	0.092 - 0.488
Resolution X (mm) (Profile Data Interval)	0.044 - 0.075	0.095 - 0.170	0.150 - 0.300	0.275 - 0.550	0.27 - 0.80	0.375 - 1.100
Repeatability Z ( $\mu$ m)	0.8	1.2	2	8	N/A	12
Clearance Distance (CD) (mm)	90	190	300	400	650	350
Measurement Range (MR) (mm)	80	210	400	500	1350	800
Field of View (FOV) (mm)	47 - 85	96 - 194	158 - 365	308 - 687	345 - 1028	390 - 1260
Recommended Laser Class	2M	3R	3R	3B	3B-N	3B
Other Laser Classes	3R, 3B	3B	3B			
Dimensions (mm)	49x75x142	49x75x197	49x75x272	49x75x272	49x75x272	49x75x272
Weight (kg)	0.74	0.94	1.3	1.3	1.3	1.3

Optical models, laser classes, and packages can be customized. Contact LMI for more details.

Specifications stated are based on standard laser classes. Linearity Z, Resolution Z, and Repeatability Z may vary for other laser classes.

All specification measurements are performed on LMI's standard calibration target (a diffuse, painted white surface).

Linearity Z is the worst case difference in average height measured, compared to the actual position over the measurement range.

Resolution Z is the maximum variability of height measurements across multiple frames, with 95% confidence.

Resolution X is the distance between data points along the laser line.

Repeatability Z is measured with a flat target at the middle of the measurement range. It is the 95% confidence variation of the average height over 4096 frames. Height values are averaged over the full FOV.

See *Resolution and Accuracy* (page 42) for more information.

**ALL 2300 SERIES MODELS**

Scan Rate	Approx. 170Hz to 5000 Hz
Interface	Gigabit Ethernet
Inputs	Differential Encoder, Laser Safety Enable, Trigger
Outputs	2x Digital output, RS-485 Serial (115 kBaud), 1x Analog Output (4 - 20 mA)
Input Voltage (Power)	+24 to +48 VDC (13 Watts); RIPPLE +/- 10%
Housing	Gasketed aluminum enclosure, IP67
Operating Temp.	0 to 50° C
Storage Temp.	-30 to 70° C

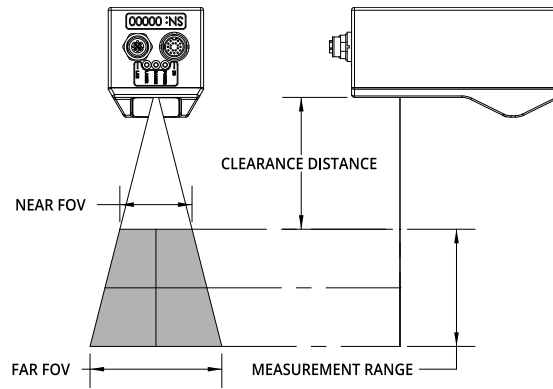

Mechanical dimensions for each sensor model are illustrated on the following pages.

**Gocator 2330**

**Field of View / Measurement Range**

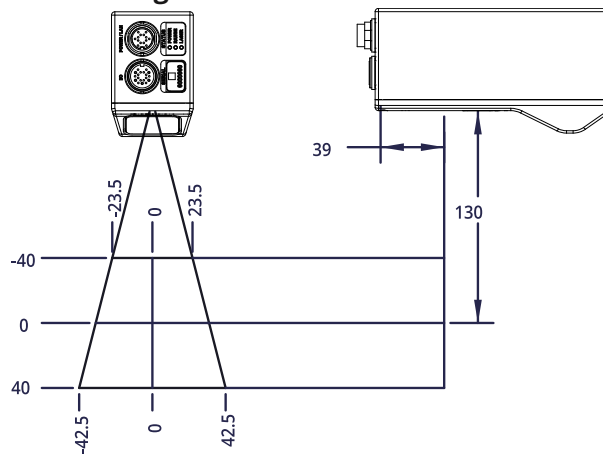

## Dimensions

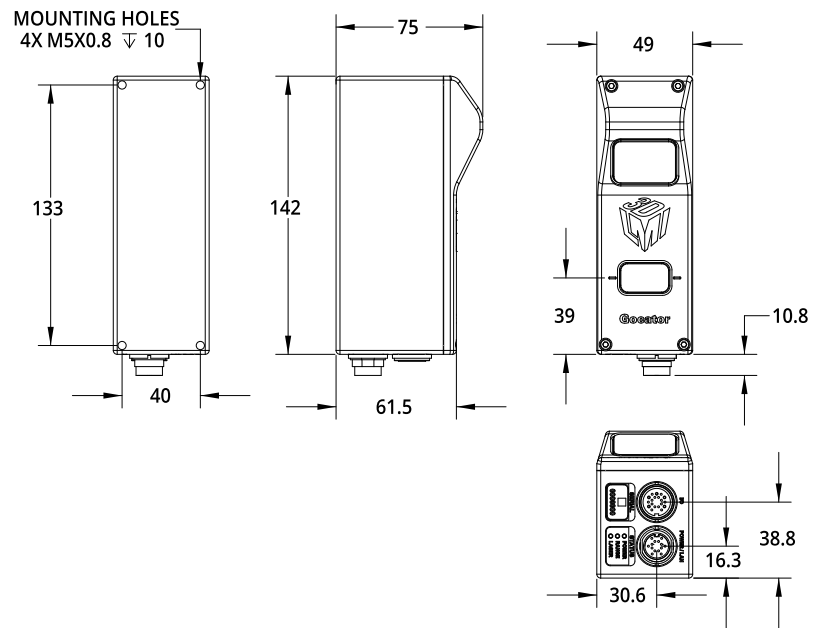

## Envelope

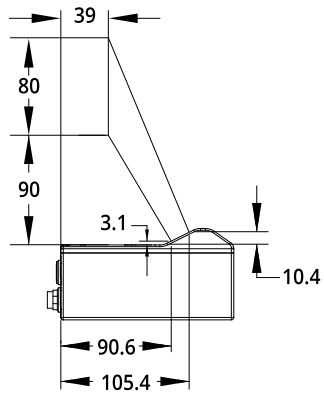

# Gocator 2340

## Field of View / Measurement Range

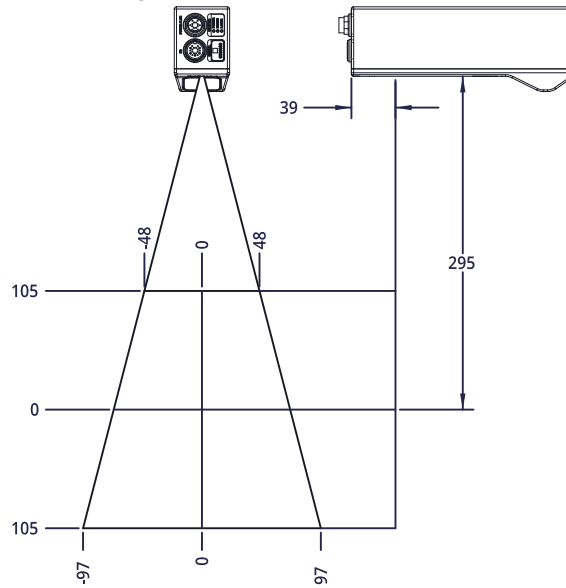

## Dimensions

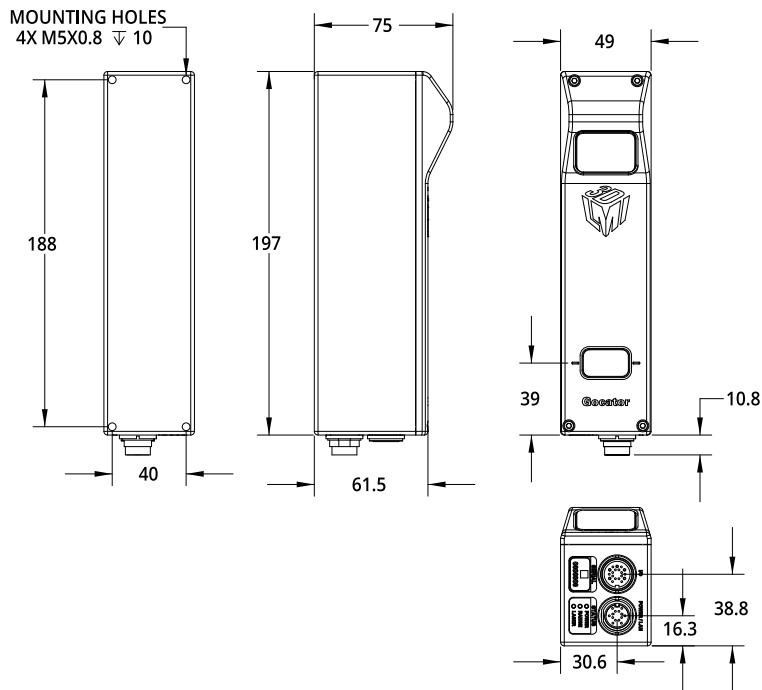

**Envelope**

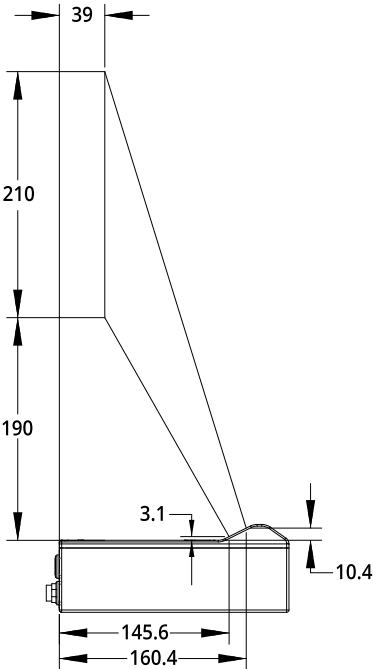

**Gocator 2350**

**Field of View / Measurement Range**

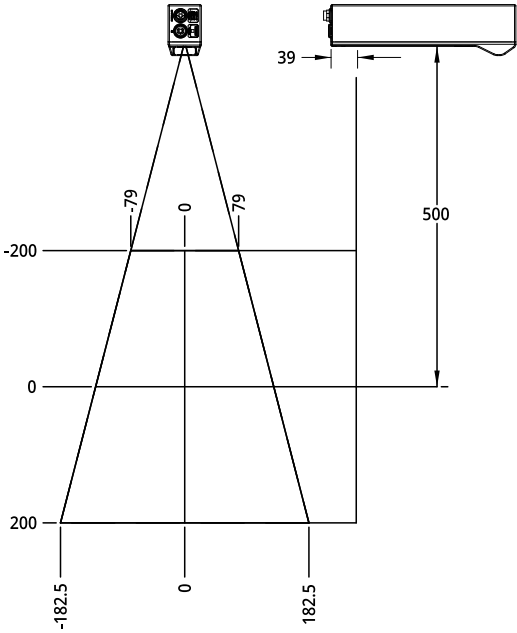

## Dimensions

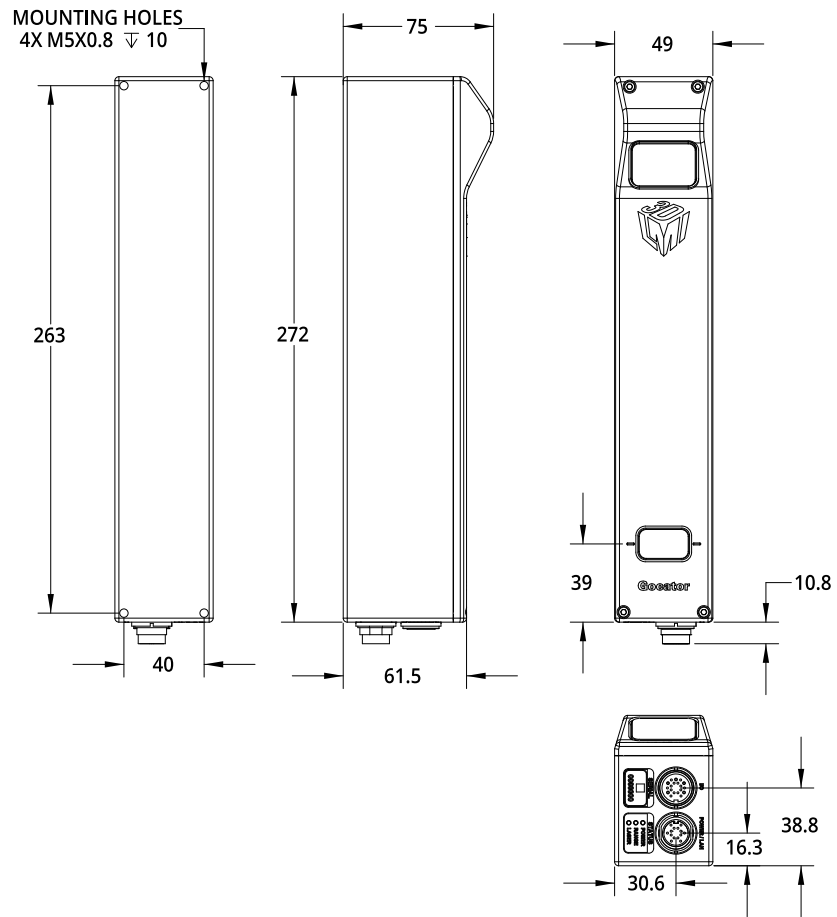

## Envelope

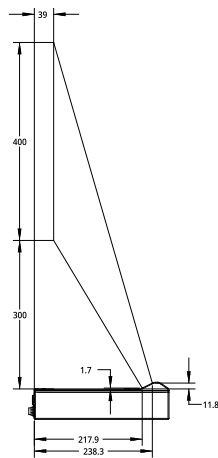

# Gocator 2370

## Field of View / Measurement Range

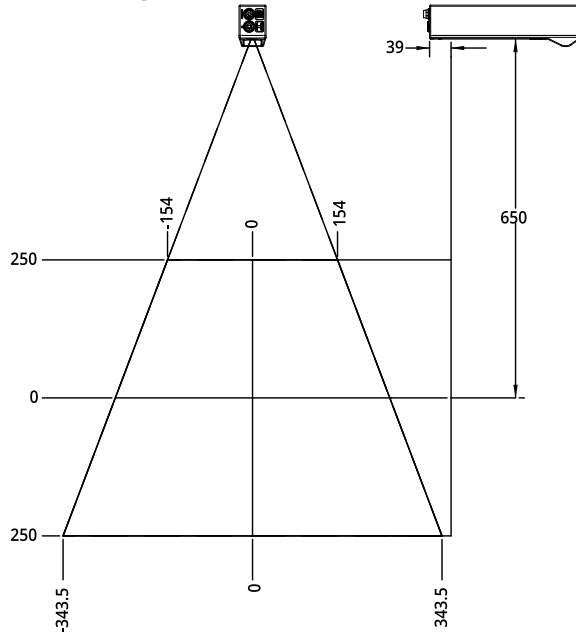

## Dimensions

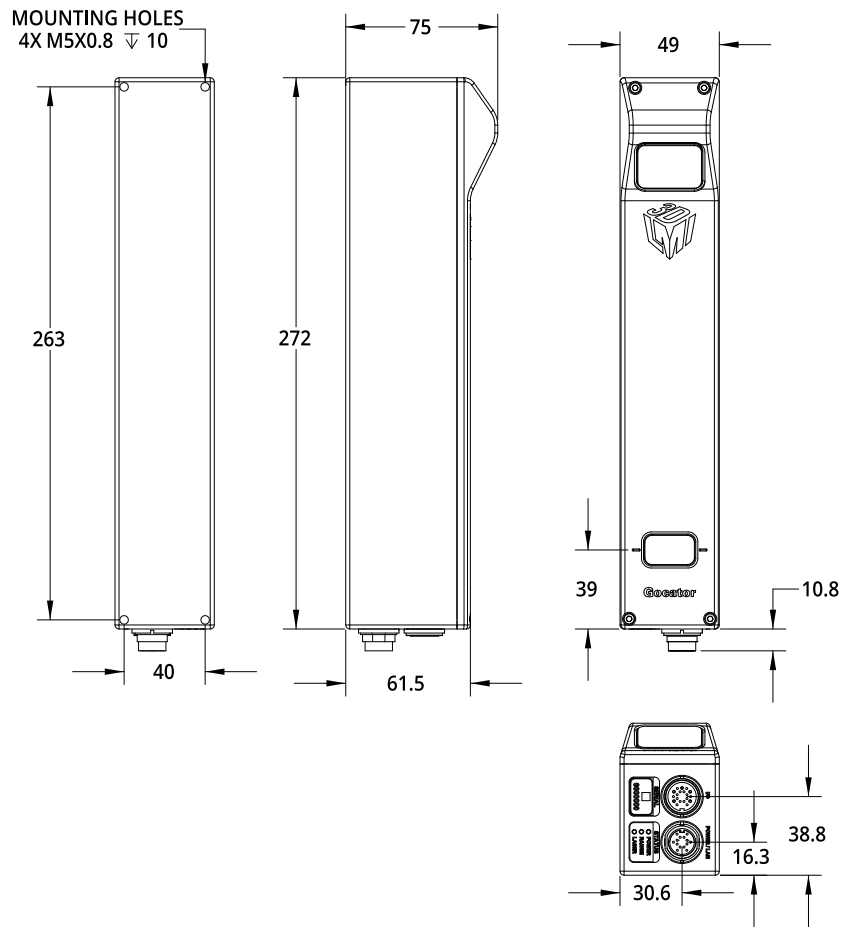

**Envelope**

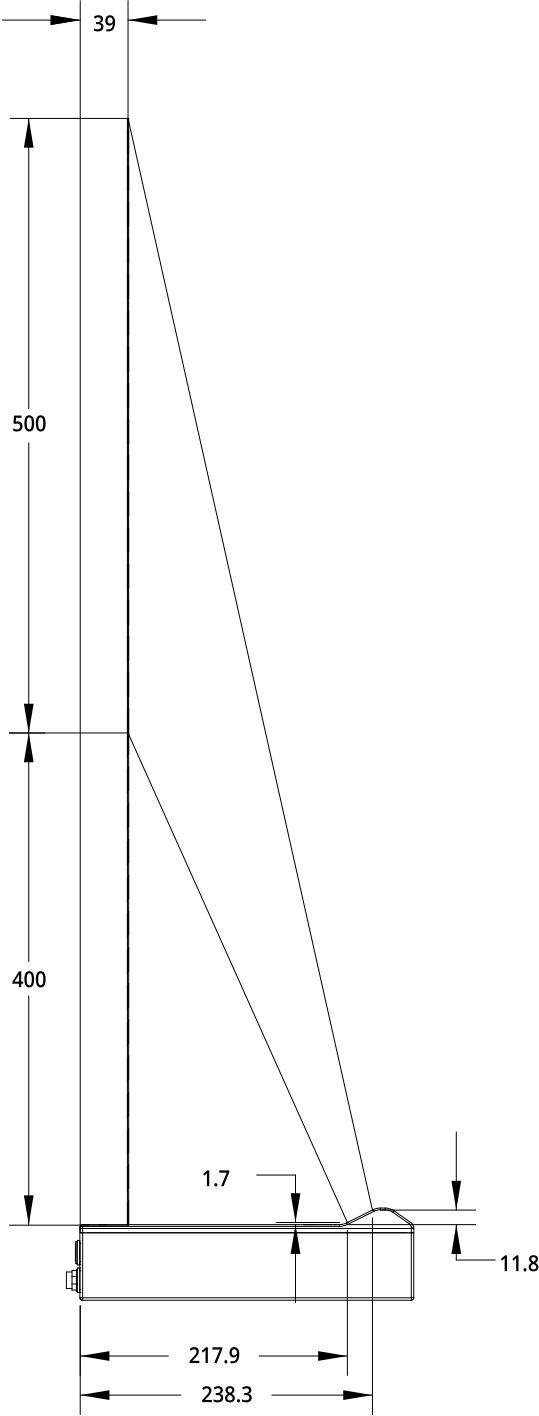



Envelope

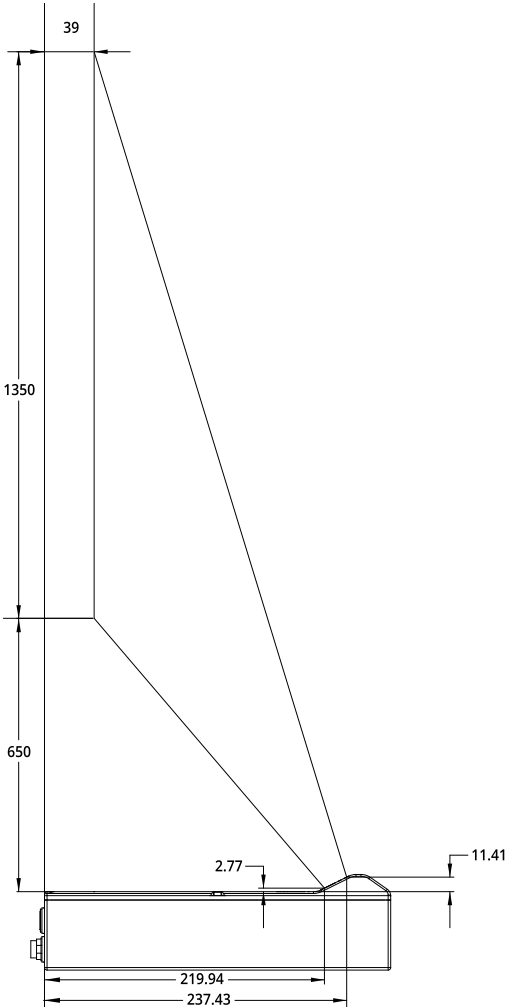

# Gocator 2380

## Field of View / Measurement Range

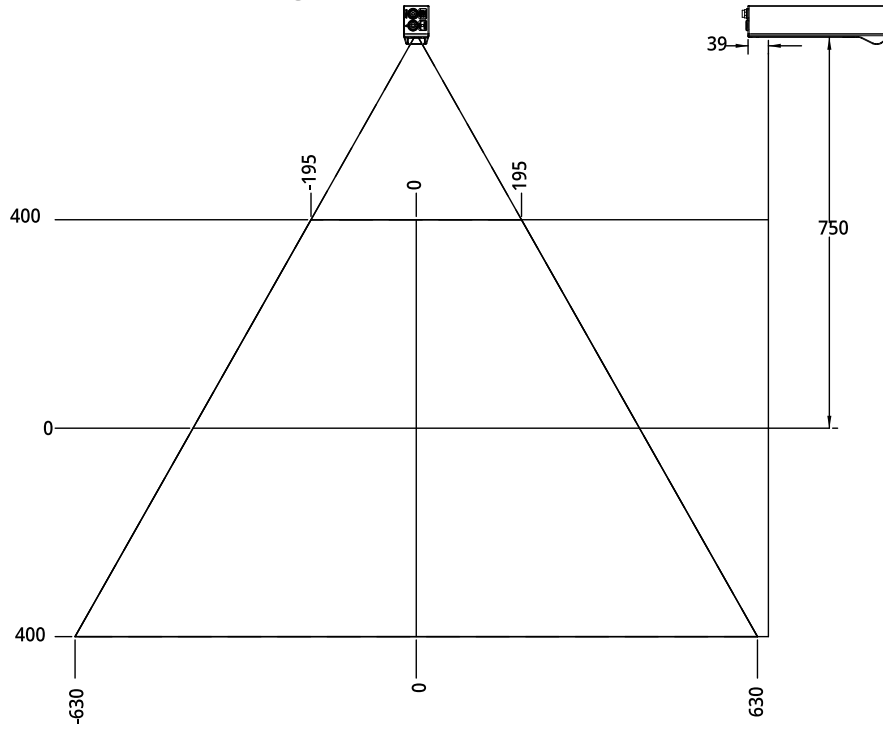

## Dimensions

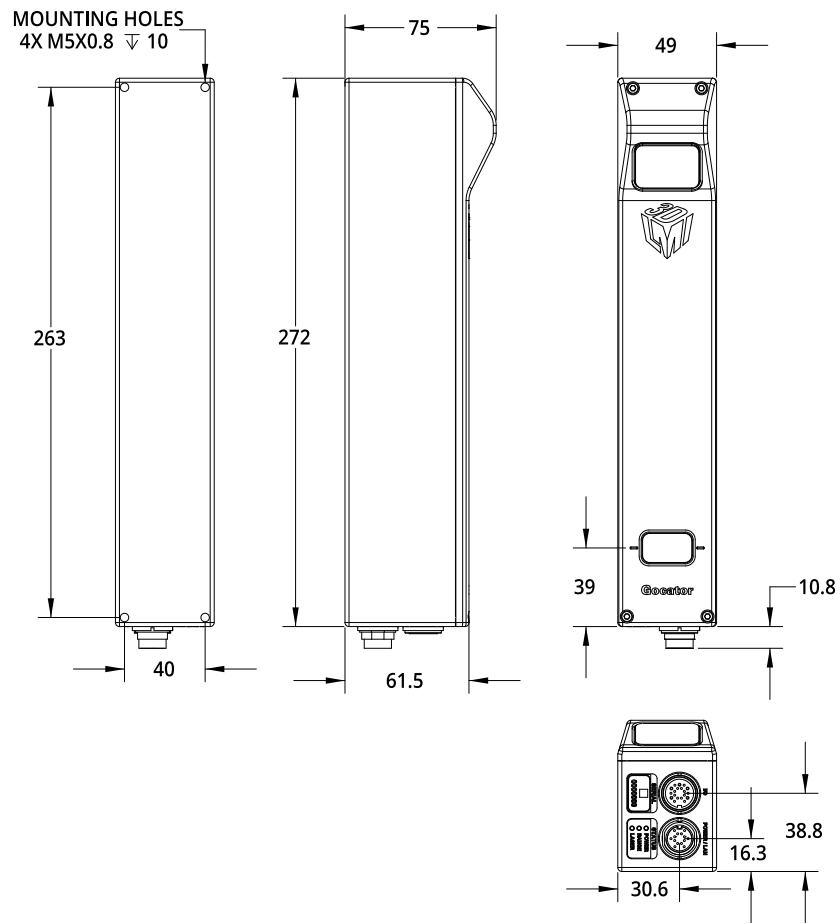

**Envelope**

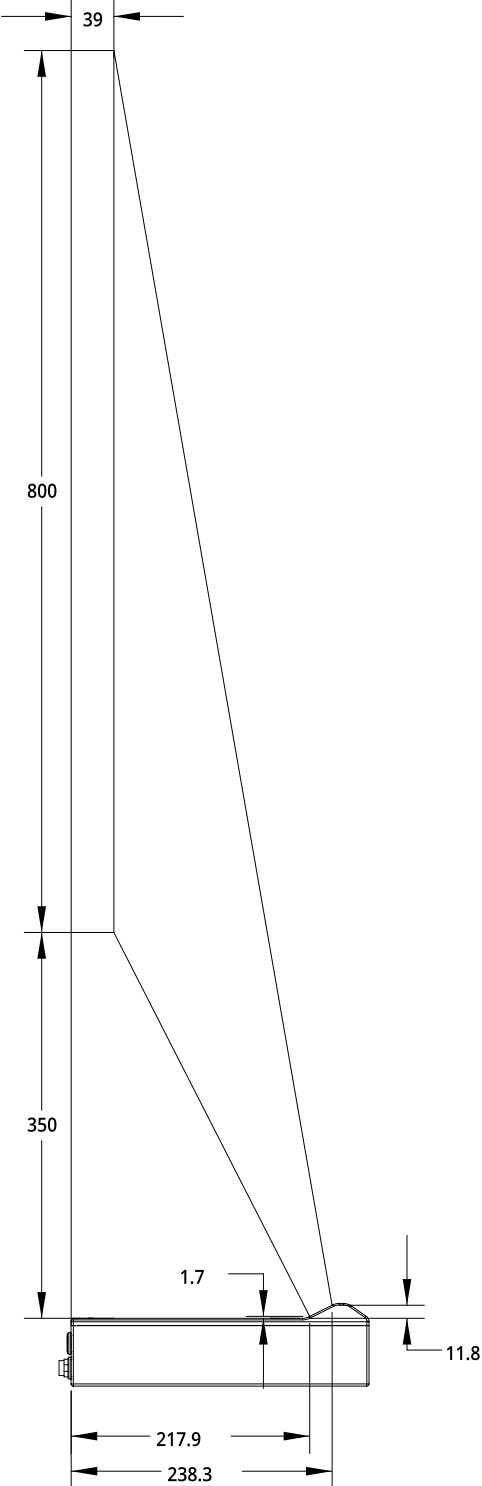

# Gocator 2000 I/O Connector

The Gocator 20x0 I/O connector is a 19 pin, M16 style connector that provides power input, laser safety input, digital input, digital output, serial output, and analog output signals.

 This connector is rated IP67 only when a cable is connected or when a protective cap is used.

This section defines the electrical specifications for Gocator I/O Connector pins, organized by function.

## Gocator I/O Connector Pins

Function	Pin	Lead Color on Cordset
DC_24-48V	1	(White Green & Black) and (Green Black)
Serial_out+	2	White
Serial_out-	3	Brown
Trigger_in+	4	Grey
Safety_in+	5	Blue/Black
Analog_out-	6	(Yellow) & (Maroon/White)
Safety_in-	7	White/Blue & Black
Trigger_in-	8	Pink
Encoder_B+	9	Black
Encoder_B-	10	Violet
GND_0V	11	(White/Orange & Black) & (Orange/Black)
Encoder_A+	12	(White/Brown) & Black
Out_1+ (Digital Output 0)	13	Red
Out_1- (Digital Output 0)	14	Blue
Analog_out1+	15	Green
Unused	16	Maroon
Out_2+ (Digital Output 1)	17	Tan
Out_2- (Digital Output 1)	18	Orange
Encoder_A-	19	Brown/Black

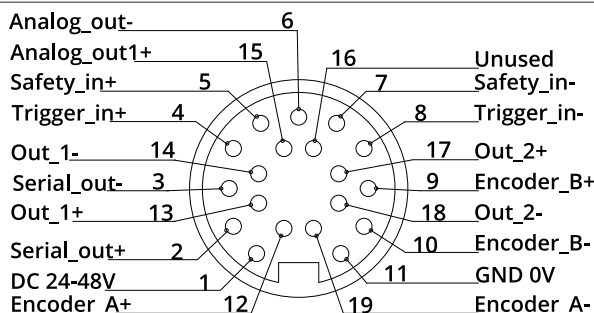

View: Looking into the connector **on** the sensor



This connector has the same number of pins as the Gocator 2300 I/O connector. You must make sure that this pinout is used for Gocator 2000 sensors only.

## Grounding Shield

The grounding shield should be mounted to the earth ground.

## Power

Positive voltage is applied to DC\_24-48V. See *Gocator 2000 Series* (page 322) for the sensor's power requirement. Ground is applied to GND\_0VDC.

### Power requirements

Function	Pins	Min	Max
DC_24-48V	1	24 V	48 V
GND_0VDC	11	0 V	0 V

## Laser Safety Input

The Safety\_in+ signal should be connected to a voltage source in the range listed below. The Safety\_in- signal should be connected to the ground/common of the source supplying the Safety\_in+.

### Laser safety requirements

Function	Pins	Min	Max
Safety_in+	5	24 V	48 V
Safety_in-	7	0 V	0 V



Confirm the wiring of Safety\_in- before starting the sensor. Wiring DC\_24-48V into Safety\_in- may damage the sensor.

## Digital Outputs

Each Gocator sensor has two optically isolated outputs. Both outputs are open collector and open emitter, this allows a variety of power sources to be connected and a variety of signal configurations.

Out\_1 (Collector – Pin 13 and Emitter – Pin 14) and Out\_2 (Collector – Pin 17 and Emitter Pin 18) are independent and therefore V+ and GND are not required to be the same.

Function	Pins	Max Collector Current	Max Collector-Emitter Voltage	Min Pulse Width
Out_1	13, 14	40 mA	70 V	20 us
Out_2	17, 18	40 mA	70 V	20 us

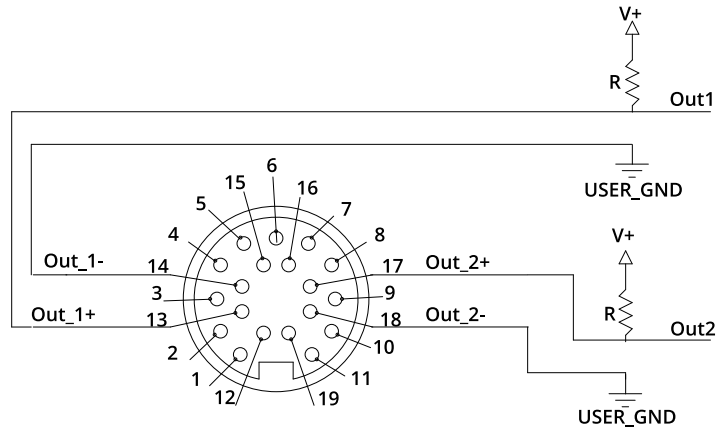

The resistors shown above are calculated by  $R = (V+) / 2.5\text{mA}$ .

The size of the resistors is determined by power  $= (V+)^2 / R$ .

## Inverting Outputs

To invert an output, connect a resistor between ground and Out\_1- or Out\_2- and connect Out\_1+ or Out\_2+ to the supply voltage. Take the output at Out\_1- or Out\_2-. The resistor selection is the same as what is shown above.

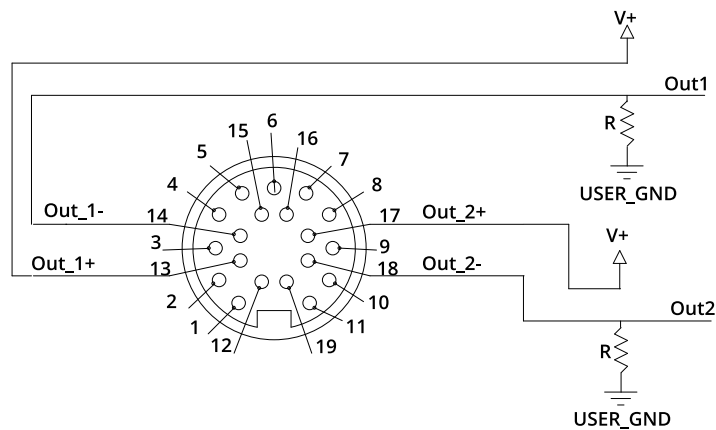

## Digital Inputs

Every Gocator sensor has a single optically isolated input. To use this input without an external resistor, supply 2.5 - 12 V to Pin 4 and GND to Pin 8.

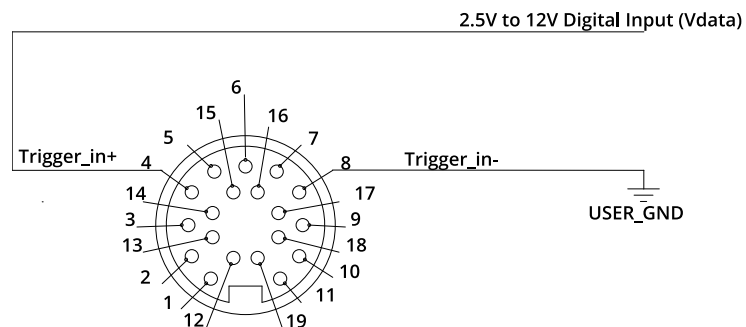

Active High

If the supplied voltage is greater than 12 V, connect an external resistor in series to Pin 4.

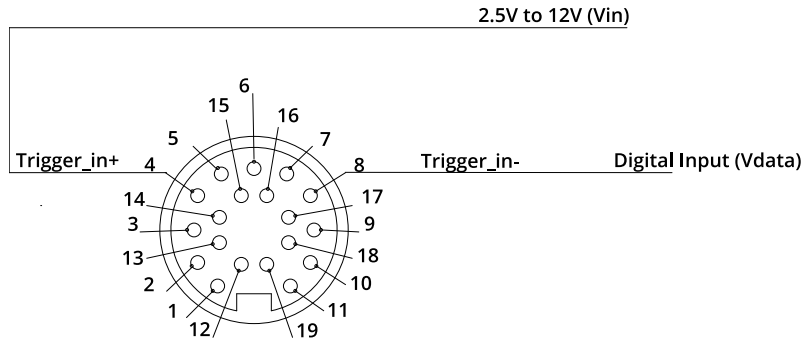

Active Low

The resistor value should be  $R = [(V_{in} - 1.2V) / 10mA] - 330$ .

To assert the signal, the digital input voltage should be set to draw a current of 3 mA to 40 mA from Trigger\_In+. The current that passes through Trigger\_In+ is  $I = (V_{in} - 1.2 - V_{data}) / 330$ . To reduce noise sensitivity, we recommend leaving a 20% margin for current variation (i.e., uses a digital input voltage that draws 4mA to 25mA).

Function	Pins	Min Voltage	Max Voltage	Min Current	Max Current	Min Pulse Width
Trigger_in	4	2.5 V	12 V	3 mA	40 mA	20 us

## Encoder Input

Encoder input is provided by an external encoder and consists of two RS-485 signals. These signals are connected to Encoder\_A and Encoder\_B.

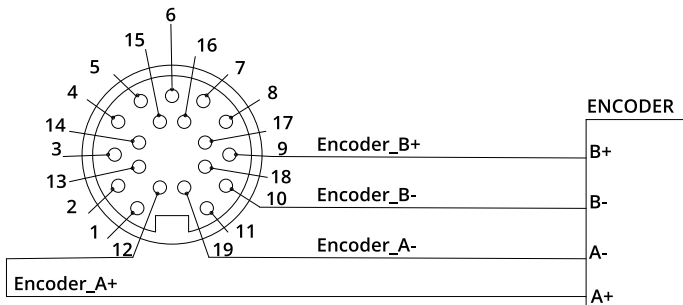

Function	Pins	Common Mode Voltage		Differential Threshold Voltage			Max Data Rate
		Min	Max	Min	Typ	Max	
Encoder_A	12, 19	-7 V	12 V	-200 mV	-125 mV	-50 mV	1 MHz
Encoder_B	9, 10	-7 V	12 V	-200 mV	-125 mV	-50 mV	1 MHz

Gocator only supports differential RS485 signalling. Both + and - signals must be connected.

## Serial Output

Serial RS-485 output is connected to Serial\_out as shown below.

Function	Pins
Serial_out	2, 3

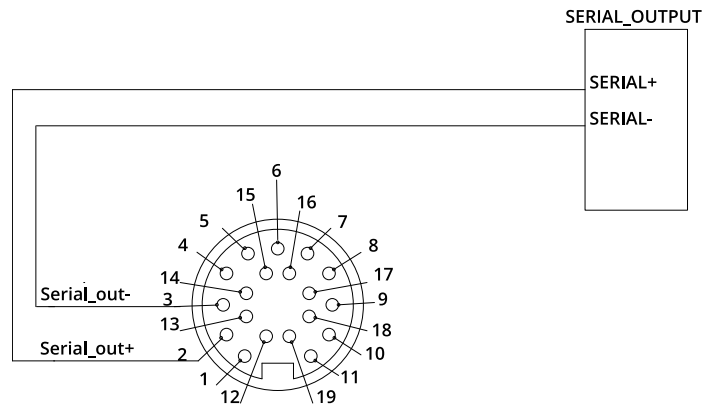

## Analog Output

The Sensor I/O Connector defines one analog output interface: Analog\_out1.

Function	Pins	Current Range
Analog_out1	15, 6	4 – 20 mA

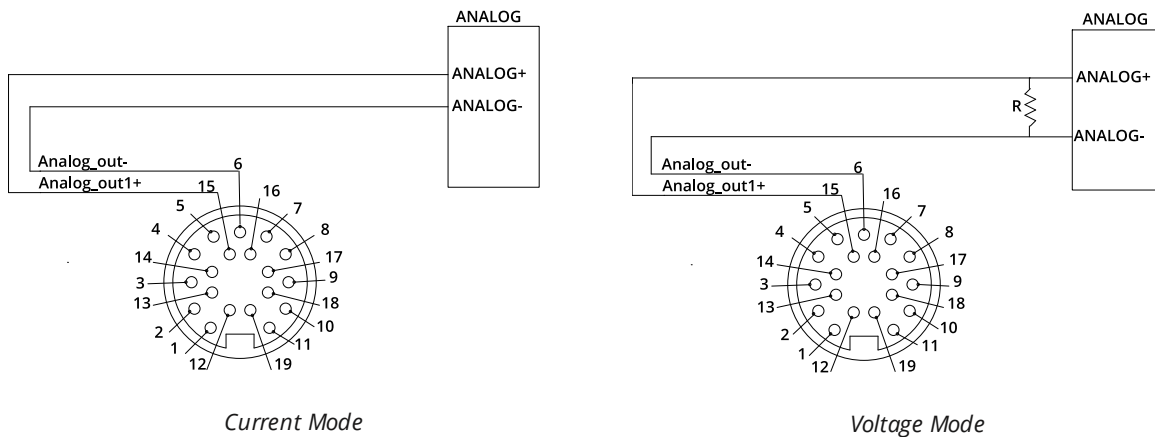

To configure for voltage output, connect a 500 Ohm ¼ Watt resistor between Analog\_out- and Analog\_out+ and measure the voltage across the resistor. To reduce the noise in the output, we recommend using a RC filter as shown below.

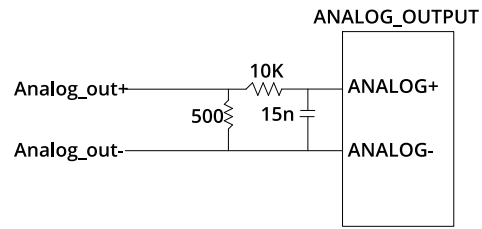

# Gocator Power/LAN Connector

The Gocator Power/LAN connector is a 14 pin, M16 style connector that provides power input, laser safety input and Ethernet.

 This connector is rated IP67 only when a cable is connected or when a protective cap is used.

This section defines the electrical specifications for Gocator Power/LAN Connector pins, organized by function.

## Gocator Power/LAN Connector Pins

Function	Pin	Lead Color on Cordset
GND_24-48V	1	White/ Orange & Black
GND_24-48V	1	Orange/ Black
DC_24-48V	2	White/ Green & Black
DC_24-48V	2	Green/ Black
Safety-	3	White/ Blue & Black
Safety+	4	Blue/ Black
Sync+	5	White/ Brown & Black
Sync-	6	Brown/ Black
Ethernet MX1+	7	White/ Orange
Ethernet MX1-	8	Orange
Ethernet MX2+	9	White/ Green
Ethernet MX2-	10	Green
Ethernet MX3-	11	White/ Blue
Ethernet MX3+	12	Blue
Ethernet MX4+	13	White/ Brown
Ethernet MX4-	14	Brown

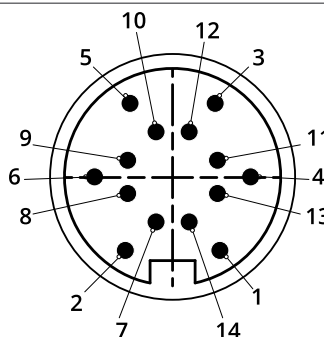

View: Looking into the connector **on** the sensor

Two wires are connected to the ground and power pins.

## Grounding Shield

The grounding shield should be mounted to the earth ground.

## Power

Positive voltage is applied to DC\_24-48V. See *Gocator 2300 Series* (page 336) for the sensor's power requirement. Ground is applied to GND\_24-48VDC.

### *Power requirements*

Function	Pins	Min	Max
DC_24-48V	2	24 V	48 V
GND_24-48VDC	1	0 V	0 V

## Laser Safety Input

The Safety\_in+ signal should be connected to a voltage source in the range listed below. The Safety\_in- signal should be connected to the ground/common of the source supplying the Safety\_in+.

### *Laser safety requirements*

Function	Pins	Min	Max
Safety_in+	4	24 V	48 V
Safety_in-	3	0 V	0 V



Confirm the wiring of Safety\_in- before starting the sensor. Wiring DC\_24-48V into Safety\_in- may damage the sensor.

# Gocator 2300 I/O Connector

The Gocator 2300 I/O connector is a 19 pin, M16 style connector that provides encoder, digital input, digital outputs, serial output, and analog output signals.

 This connector is rated IP67 only when a cable is connected or when a protective cap is used.

This section defines the electrical specifications for Gocator 2300 I/O Connector pins, organized by function.

## Gocator I/O Connector Pins

Function	Pin	Lead Color on Cordset
Trigger_in+	1	Grey
Trigger_in-	2	Pink
Out_1+ (Digital Output 0)	3	Red
Out_1- (Digital Output 0)	4	Blue
Out_2+ (Digital Output 1)	5	Tan
Out_2- (Digital Output 1)	6	Orange
Encoder_A+	7	White/Brown & Black
Encoder_A-	8	Brown / Black
Encoder_B+	9	Black
Encoder_B-	10	Violet
Encoder_Z+	11	White/Green & Black
Encoder_Z-	12	Green / Black
Serial_out+	13	White
Serial_out-	14	Brown
Reserved	15	Blue / Black
Reserved	16	White / Blue & Black
Analog_out+	17	Green
Analog_out-	18	Yellow & Maroon/ White
Reserved	19	Maroon

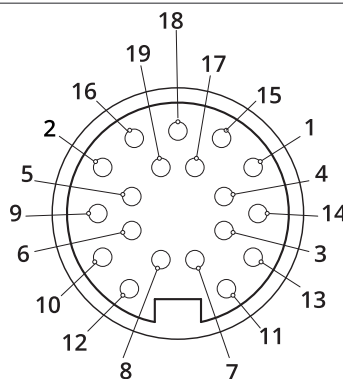

View: Looking into the connector **on** the sensor

 This connector has the same number of pins as the Gocator 2000 I/O connector. You must make sure that this pinout is used for Gocator 2300 sensors only.

## Grounding Shield

The grounding shield should be mounted to the earth ground.

## Digital Outputs

Each Gocator sensor has two optically isolated outputs. Both outputs are open collector and open emitter, this allows a variety of power sources to be connected and a variety of signal configurations.

Out\_1 (Collector – Pin 3 and Emitter – Pin 4) and Out\_2 (Collector – Pin 5 and Emitter Pin 6) are independent and therefore V+ and GND are not required to be the same.

Function	Pins	Max Collector Current	Max Collector-Emitter Voltage	Min Pulse Width
Out_1	3, 4	40 mA	70 V	20 us
Out_2	5, 6	40 mA	70 V	20 us

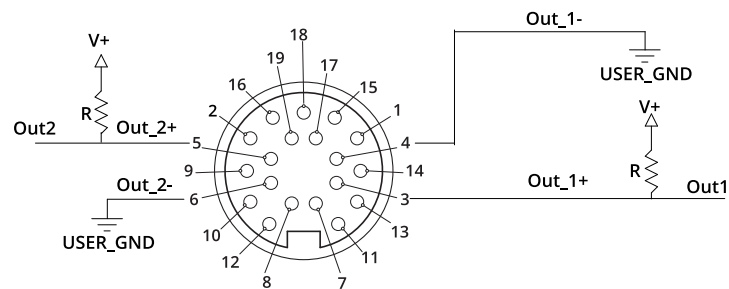

The resistors shown above are calculated by  $R = (V+) / 2.5 \text{ mA}$ .

The size of the resistors is determined by power =  $(V+)^2 / R$ .

## Inverting Outputs

To invert an output, connect a resistor between ground and Out\_1- or Out\_2- and connect Out\_1+ or Out\_2+ to the supply voltage. Take the output at Out\_1- or Out\_2-. The resistor selection is the same as what is shown above.

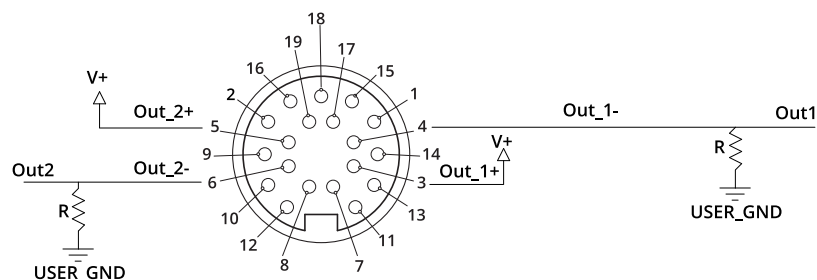

## Digital Inputs

Every Gocator sensor has a single optically isolated input. To use this input without an external resistor, supply 3.3 - 24 V to Pin 1 and GND to Pin 2.

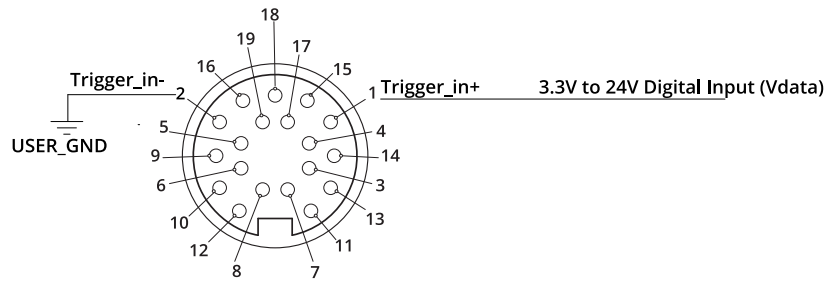

Active High

If the supplied voltage is greater than 24 V, connect an external resistor in series to Pin 1. The resistor value should be  $R = [(V_{in} - 1.2V) / 10mA] - 680$ .

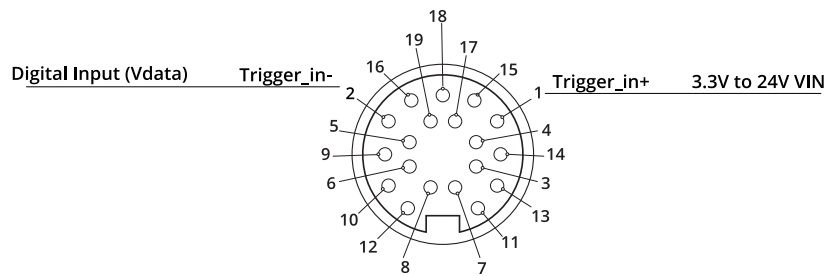

Active Low

To assert the signal, the digital input voltage should be set to draw a current of 3 mA to 40 mA from Trigger\_In+. The current that passes through Trigger\_In+ is  $I = (V_{in} - 1.2 - V_{data}) / 680$ . To reduce noise sensitivity, we recommend leaving a 20% margin for current variation (i.e., uses a digital input voltage that draws 4mA to 25mA).

Function	Pins	Min Voltage	Max Voltage	Min Current	Max Current	Min Pulse Width
Trigger_in	1, 2	3.3 V	24 V	3 mA	40 mA	20 us

## Encoder Input

Encoder input is provided by an external encoder and consists of three RS-485 signals. These signals are connected to Encoder\_A, Encoder\_B, and Encoder\_Z.

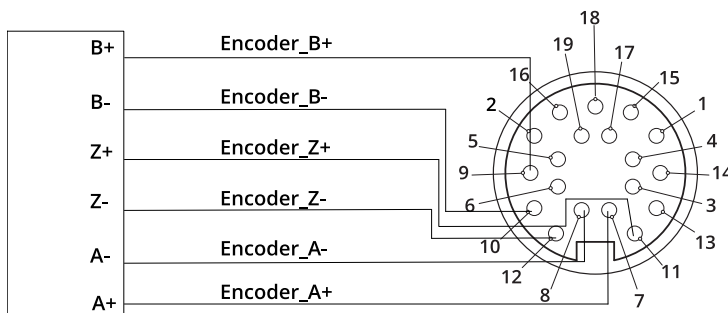

Function	Pins	Common Mode Voltage		Differential Threshold Voltage			Max Data Rate
		Min	Max	Min	Typ	Max	
Encoder_A	7, 8	-7 V	12 V	-200 mV	-125 mV	-50 mV	1 MHz
Encoder_B	9, 10	-7 V	12 V	-200 mV	-125 mV	-50 mV	1 MHz
Encoder_Z	11, 12	-7 V	12 V	-200 mV	-125 mV	-50 mV	1 MHz

 Gocator only supports differential RS485 signalling. Both + and - signals must be connected.

 Encoders are normally specified in *pulses* per revolution, where each pulse is made up of the four quadrature *signals* (A+ / A- / B+ / B-). Because Gocator reads each of the four quadrature signals, you should choose an encoder accordingly, given the resolution required for your application.

## Serial Output

Serial RS-485 output is connected to Serial\_out as shown below.

Function	Pins
Serial_out	13, 14

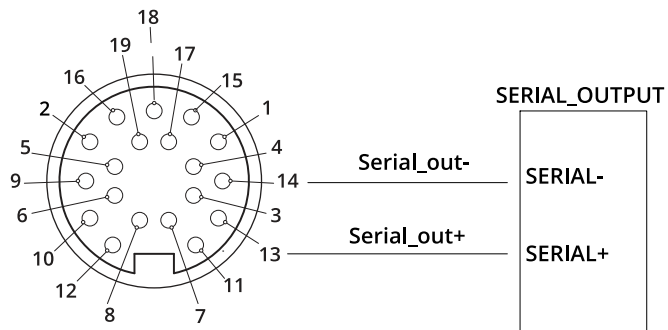

## Analog Output

The Sensor I/O Connector defines one analog output interface: Analog\_out.

Function	Pins	Current Range
Analog_out	17, 18	4 – 20 mA

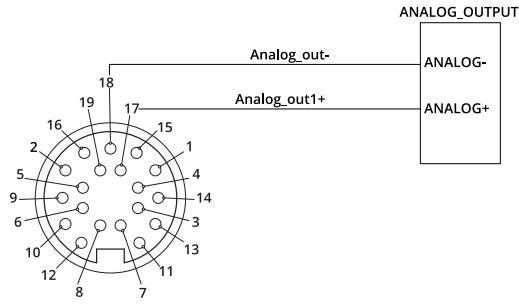

*Current Mode*

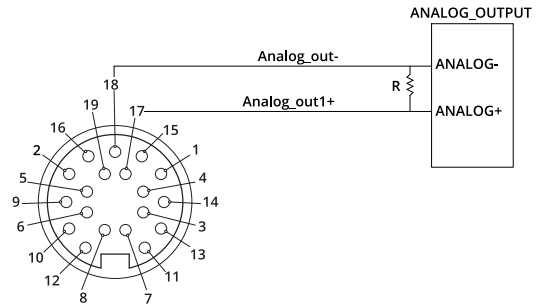

*Voltage Mode*

To configure for voltage output, connect a 500 Ohm  $\frac{1}{4}$  Watt resistor between Analog\_out+ and Analog\_out- and measure the voltage across the resistor. To reduce the noise in the output, we recommend using an RC filter as shown below.

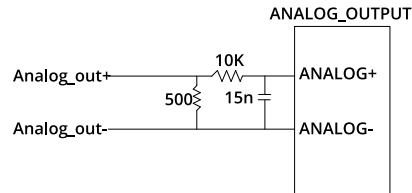

# Master 100

The Master 100 accepts connections for power, safety, and encoder, and provides digital output.

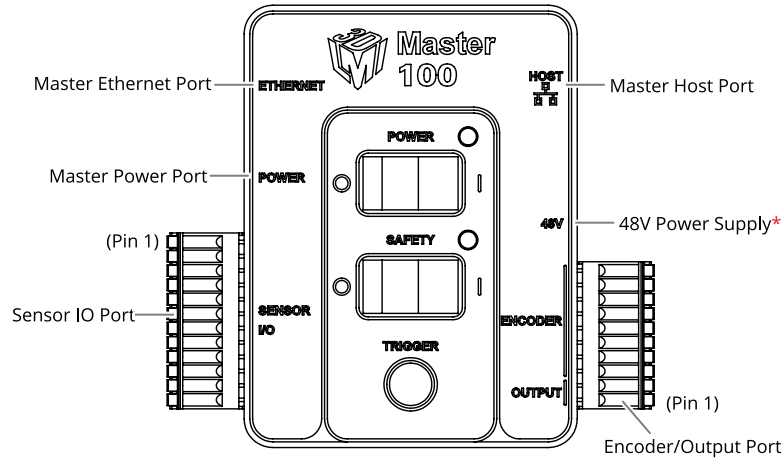

 \*Contact LMI for information regarding this type of power supply.

Connect the Master Power port to the Gocator's Power/LAN connector using the Gocator Power/LAN to Master cordset. Connect power RJ45 end of the cordset to the Master Power port. The Ethernet RJ45 end of the cordset can be connected directly to the Ethernet switch, or connect to the Master Ethernet port. If the Master Ethernet port is used, connect the Master Host port to the Ethernet switch with a CAT5e Ethernet cable.

To use encoder and digital output, wire the Master's Gocator Sensor I/O port to the Gocator IO connector using the Gocator I/O cordset.

## *Sensor I/O Port Pins*

Gocator I/O Pin	Master Pin	Conductor Color
Encoder_A+	1	White/Brown & Black
Encoder_A-	2	Brown/Black
Encoder_Z+	3	White/Green & Black
Encoder_Z-	4	Green/Black
Trigger_in+	5	Grey
Trigger_in-	6	Pink
Out_1-	7	Blue
Out_1+	8	Red
Encoder_B+	11	Black
Encoder_B-	12	Violet

The rest of the wires in the Gocator I/O cordset are not used.

### Encoder/Output Port Pins

Function	Pin
Output_1+ (Digital Output 0)	1
Output_1- (Digital Output 0)	2
Encoder_Z+	3
Encoder_Z-	4
Encoder_A+	5
Encoder_A-	6
Encoder_B+	7
Encoder_B-	8
Encoder_GND	9
Encoder_5V	10

## Master 100 Dimensions

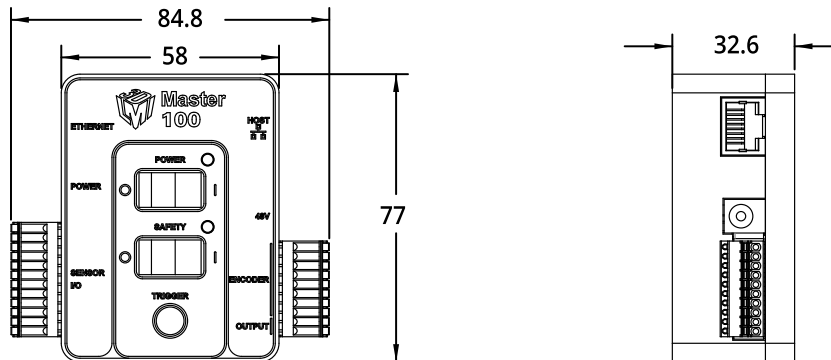

# Master 200

The Master 200 accepts I/O connections for power, safety, encoder, serial output, analog output, digital output, as well as digital input, and distributes these signals among 1 or 2 connected sensors.

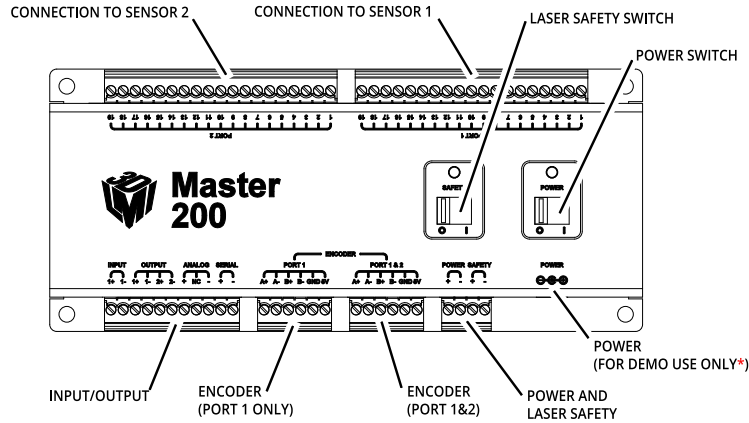

\*Contact LMI for information regarding this type of power supply.

When using the Master 200 with a single sensor, connect the sensor to Sensor Port 1 and connect the encoder to Encoder (Port 1 Only). When using the Master 200 with two sensors, connect the sensors to Sensor Port 1 and Sensor Port 2, and connect the encoder to Encoder (Port 1&2).

Specifications for the Master 200 input, output, analog, serial, encoder, power (using a single sensor), and safety signals are identical to the specifications for the Gocator I/O Connector. Power required for 2 sensors is DC\_24 - 48V @ 20 Watts.

## Sensor Port 1 and Port 2 Pins

Gocator I/O Pin	Master Pin	Conductor Color
DC_24-48V	1	(White/Green &Black) and (Green/Black)
GND_0VDC	2	(White/Orange &Black) and (Orange/Black)
Safety_in+	3	Blue/Black
Safety_in-	4	White/Blue & Black
Trigger_in+	5	Grey
Trigger_in-	6	Pink
Out_1+	7	Red
Out_1-	8	Blue
Out_2+	9	Tan
Out_2-	10	Orange
Analog_out1+	11	Green
Unused	12	Maroon

<b>Gocator I/O Pin</b>	<b>Master Pin</b>	<b>Conductor Color</b>
Analog_out-	13	(Yellow) and (Maroon/White)
Encoder_A+	14	White/Brown & Black
Encoder_A-	15	Brown/Black
Serial_out+	16	White
Serial_out-	17	Brown
Encoder_B+	18	Black
Encoder_B-	19	Violet

#### *Input/Output Pins*

<b>Function</b>	<b>Pin</b>
Input+	1
Input-	2
Output_1+ (Digital Output 0)	3
Output_1- (Digital Output 0)	4
Output_2+ (Digital Output 1)	5
Output_2- (Digital Output 1)	6
Analog+	7
Unused	8
Analog-	9
Serial+	10
Serial-	11

#### *Power and Safety Pin*

<b>Function</b>	<b>Pin</b>
DC_+24 to +48V	1
GND_0VDC	2
Safety+	3
Safety-	4

#### *Encoder (Port 1 Only) Pins*

<b>Function</b>	<b>Pin</b>
Encoder_A+	1
Encoder_A-	2
Encoder_B+	3
Encoder_B-	4
Encoder_0V	5
Encoder_5V	6

*Encoder (Port 1&2) Pins*

Function	Pin
Encoder_A+	1
Encoder_A-	2
Encoder_B+	3
Encoder_B-	4
Encoder_0V	5
Encoder_5V	6

## Master 200 Dimensions

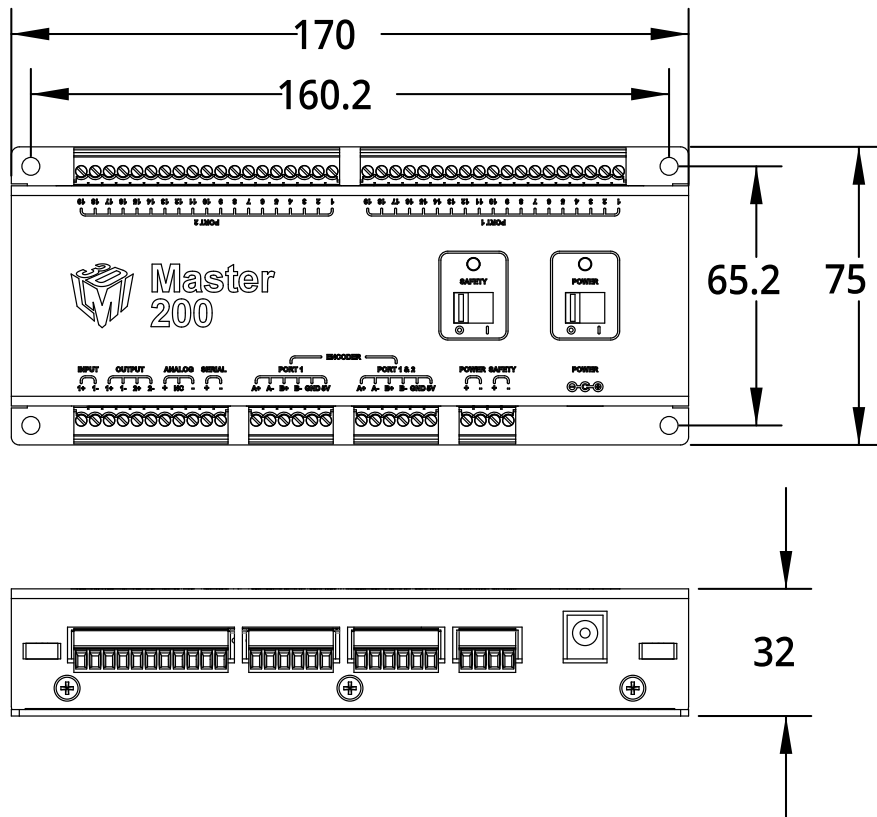

# Master 400/800

The Master 400/800 provides sensor power and safety interlock, and broadcasts system-wide synchronization information (i.e., time, encoder count, encoder index, and digital I/O states) to all devices on a sensor network.

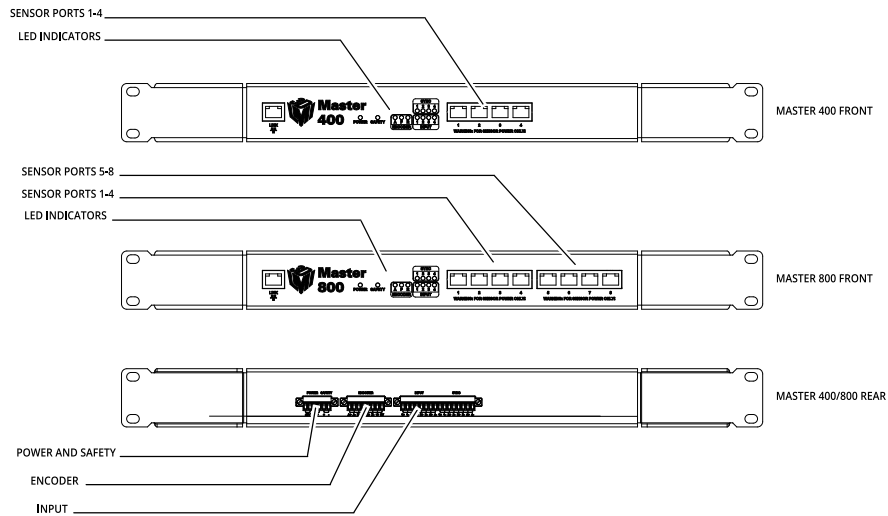

## Power and Safety (6 pin connector)

Function	Pin
+48VDC	1
+48VDC	2
GND(48VDC)	3
GND(48VDC)	4
Safety Control+	5
Safety Control-	6

 The +48VDC power supply must be isolated from AC ground. This means that AC ground and DC ground are not connected.

 The Safety Control requires a voltage differential 12VDC to 48VDC across the pin to enable the laser.

## Digital Input (16 pin connector)

Function	Pin
Input 1	1
Input 1 GND	2
Reserved	3
Reserved	4
Reserved	5

Function	Pin
Reserved	6
Reserved	7
Reserved	8
Reserved	9
Reserved	10
Reserved	11
Reserved	12
Reserved	13
Reserved	14
Reserved	15
Reserved	16



This connector does not need to be wired up for proper operation.

#### *Encoder (8 pin connector)*

Function	Pin
Encoder_A+	1
Encoder_A-	2
Encoder_B+	3
Encoder_B-	4
Encoder_Z+	5
Encoder_Z-	6
GND	7
+5VDC	8

## Master 400/800 Electrical Specifications

### *Electrical Specifications for Master 400/800*

<b>Master 400 / 800</b>	
Power Supply Voltage	+48VDC
Power Supply current (Max.)	10A
Power Draw (Min.)	15W
Safety Voltage	+12 to +48VDC
Encoder signal voltage range	RS485 Differential
Digital input voltage range	Logical LOW: 0 VDC to +0.1VDC Logical HIGH: +11 VDC to +22.5VDC



When using a Master 400/800, its chassis must be well grounded.

☐ The +48VDC power supply must be isolated from AC ground. This means that AC ground and DC ground are not connected.

☐ The Power Draw specification is based on a Master with no sensors attached. Every sensor has its own power requirements which need to be considered when calculating total system power requirements.

## Master 400/800 Dimensions

The dimensions of Master 400 and Master 800 are the same.

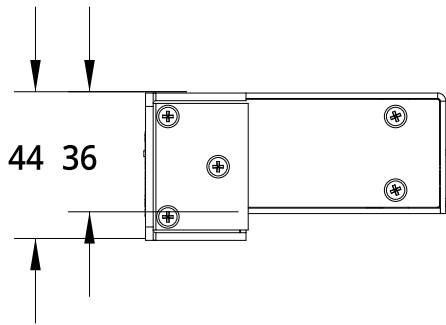
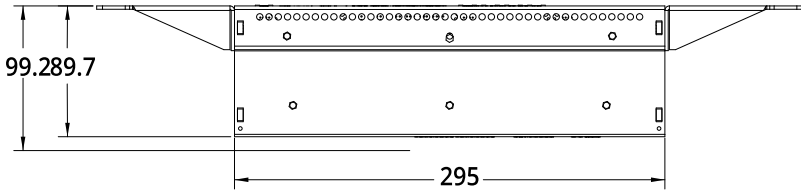
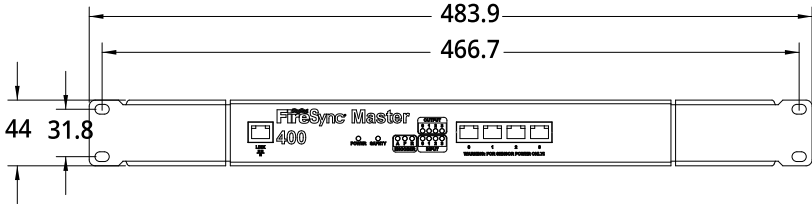

# Master 1200/2400

The Master 1200/2400 provides sensor power and safety interlock, and broadcasts system-wide synchronization information (i.e., time, encoder count, encoder index, and digital I/O states) to all devices on a sensor network.

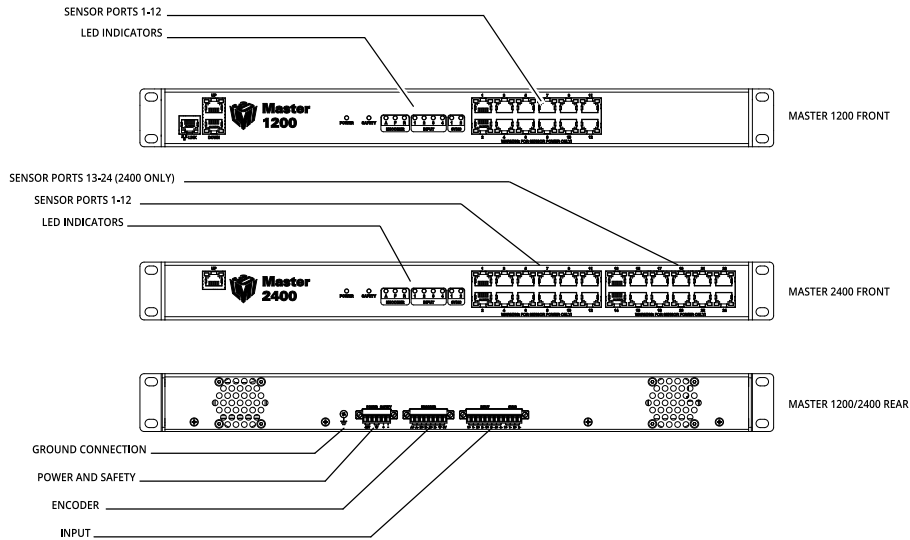

## Power and Safety (6 pin connector)

Function	Pin
+48VDC	1
+48VDC	2
GND(48VDC)	3
GND(48VDC)	4
Safety Control+	5
Safety Control-	6

 The +48VDC power supply must be isolated from AC ground. This means that AC ground and DC ground are not connected.

 The Safety Control requires a voltage differential 12VDC to 48VDC across the pin to enable the laser.

## Digital Input (16 pin connector)

Function	Pin
Input 1	1
Input 1 GND	2
Reserved	3
Reserved	4

Function	Pin
Reserved	5
Reserved	6
Reserved	7
Reserved	8
Reserved	9
Reserved	10
Reserved	11
Reserved	12

 This connector does not need to be wired up for proper operation.

*Encoder (8 pin connector)*

Function	Pin
Encoder_A+	1
Encoder_A-	2
Encoder_B+	3
Encoder_B-	4
Encoder_Z+	5
Encoder_Z-	6
GND	7
+5VDC	8

## Master 1200/2400 Electrical Specifications

*Electrical Specifications for Master 1200/2400*

Master 1200 / 2400	
Power Supply Voltage	+48VDC
Power Supply current (Max.)	10A
Power Draw (Min.)	15W
Safety Voltage	+12 to +48VDC
Encoder signal voltage range	RS485 Differential
Digital input voltage range	Logical LOW: 0 VDC to +0.1VDC Logical HIGH: +3.5 VDC to +6.5VDC

 When using a Master 1200/2400, its chassis must be well grounded.

 The +48VDC power supply must be isolated from AC ground. This means that AC ground and DC ground are not connected.



The Power Draw specification is based on a Master with no sensors attached. Every sensor has its own power requirements which need to be considered when calculating total system power requirements.

## Master 1200/2400 Dimensions

The dimensions of Master 1200 and Master 2400 are the same.

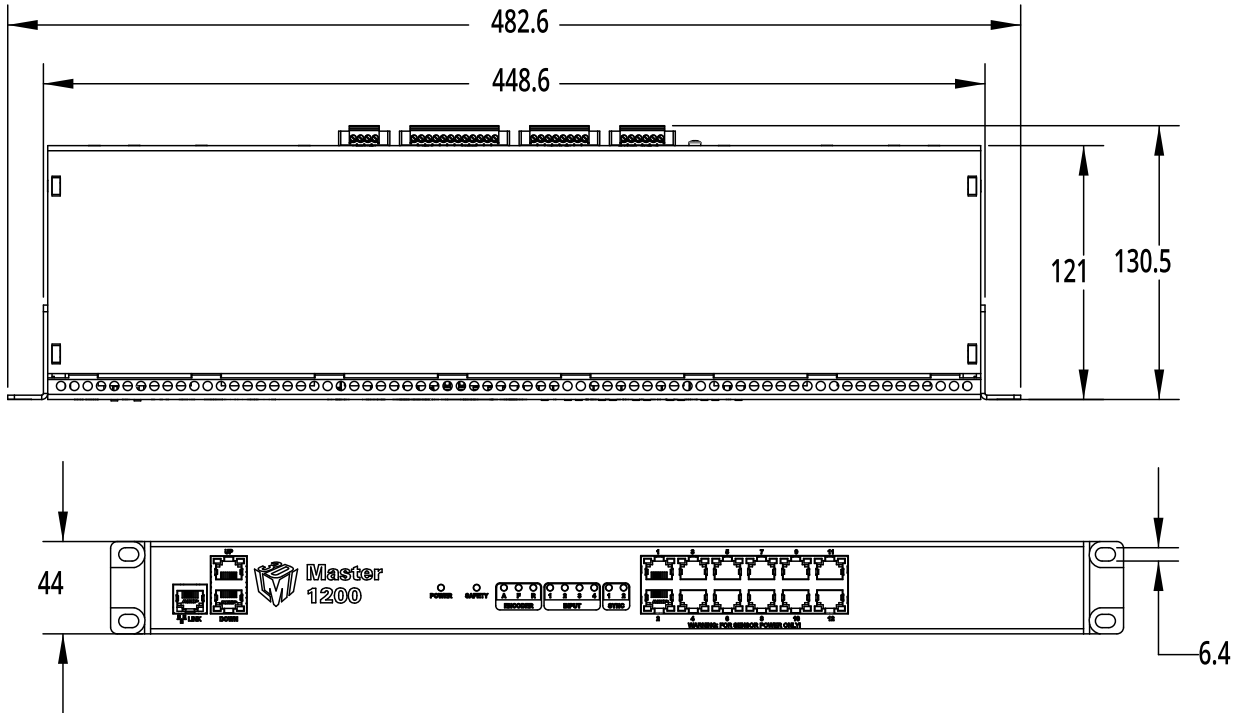

# Parts and Accessories

## Gocator Part Number Legend

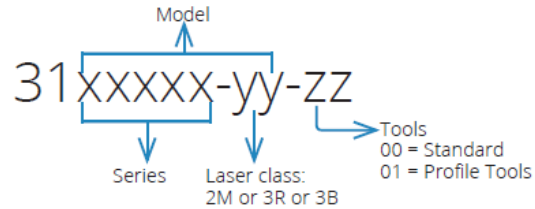

### Gocator 2000 Sensors

Description	Part Number
Gocator 2020 with Class 2M laser (2020-2M)	312020-2M-00
Gocator 2030 with Class 2M laser (2030-2M)	312030-2M-00
Gocator 2040 with Class 3R laser (2040-3R)	312040-3R-00
Gocator 2050 with Class 3R laser (2050-3R)	312050-3R-00
Gocator 2070 with Class 3B laser (2070-3B)	312070-3B-00
Gocator 2075 with Class 3B laser (2075-3B)	312075-3B-00
Gocator 2080 with Class 3B laser (2080-3B)	312080-3B-00
Standard tools	31XXXX-YY-00
Measurement tools	31XXXX-YY-01

### Gocator 2300 Sensors

Description	Part Number
Gocator 2330 with Class 2M laser (2330-2M)	312330A-2M-00
with Class 3R laser (2330-3R)	312330A-3R-00
with Class 3B laser (2330-3B)	312330A-3B-00
Gocator 2340 with Class 3R laser (2340-3R)	312340A-3R-00
with Class 3B laser (2340-3B)	312340A-3B-00
Gocator 2350 with Class 3R laser (2350-3R)	312350A-3R-00
with Class 3B laser (2350-3B)	312350A-3B-00
Gocator 2370 with Class 3B laser (2370-3B)	312370A-3B-00
Gocator 2375 with Class 3B laser (2375-3B)	312375A-3B-00
Gocator 2380 with Class 3B laser (2380-3B)	312380A-3B-00
Standard tools	31XXXXX-YY-00
Measurement tools	31XXXXX-YY-01

### *Masters*

<b>Description</b>	<b>Part Number</b>
Master 100 - for single sensor (development only)	30705
Master 200 - for networking up to 2 sensors	30704
Master 400 - for networking up to 4 sensors	30680
Master 800 - for networking up to 8 sensors	30681
Master 1200 - for networking up to 12 sensors	30649
Master 2400 - for networking up to 24 sensors	30650

### *Cordsets*

<b>Description</b>	<b>Part Number</b>
2m I/O cordset, open wire end	30864-2m
5m I/O cordset, open wire end	30862
10m I/O cordset, open wire end	30863
15m I/O cordset, open wire end	30864-15m
20m I/O cordset, open wire end	30864-20m
25m I/O cordset, open wire end	30864-25m
2m Power and Ethernet cordset, 1x open wire end, 1x RJ45 end	30861-2m
5m Power and Ethernet cordset, 1x open wire end, 1x RJ45 end	30859
10m Power and Ethernet cordset, 1x open wire end, 1x RJ45 end	30860
15m Power and Ethernet cordset, 1x open wire end, 1x RJ45 end	30861-15m
20m Power and Ethernet cordset, 1x open wire end, 1x RJ45 end	30861-20m
25m Power and Ethernet cordset, 1x open wire end, 1x RJ45 end	30861-25m
2m Power and Ethernet to Master cordset, 2x RJ45 ends	30858-2m
5m Power and Ethernet to Master cordset, 2x RJ45 ends	30856
10m Power and Ethernet to Master cordset, 2x RJ45 ends	30857
15m Power and Ethernet to Master cordset, 2x RJ45 ends	30858-15m
20m Power and Ethernet to Master cordset, 2x RJ45 ends	30858-20m
25m Power and Ethernet to Master cordset, 2x RJ45 ends	30858-25m
5m shielded Gocator 20x0 Power and I/O cordset, open wire end	30737
10m shielded Gocator 20x0 Power and I/O cordset, open wire end	30738
5m shielded Gocator 20x0 Ethernet cordset, RJ45 end	30741
10m shielded Gocator 20x0 Ethernet cordset, RJ45 end	30742
5m shielded Gocator 20x0 I/O to Master cordset, RJ45 end	30739
10m shielded Gocator 20x0 I/O to Master cordset, RJ45 end	30740

### *Accessories*

<b>Description</b>	<b>Part Number</b>
Calibration Disk, 40mm	30727
Calibration Disk, 100mm	30728

Contact LMI for information on creating cordsets with custom length or connector orientation. The maximum cordset length is 60 m.

# Return Policy

## **Return Policy**

Before returning the product for repair (warranty or non-warranty) a Return Material Authorization (RMA) number must be obtained from LMI. Please call LMI to obtain this RMA number.

Carefully package the sensor in its original shipping materials (or equivalent) and ship the sensor prepaid to your designated LMI location. Please ensure that the RMA number is clearly written on the outside of the package. Inside the return shipment, include the address you wish the shipment returned to, the name, email and telephone number of a technical contact (should we need to discuss this repair), and details of the nature of the malfunction. For non-warranty repairs, a purchase order for the repair charges must accompany the returning sensor.

LMI Technologies Inc. is not responsible for damages to a sensor that are the result of improper packaging or damage during transit by the courier.

# Software Licenses

Pico-C

Website:

<http://code.google.com/p/picoc/>

License:

picoc is published under the "New BSD License".

<http://www.opensource.org/licenses/bsd-license.php>

Copyright (c) 2009-2011, Zik Saleeba

All rights reserved.

Redistribution and use in source and binary forms, with or without modification, are permitted provided that the following conditions are met:

\* Redistributions of source code must retain the above copyright notice, this list of conditions and the following disclaimer.

\* Redistributions in binary form must reproduce the above copyright notice, this list of conditions and the following disclaimer in the documentation and/or other materials provided with the distribution.

\* Neither the name of the Zik Saleeba nor the names of its contributors may be used to endorse or promote products derived from this software without specific prior written permission.

THIS SOFTWARE IS PROVIDED BY THE COPYRIGHT HOLDERS AND CONTRIBUTORS "AS IS" AND ANY EXPRESS OR IMPLIED WARRANTIES, INCLUDING, BUT NOT LIMITED TO, THE IMPLIED WARRANTIES OF MERCHANTABILITY AND FITNESS FOR A PARTICULAR PURPOSE ARE DISCLAIMED. IN NO EVENT SHALL THE COPYRIGHT OWNER OR CONTRIBUTORS BE LIABLE FOR ANY DIRECT, INDIRECT, INCIDENTAL, SPECIAL, EXEMPLARY, OR CONSEQUENTIAL DAMAGES (INCLUDING, BUT NOT LIMITED TO, PROCUREMENT OF SUBSTITUTE GOODS OR SERVICES; LOSS OF USE, DATA, OR PROFITS; OR BUSINESS INTERRUPTION) HOWEVER CAUSED AND ON ANY THEORY OF LIABILITY, WHETHER IN CONTRACT, STRICT LIABILITY, OR TORT (INCLUDING NEGLIGENCE OR OTHERWISE) ARISING IN ANY WAY OUT OF THE USE OF THIS SOFTWARE, EVEN IF ADVISED OF THE POSSIBILITY OF SUCH DAMAGE.

BlowFish

Website:

<http://www.chiark.greenend.org.uk/~sgtatham/putty/licence.html>

License:

PuTTY is copyright 1997-2011 Simon Tatham.

Portions copyright Robert de Bath, Joris van Rantwijk, Delian Delchev, Andreas Schultz, Jeroen Massar, Wez Furlong, Nicolas Barry, Justin Bradford, Ben Harris, Malcolm Smith, Ahmad Khalifa, Markus Kuhn, Colin Watson, and CORE SDI S.A.

Permission is hereby granted, free of charge, to any person obtaining a copy of this software and associated documentation files (the "Software"), to deal in the Software without restriction, including without limitation the rights to use, copy, modify, merge, publish, distribute, sublicense, and/or sell copies of the Software, and to permit persons to whom the Software is furnished to do so, subject to the following conditions:

The above copyright notice and this permission notice shall be included in all copies or substantial portions of the Software.

THE SOFTWARE IS PROVIDED "AS IS", WITHOUT WARRANTY OF ANY KIND, EXPRESS OR IMPLIED, INCLUDING BUT NOT LIMITED TO THE WARRANTIES OF MERCHANTABILITY, FITNESS FOR A PARTICULAR PURPOSE AND NONINFRINGEMENT. IN NO EVENT SHALL SIMON TATHAM BE LIABLE FOR ANY CLAIM, DAMAGES OR OTHER LIABILITY, WHETHER IN AN ACTION OF CONTRACT, TORT OR OTHERWISE, ARISING FROM, OUT OF OR IN CONNECTION WITH THE SOFTWARE OR THE USE OR OTHER DEALINGS IN THE SOFTWARE.

CodeMirror

Website:

<http://codemirror.net>

License:

Copyright (C) 2011 by Marijn Haverbeke <marijnh@gmail.com>

Permission is hereby granted, free of charge, to any person obtaining a copy of this software and associated documentation files (the "Software"), to deal in the Software without restriction, including without limitation the rights to use, copy, modify, merge, publish, distribute, sublicense, and/or sell copies of the Software, and to permit persons to whom the Software is furnished to do so, subject to the following conditions:

The above copyright notice and this permission notice shall be included in all copies or substantial portions of the Software.

THE SOFTWARE IS PROVIDED "AS IS", WITHOUT WARRANTY OF ANY KIND, EXPRESS OR IMPLIED, INCLUDING BUT NOT LIMITED TO THE WARRANTIES OF MERCHANTABILITY, FITNESS FOR A PARTICULAR PURPOSE AND NONINFRINGEMENT. IN NO EVENT SHALL THE AUTHORS OR COPYRIGHT HOLDERS BE LIABLE FOR ANY CLAIM, DAMAGES OR OTHER LIABILITY, WHETHER IN AN ACTION OF CONTRACT, TORT OR OTHERWISE, ARISING FROM, OUT OF OR IN CONNECTION WITH THE SOFTWARE OR THE USE OR OTHER DEALINGS IN THE SOFTWARE.

jQuery

Website:

<http://jquery.com/>

License:

Copyright (c) 2011 John Resig, <http://jquery.com/>

Permission is hereby granted, free of charge, to any person obtaining a copy of this software and associated documentation files (the "Software"), to deal in the Software without restriction, including without limitation the rights to use, copy, modify, merge, publish, distribute, sublicense, and/or sell copies of the Software, and to permit persons to whom the Software is furnished to do so, subject to the following conditions:

The above copyright notice and this permission notice shall be included in all copies or substantial portions of the Software.

THE SOFTWARE IS PROVIDED "AS IS", WITHOUT WARRANTY OF ANY KIND, EXPRESS OR IMPLIED, INCLUDING BUT NOT LIMITED TO THE WARRANTIES OF MERCHANTABILITY, FITNESS FOR A PARTICULAR PURPOSE AND NONINFRINGEMENT. IN NO EVENT SHALL THE AUTHORS OR COPYRIGHT HOLDERS BE LIABLE FOR ANY CLAIM, DAMAGES OR OTHER LIABILITY, WHETHER IN AN ACTION OF CONTRACT, TORT OR OTHERWISE, ARISING FROM, OUT OF OR IN CONNECTION WITH THE SOFTWARE OR THE USE OR OTHER DEALINGS IN THE SOFTWARE.

Closure Library

Website:

<http://code.google.com/closure/library/index.html>

License:

Copyright 2006 The Closure Library Authors. All Rights Reserved.

Licensed under the Apache License, Version 2.0 (the "License"); you may not use this file except in compliance with the License.

You may obtain a copy of the License at <http://www.apache.org/licenses/LICENSE-2.0>

Unless required by applicable law or agreed to in writing, software distributed under the License is distributed on an "AS-IS" BASIS, WITHOUT WARRANTIES OR CONDITIONS OF ANY KIND, either express or implied. See the License for the specific language governing permissions and limitations under the License.

jQuery.CopyEvents

Website:

<http://brandonaaaron.net>

License:

Copyright (c) 2006 Brandon Aaron

Licensed under the MIT License (<http://www.opensource.org/licenses/mit-license.php>)

jQuery.history

License:

jQuery history plugin

Copyright (c) 2006 Taku Sano (Mikage Sawatari)

Licensed under the MIT License (<http://www.opensource.org/licenses/mit-license.php>)

Modified by Lincoln Cooper to add Safari support and only call the callback once during initialization for msie when no initial hash supplied. API rewrite by Lauris Bukis-Haberkorns

jQuery.mouseWheel

Website:

<http://brandonaaaron.net>

License:

Copyright (c) 2010 Brandon Aaron

Licensed under the MIT License (<http://www.opensource.org/licenses/mit-license.php>)

jQuery.scaling

Website:

<http://eric.garside.name>

License:

Scaling 1.0 - Scale any page element

Copyright (c) 2009 Eric Garside

Licensed under the MIT License (<http://www.opensource.org/licenses/mit-license.php>)

jQuery.scrollFollow

Website:

<http://kitchen.net-perspective.com/>

License:

Copyright (c) 2008 Net Perspective

Licensed under the MIT License (<http://www.opensource.org/licenses/mit-license.php>)

Flex SDK

Website:

<http://opensource.adobe.com/wiki/display/flexsdk/Flex+SDK>

License:

Copyright (c) 2010 Adobe Systems Incorporated

The contents of this file are subject to the Mozilla Public License Version 1.1 (the "License"); you may not use this file except in compliance with the License. You may obtain a copy of the License at

<http://www.mozilla.org/MPL/>

Software distributed under the License is distributed on an "AS IS" basis, WITHOUT WARRANTY OF ANY KIND, either express or implied. See the License for the specific language governing rights and limitations under the License.

EtherNet/IP Communication Stack

Website:

[sourceforge.net/projects/opener](https://sourceforge.net/projects/opener)

License:

SOFTWARE DISTRIBUTION LICENSE FOR THE  
ETHERNET/IP(TM) COMMUNICATION STACK (ADAPTED BSD STYLE LICENSE)

Copyright (c) 2009, Rockwell Automation, Inc. ALL RIGHTS RESERVED.

EtherNet/IP is a trademark of ODVA, Inc.

# Support

For assistance regarding a component or product, please contact LMI Technologies.

## World

---

Email	<a href="mailto:support@lmi3d.com">support@lmi3d.com</a>
Web	<a href="http://www.lmi3d.com">http://www.lmi3d.com</a>

---

## North America

---

Phone	+1 604 636 1011
Fax	+1 604 516 8368

---

## Europe

---

Phone	+31 45 850 7000
Fax	+31 45 574 2500

---

For more information on safety and laser classifications, please contact:

*U.S. Food and Drug Administration  
Center for Devices and Radiological Health  
WO66-G609  
10903 New Hampshire Avenue  
Silver Spring, MD 20993-0002  
USA*

# Contact

---

## North America

LMI Technologies Inc.  
1673 Cliveden Avenue  
Delta BC V3M 6V5  
Canada  
Phone: +1 604 636 1011  
Fax: +1 604 516 8368

## Europe

LMI Technologies BV  
Valkenburgerweg 223  
NL-6419AT Heerlen  
The Netherlands  
Phone: +31 45 850 7000  
Fax: +31 45 574 2500